

**WIRING DIAGRAMS**  
**Selected Block**  
1989 Ford Taurus  
For <http://www.mitchell.narod.ru/>  
Copyright © 1997 Mitchell International  
Friday, March 02, 2001 02:13PM

1989 WIRING DIAGRAMS  
Ford Motor Co. Wiring Diagrams

Ford; Taurus  
Mercury; Sable

**COMPONENT LOCATION MENU**

COMPONENT LOCATIONS TABLE

AA

Component	Figure No. (Location)
A/C Clutch Cycling Switch	8 (C-D,29)
A/C/Heater Function Switch	8 (B-C,28)
Alternator	1 (B-D,3)
Alternate Output Control Relay	1 (C-D,3)
Auto A/C (EATC) Module	8 (A-B,28)
Auto Lamp Dual Relay	10 (E,39)
Auto Lamp Time Control Switch	8 (E,31)
Back-Up Light Switch	13 (C,49)
Battery	1 (A,1-2)
Blower Motor	8 (A,31)(C,30)
Check Engine Ind	2 (C,6), 3 (C,10), 4 (E,15), 6 (E,21)
Cigarette Lighter Assembly	10 (C-D,39)
Cornering Lights (Taurus)	1 (A,E,1)
Cruise Control Servo	7 (E,24)
Cruise Control Switch	9 (E,34)
Diagnostic Warning Module	9 (B-C,32)
Digital Clock	10 (D,36)
Distributor	2 (C,7), 3 (C,11), 6 (C,21)
Distributorless Ignition System (DIS) Module	4 (C-D,12-13)
Door Ajar Switches	13 (A-B,48)
Door Courtesy Lights	10 (B,36)
Door Lock Switches	12 (A,44,47)
Door Switches	10 (A,36-37)
Electronic Cluster Switch Assembly	11 (A-B,40)
Elect Control Assembly (ECA)(2.5L)	2 (B-E,4)
Elect Control Assembly (ECA)(3.0L EFI)	3 (B-E,8)
Elect Control Assembly (ECA)(3.0L SHO)	4 (A,12-15)
Elect Control Assembly (ECA)(3.8L)	6 (A,20-23)
Elect Flasher	9 (C,34-35)
Engine Compartment Light	1 (E,2)
Fog Lights	1 (B-D,1)
Fog Light Switch	9 (A,32)
Fuel Injectors	2 (E,6), 3 (E,10), 4 (E,13), 6 (C,21)
Fuse Block	7 (C-D,25-26)
Fus Link (Battery)	1 (A,2)
Fus Link (Alternator)	1 (B-C,2)
Fus Link (Alt Output Control Relay)	1 (C,3)
Fus Link (Ignition Switch)	7 (B,26)
Fus Link (Starter Relay)	1 (A,2-3)

# WIRING DIAGRAMS

## Selected Block (p. 2)

1989 Ford Taurus

For <http://www.mitchell.narod.ru/>

Copyright © 1997 Mitchell International

Friday, March 02, 2001 02:13PM

Glove Compartment Switch & Light	8 (A,28)
Heated Exhaust Gas Oxygen (HEGO) Sensor #1	2 (D,6), 3 (D,10), 4 (E,14), 6 (E,22)
Heated Exhaust Gas Oxygen (HEGO) Sensor #2	4 (E,14), 6 (E,22)
Heated Windshield	8 (D,31)
Heated Windshield Control Module	8 (C,31)
Heated Windshield Switch	8 (B-C,31)
Horns	1 (C,1)
Horn Relay	9 (E,35)
Ignition Coil	2 (B,7), 3 (B,11), 4 (D-E,12), 6 (D,20)
Ignition Switch	7 (A-C,24)
Illumination Dimming Relay	10 (C,39)
Illuminated Entry Timer	10 (B-C,37)
Instrument Cluster (Analog)	11 (A-D,43)
Instrument Cluster (Elect)	11 (A-E,41-42)
Integrated Control Module (ICM) 2.5L	2 (A-B,7)
Integrated Control Module (ICM) 3.0L EFI	3 (A-B,11)
Integrated Control Module (ICM) 3.0L SHO	5 (A,18-19)
Integrated Control Module (ICM) 3.8L	5 (E,16-17)
Interval Governor	9 (D,32-33)
Keyless Entry Module	12 (B-C,47)
LCD Dimming Relay	10 (D-E,38)
Liftgate Ajar Switch	13 (A,48)
Liftgate Release Relay	13 (E,49)
Liftgate Release Switch	13 (E,49-50)
Light Sensor/Amplifier	8 (D-E,31)
Main Light Switch	10 (D-E,36)
Moon Roof Control Switch	13 (C,48)
Neutral Safety/Back-Up Light Switch	7 (A-B,27)
Power Antenna Switch	13 (D,48)
Power Mirror Switch	12 (E,46-47)
Power Seat Control Switch	12 (D,44-46)
Power Window Safety Relay	12 (A-B,44)
Radio	10 (C-D,36)
Rear Courtesy Lights	10 (A-B,38)
Rear Window Defogger Control	9 (C-D,34)
Self Test Input (STI) Conn	2 (E,6), 3 (E,10), 4 (E,15), 6 (E,23)
Self Test Output (STO) Conn	2 (C,6), 3 (C,11), 4 (E,14-15), 6 (E,21-22)
Speed Sensor	2 (B,4), 3 (A,8), 6 (A,20)
Spout Conn	2 (B,6), 3 (B,10), 4 (B,12), 6 (C,20)
Starter Relay	1 (A,2)
Stop Light Switch	9 (C,35)
TFI Module	2 (C,7), 3 (C,11), 6 (C-D,21)
Top Gear Switch (M/T)	2 (E,5)
Upshift Dimmer Relay (M/T)	7 (E,25-26)
Voltage Regulator	1 (C,1)(D,2)
Warning Chime Module	6 (E,20), 8 (E,28)
Washer Fluid Level Switch	1 (E,2)
Wiper Motor (Front)	11 (E,3)

# WIRING DIAGRAMS

## Selected Block (p. 3)

1989 Ford Taurus

For <http://www.mitchell.narod.ru/>

Copyright © 1997 Mitchell International

Friday, March 02, 2001 02:13PM

Wiper/Washer Switch (Front)	.....	9 (E,32-33)
Wiper/Washer Switch (Rear)	.....	13 (E,48)
AA		

### WIRING DIAGRAMS

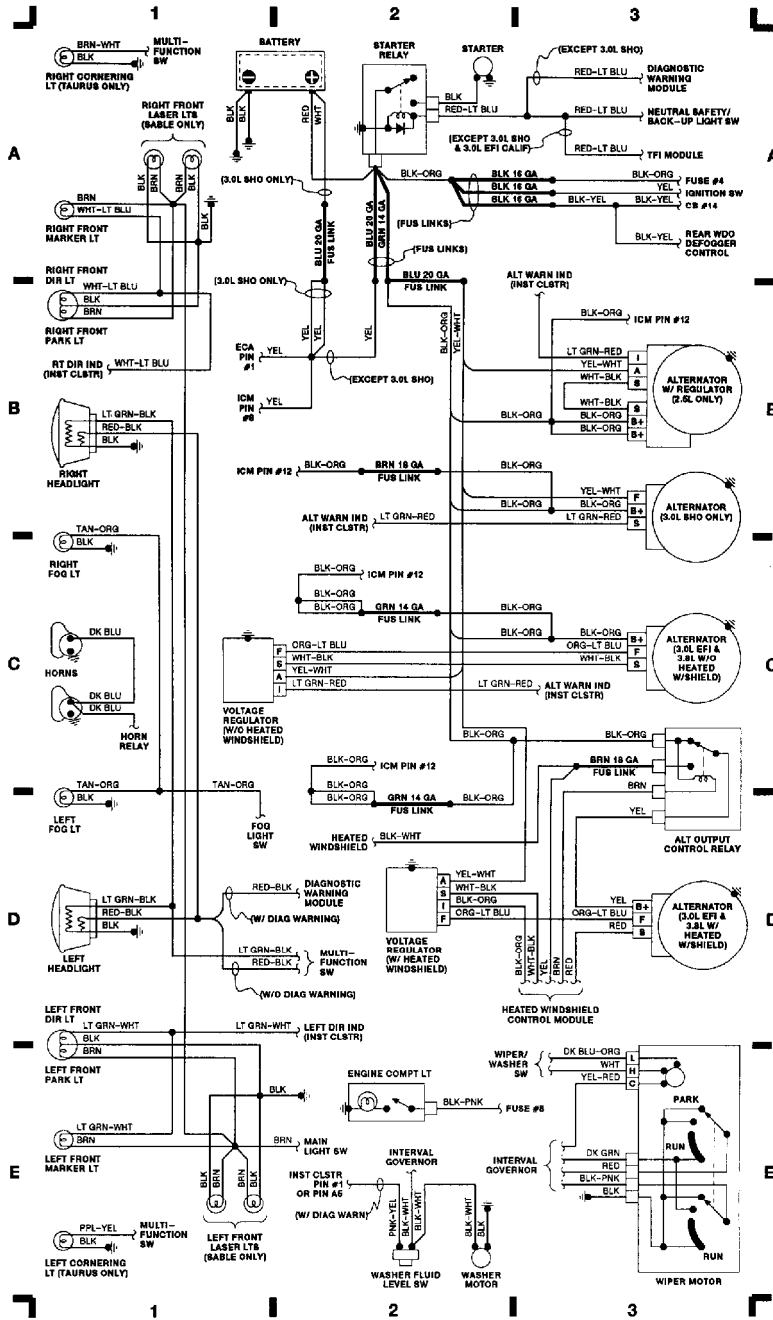

113099

Fig. 1: Engine Compartment & Headlights

# WIRING DIAGRAMS

## Selected Block (p. 4)

1989 Ford Taurus

For <http://www.mitchell.narod.ru/>

Copyright © 1997 Mitchell International

Friday, March 02, 2001 02:13PM

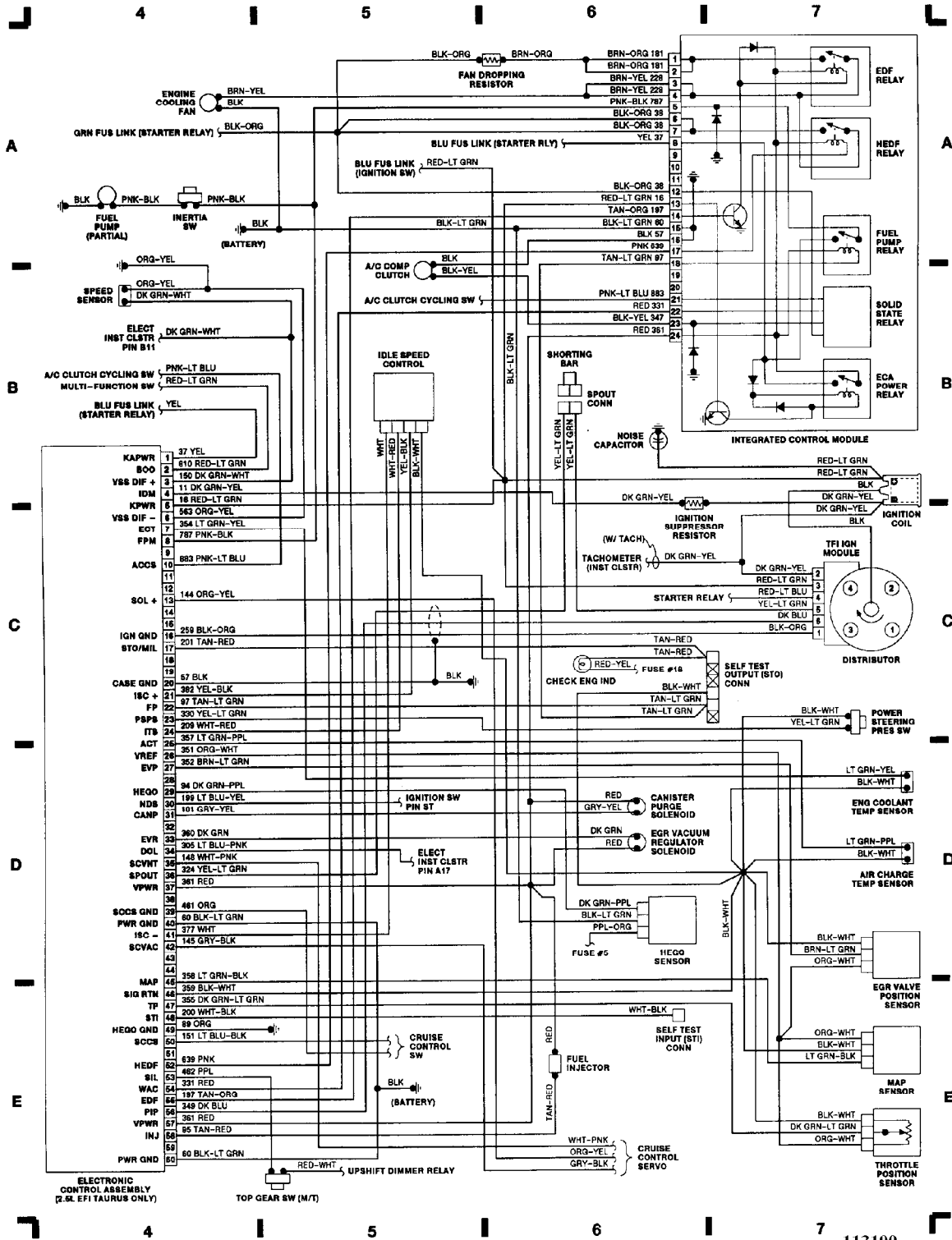

113100

Fig. 2: Computer Engine Control (2.5L)

# WIRING DIAGRAMS

## Selected Block (p. 5)

1989 Ford Taurus

For <http://www.mitchell.narod.ru/>

Copyright © 1997 Mitchell International

Friday, March 02, 2001 02:13PM

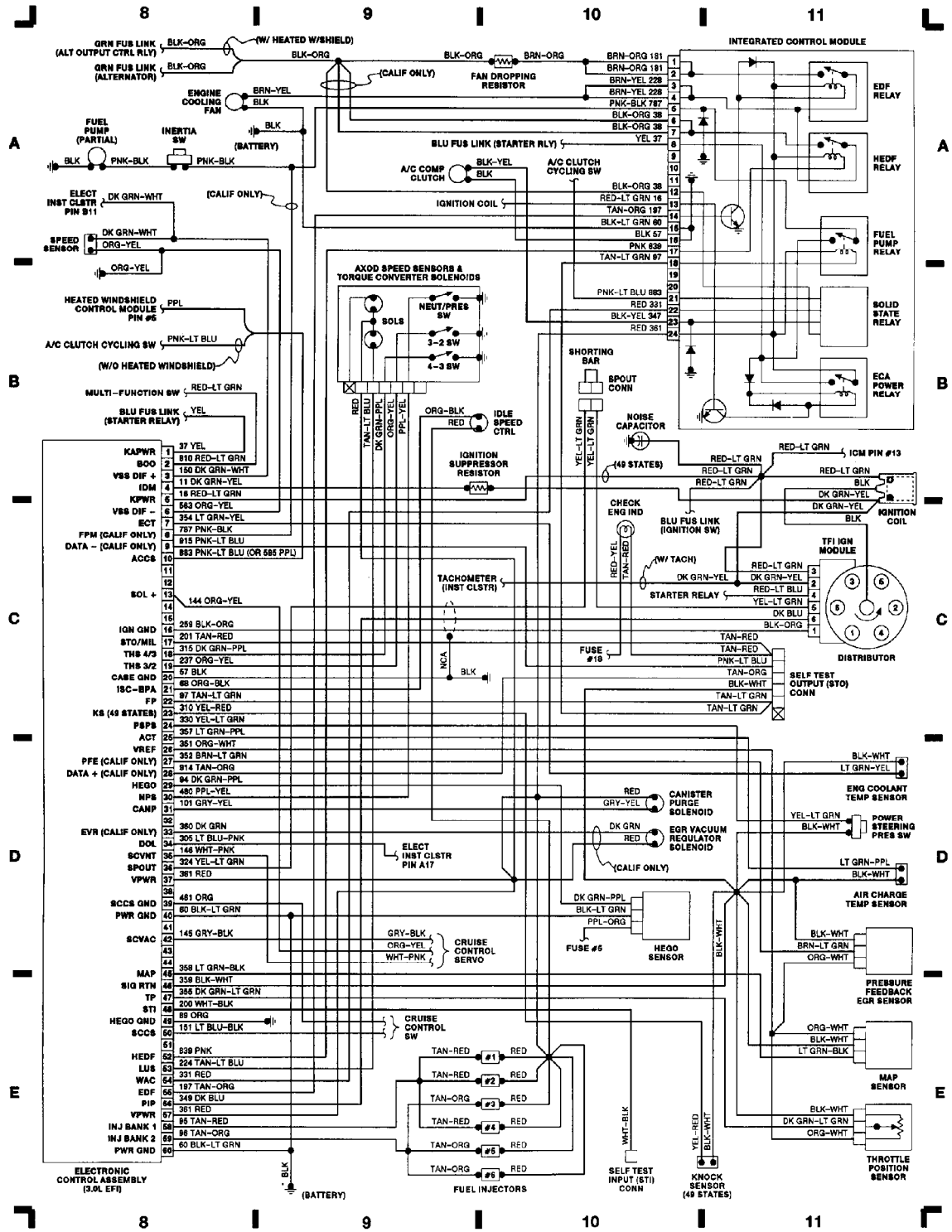

50D01685

Fig. 3: Computer Engine Control (3.0L EFI)

# WIRING DIAGRAMS

## Selected Block (p. 6)

1989 Ford Taurus

For <http://www.mitchell.narod.ru/>

Copyright © 1997 Mitchell International

Friday, March 02, 2001 02:13PM

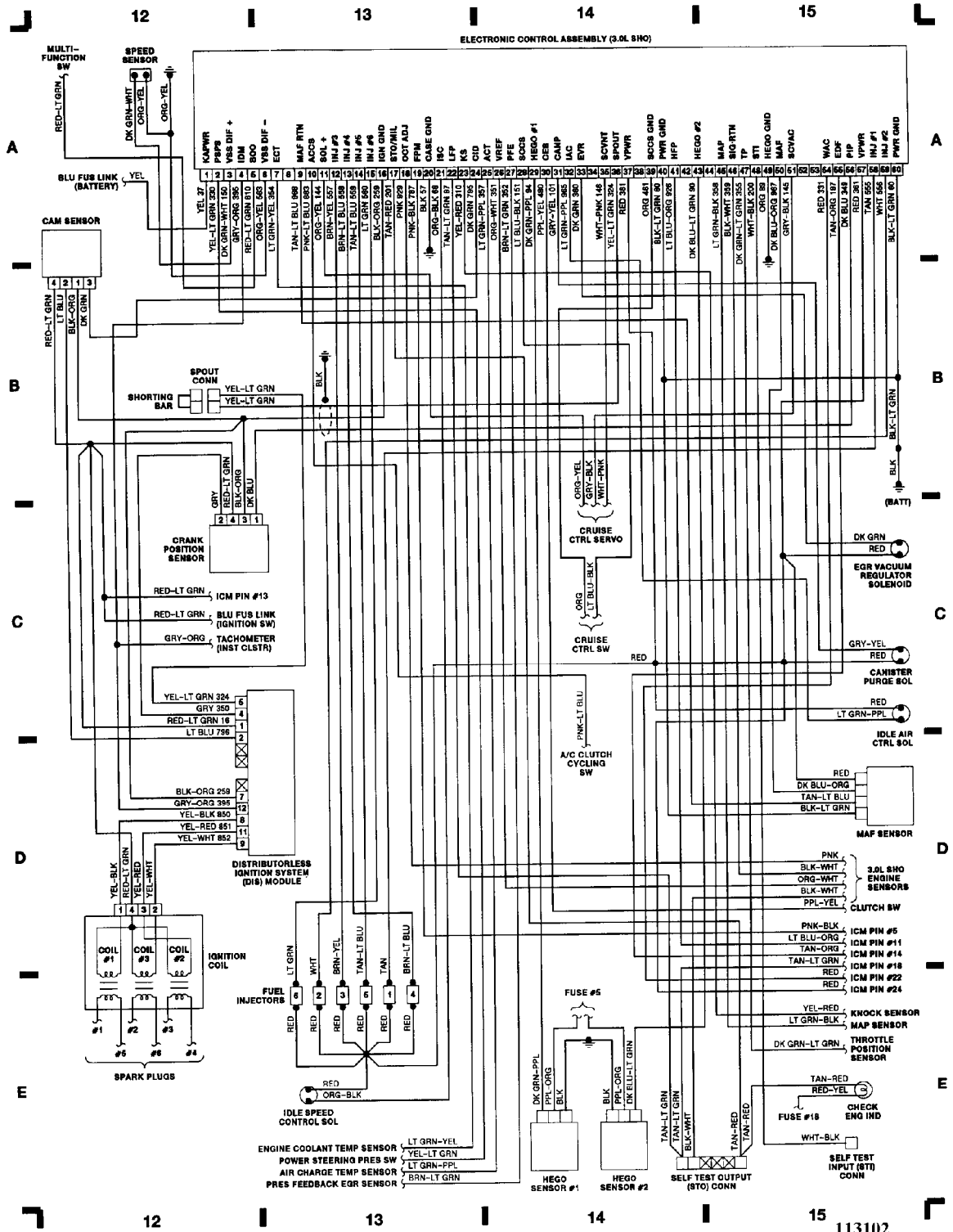

Fig. 4: Computer Engine Control (3.0L SHO)

# WIRING DIAGRAMS

## Selected Block (p. 7)

1989 Ford Taurus

For <http://www.mitchell.narod.ru/>

Copyright © 1997 Mitchell International

Friday, March 02, 2001 02:13PM

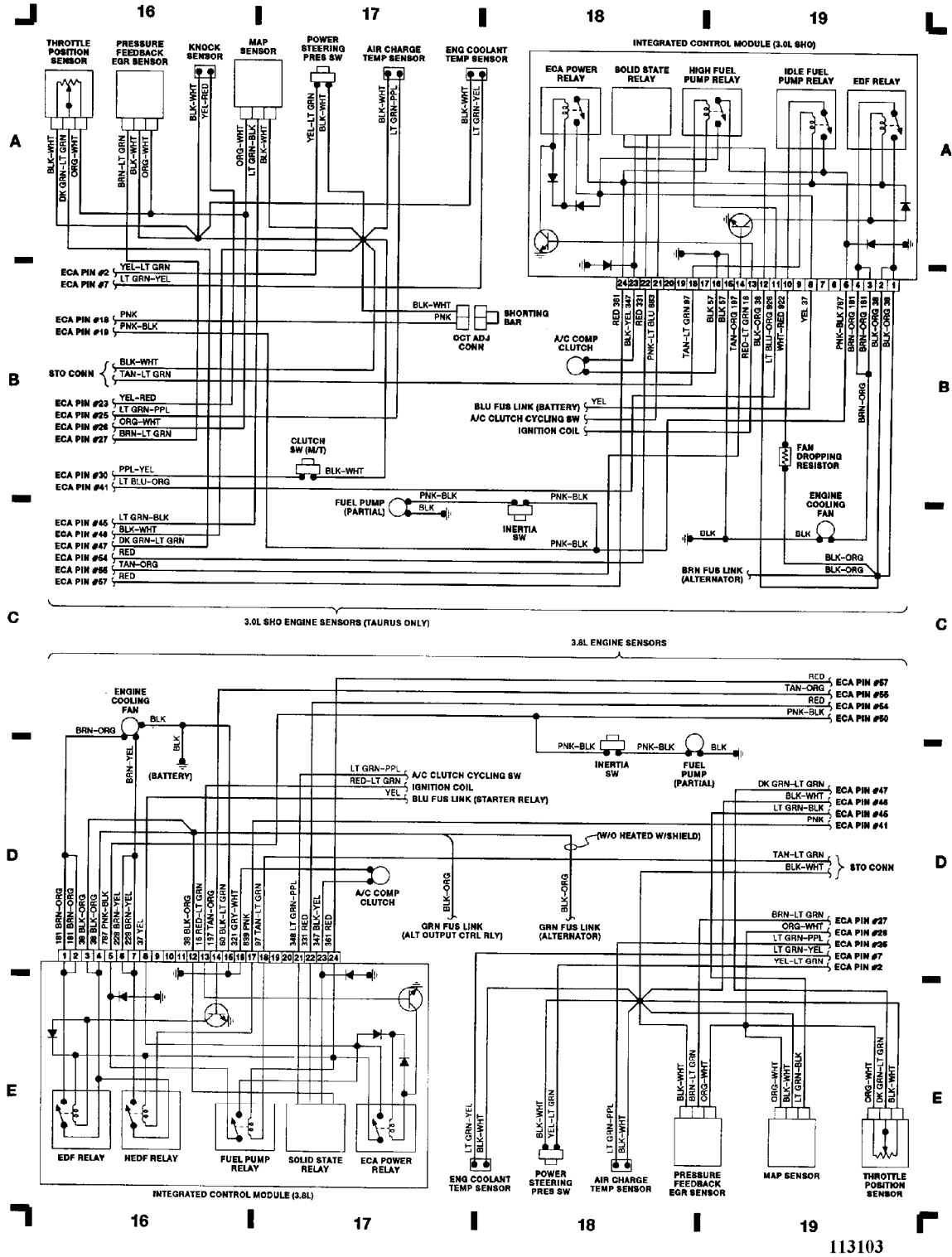

Fig. 5: Engine Control Sensors