

WIRING DIAGRAMS
Selected Block
 1989 Ford Taurus
 For <http://www.mitchell.narod.ru/>
 Copyright © 1997 Mitchell International
 Friday, March 02, 2001 02:13PM

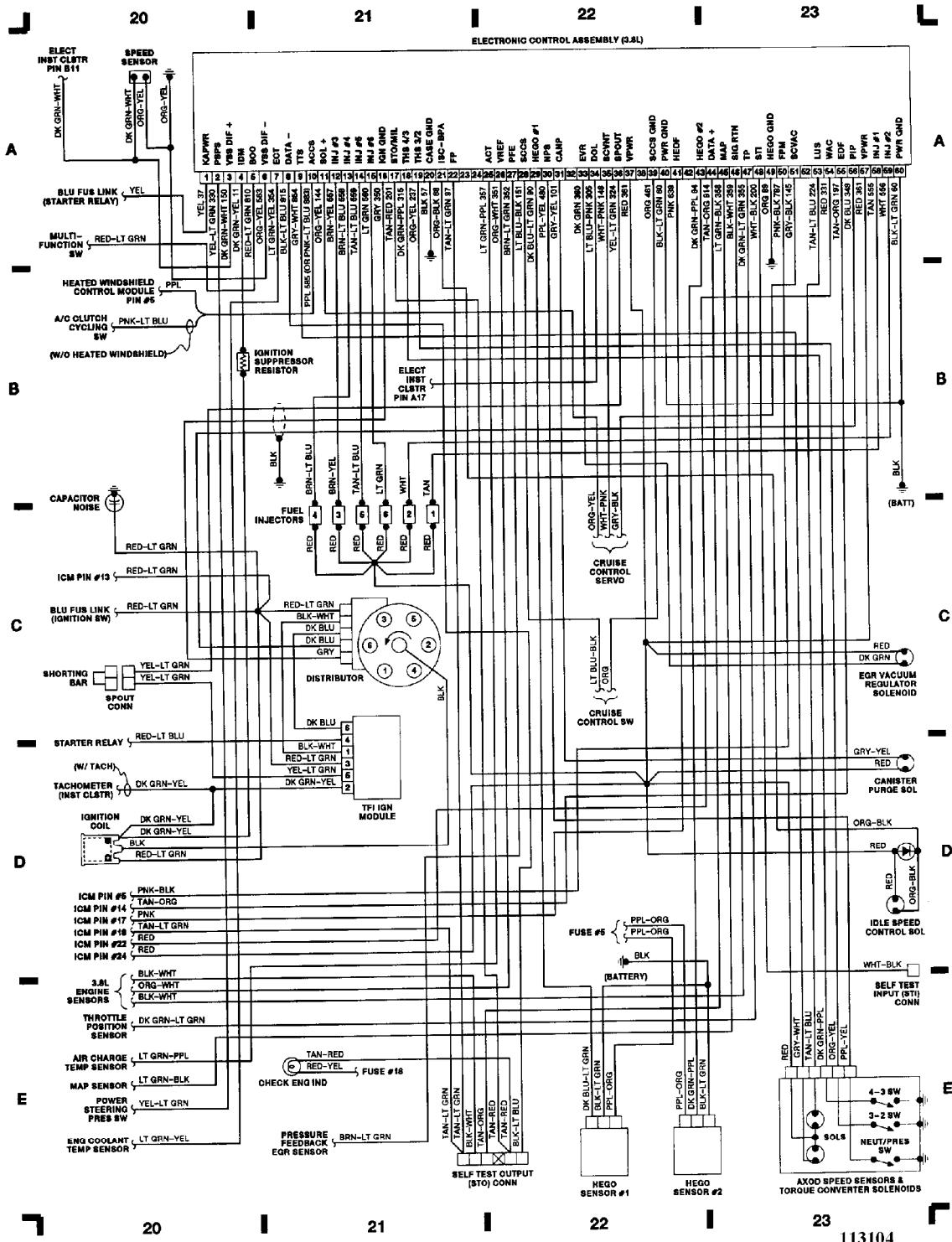

Fig. 6: Computer Engine Control (3.8L)

WIRING DIAGRAMS

Selected Block (p. 2)

1989 Ford Taurus

For <http://www.mitchell.narod.ru/>

Copyright © 1997 Mitchell International

Friday, March 02, 2001 02:13PM

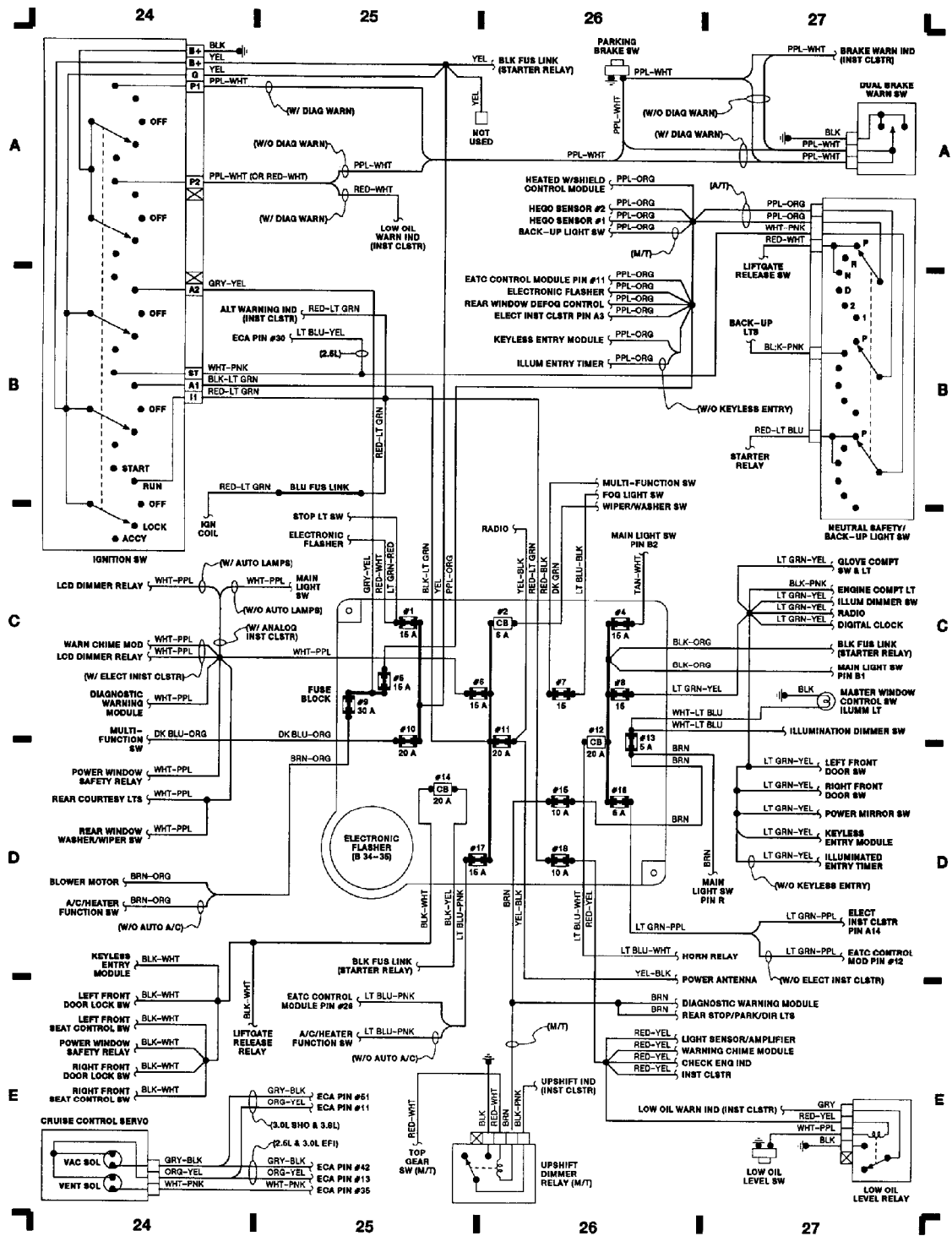

113105

Fig. 7: Fuse Block

WIRING DIAGRAMS

Selected Block (p. 3)

1989 Ford Taurus

For <http://www.mitchell.narod.ru/>

Copyright © 1997 Mitchell International

Friday, March 02, 2001 02:13PM

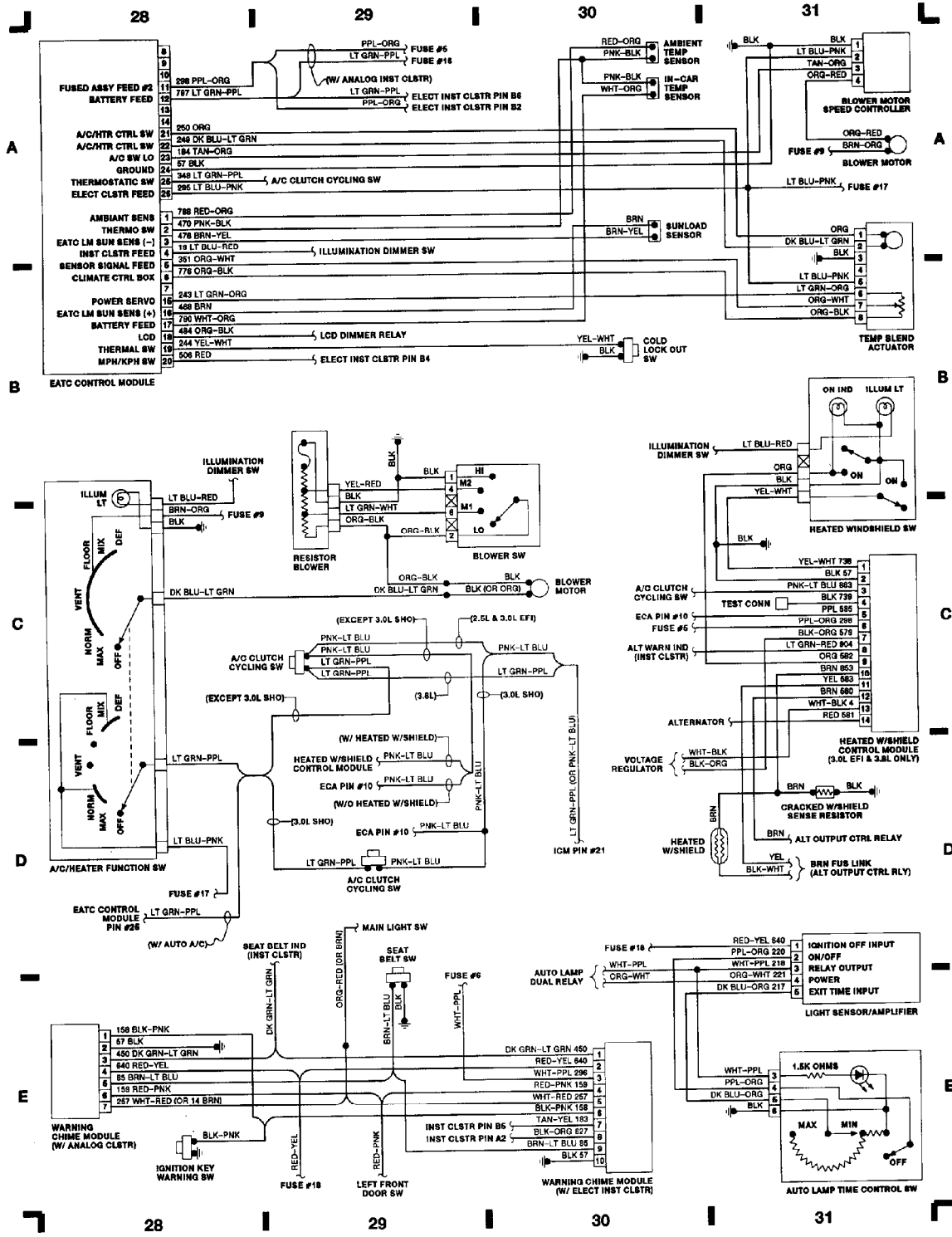

113106

Fig. 8: A/C & Heater

WIRING DIAGRAMS

Selected Block (p. 4)

1989 Ford Taurus

For <http://www.mitchell.narod.ru/>

Copyright © 1997 Mitchell International

Friday, March 02, 2001 02:13PM

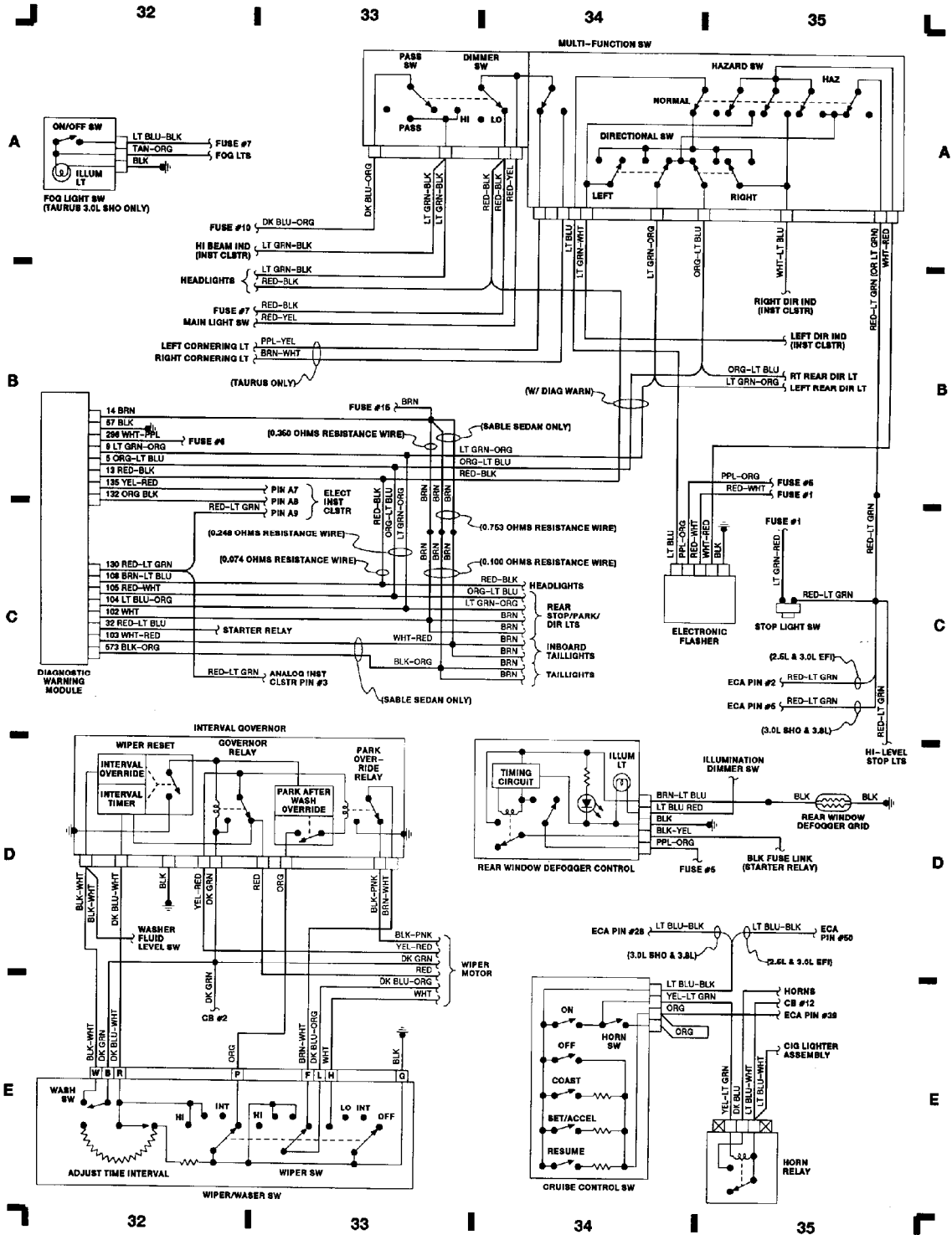

113107

Fig. 9: Multi-Function Switch, Wiper/Washer System & Diagnostic Module

WIRING DIAGRAMS

Selected Block (p. 5)

1989 Ford Taurus

For <http://www.mitchell.narod.ru/>

Copyright © 1997 Mitchell International

Friday, March 02, 2001 02:13PM

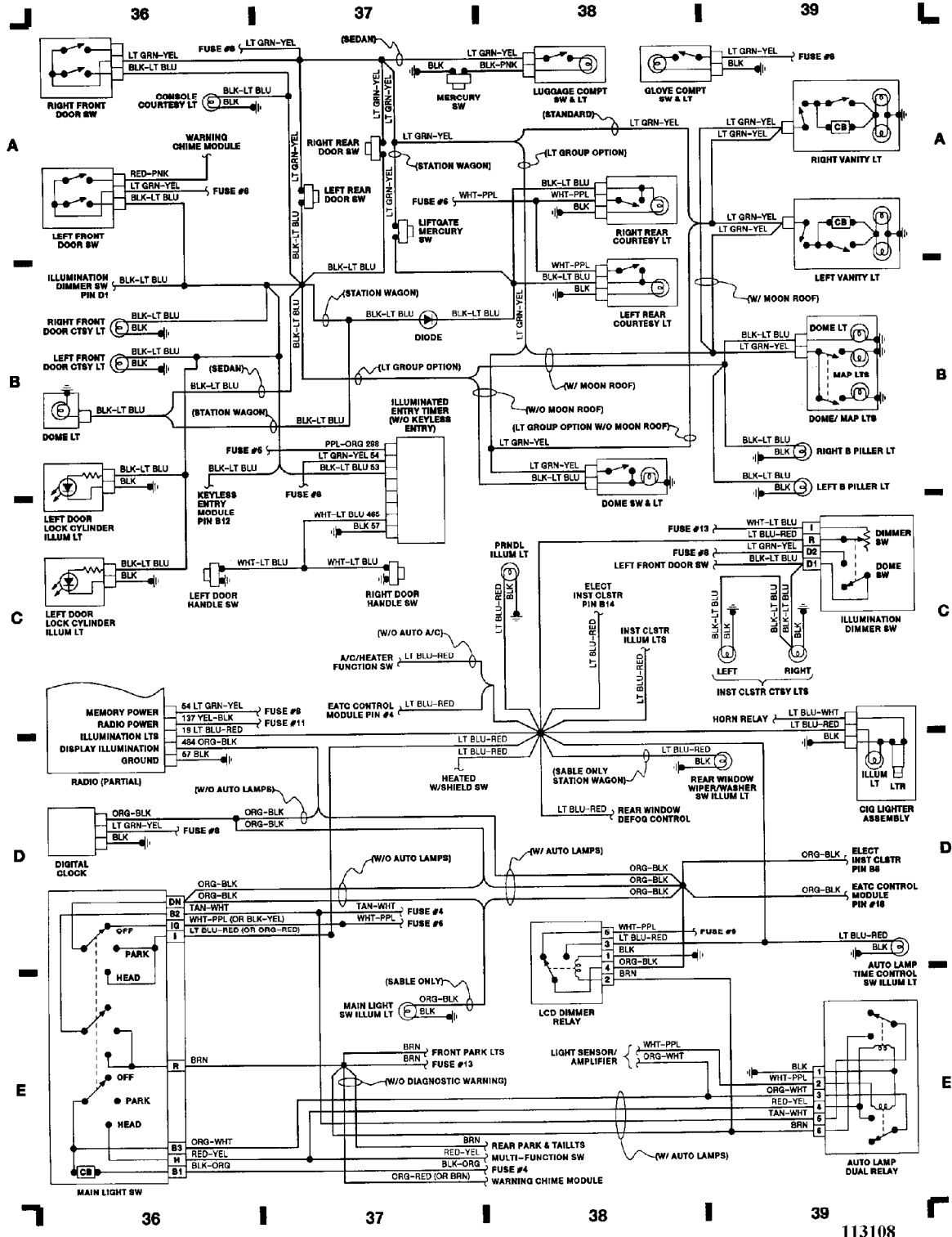

113108

Fig. 10: Accessories

WIRING DIAGRAMS

Selected Block (p. 6)

1989 Ford Taurus

For <http://www.mitchell.narod.ru/>

Copyright © 1997 Mitchell International

Friday, March 02, 2001 02:13PM

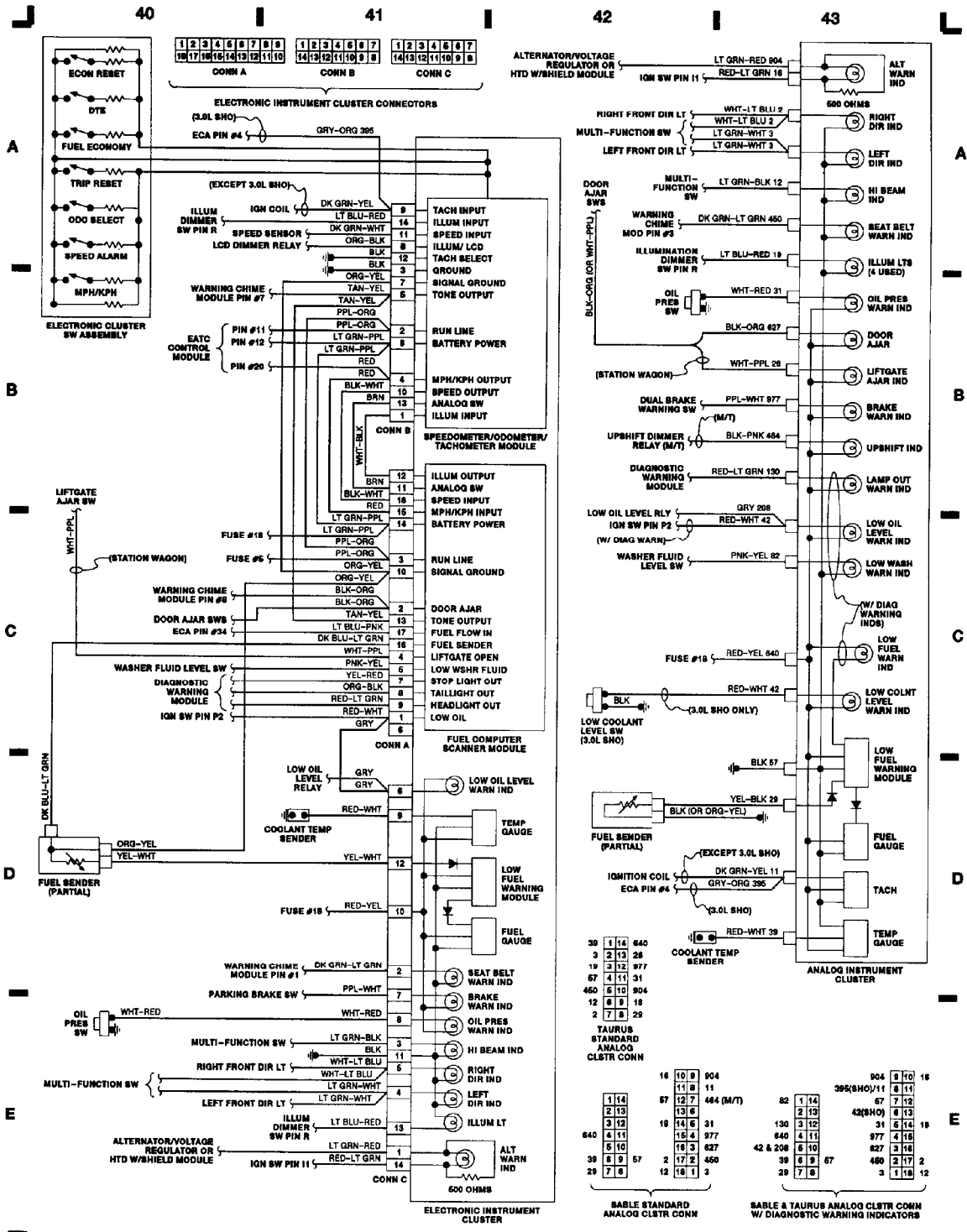

Fig. 11: Instrument Panel

WIRING DIAGRAMS

Selected Block (p. 7)

1989 Ford Taurus

For <http://www.mitchell.narod.ru/>

Copyright © 1997 Mitchell International

Friday, March 02, 2001 02:13PM

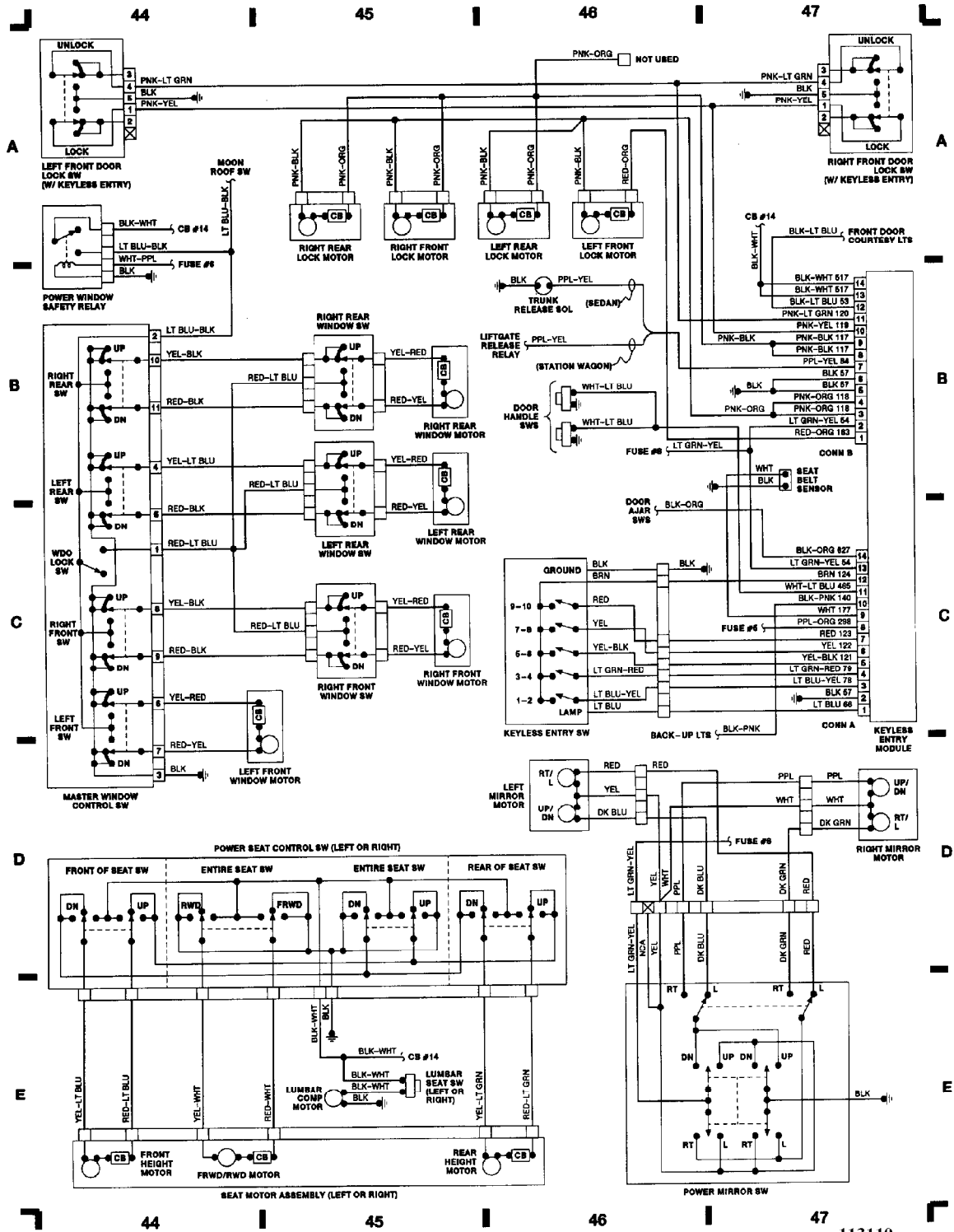

113110

Fig. 12: Passenger Compartment

WIRING DIAGRAMS

Selected Block (p. 8)

1989 Ford Taurus

For <http://www.mitchell.narod.ru/>

Copyright © 1997 Mitchell International

Friday, March 02, 2001 02:13PM

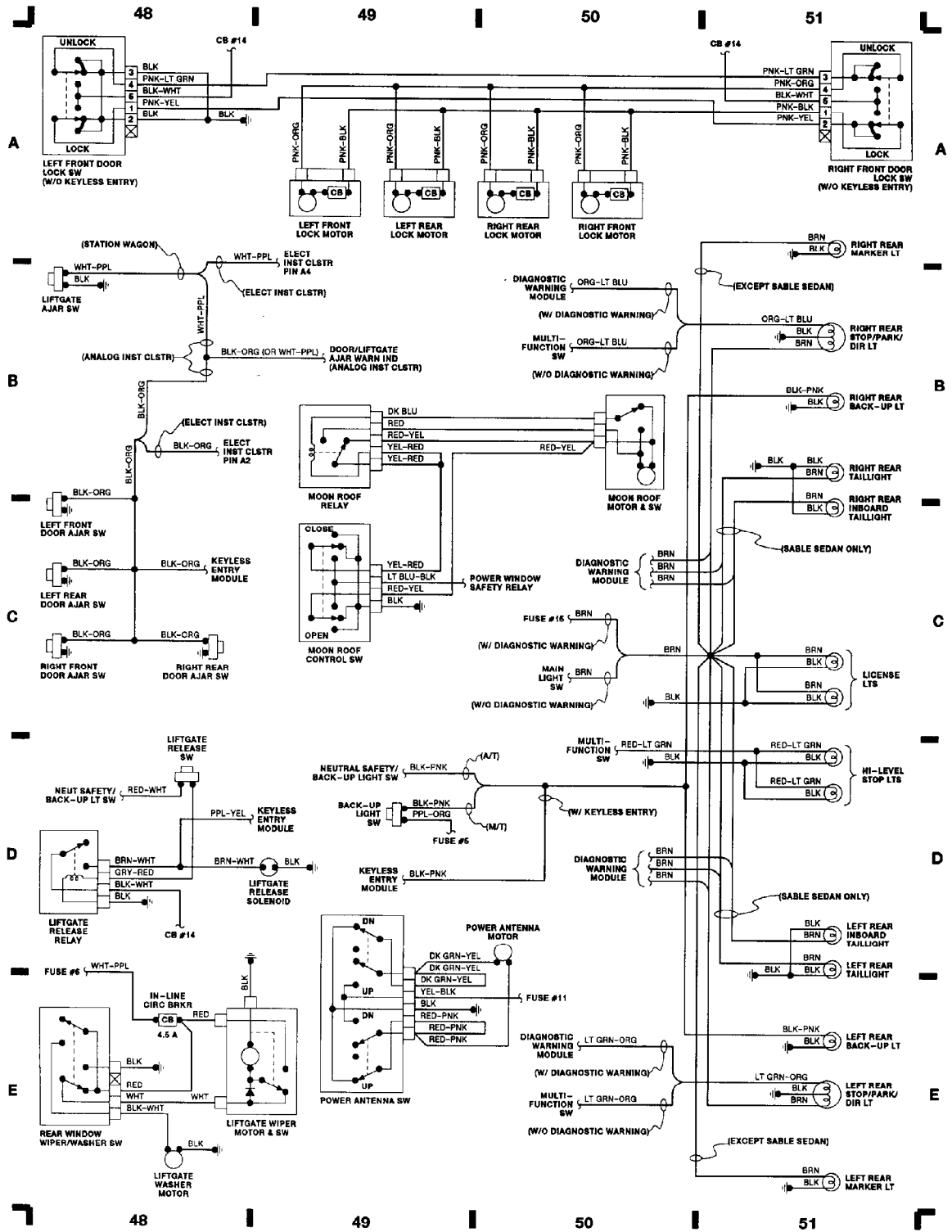

Fig. 13: Passenger Compartment (Cont.) & Taillights