

SUB-CIRCUIT DIAGRAMS

Selected Block

1990 Ford Taurus

For <http://www.mitchell.narod.ru/>

Copyright © 1997 Mitchell International

Friday, March 02, 2001 02:15PM

3.0L MODELS (EXCEPT SHO)

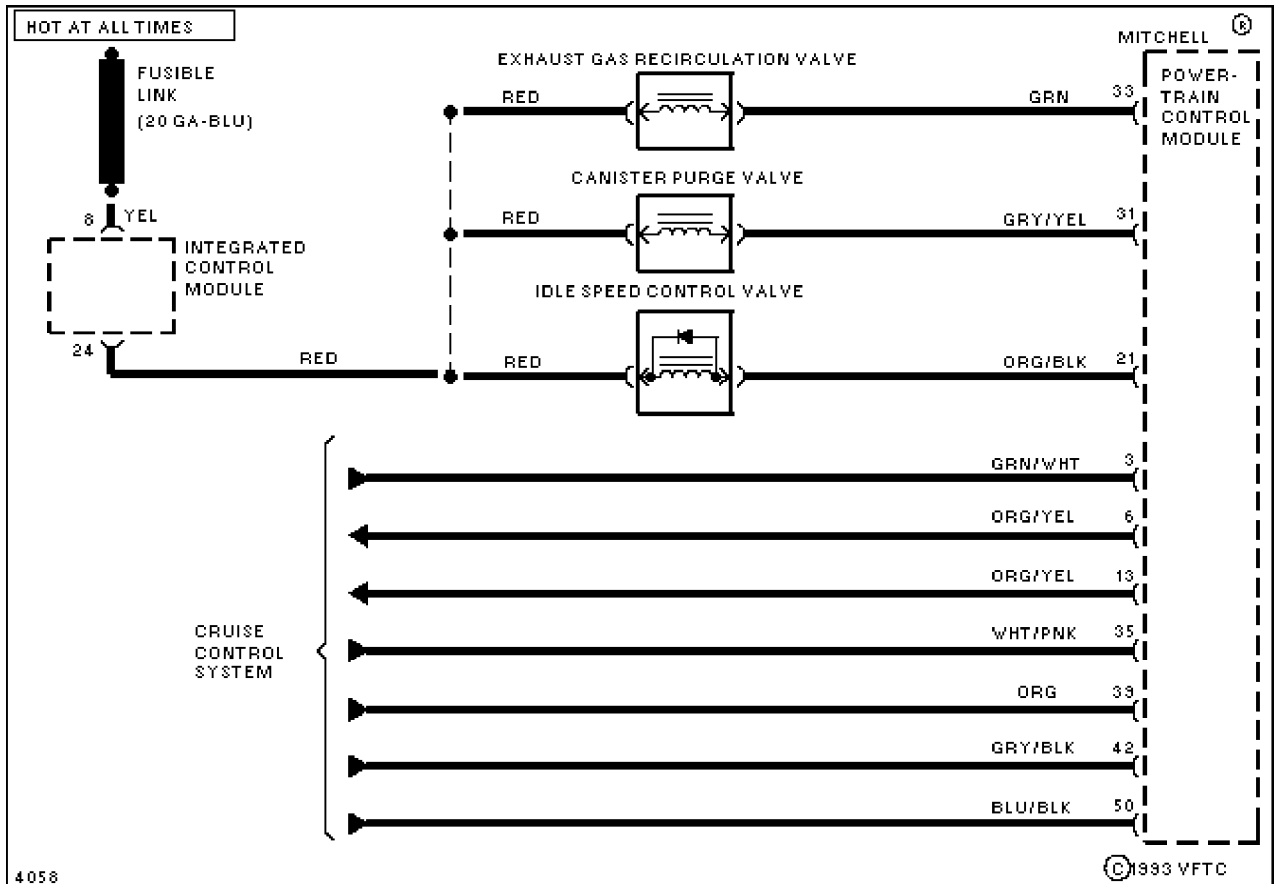

Fig. 30: Cruise & Valve Control Circuit (3.0L)

SUB-CIRCUIT DIAGRAMS

Selected Block (p. 2)

1990 Ford Taurus

For <http://www.mitchell.narod.ru/>

Copyright © 1997 Mitchell International

Friday, March 02, 2001 02:15PM

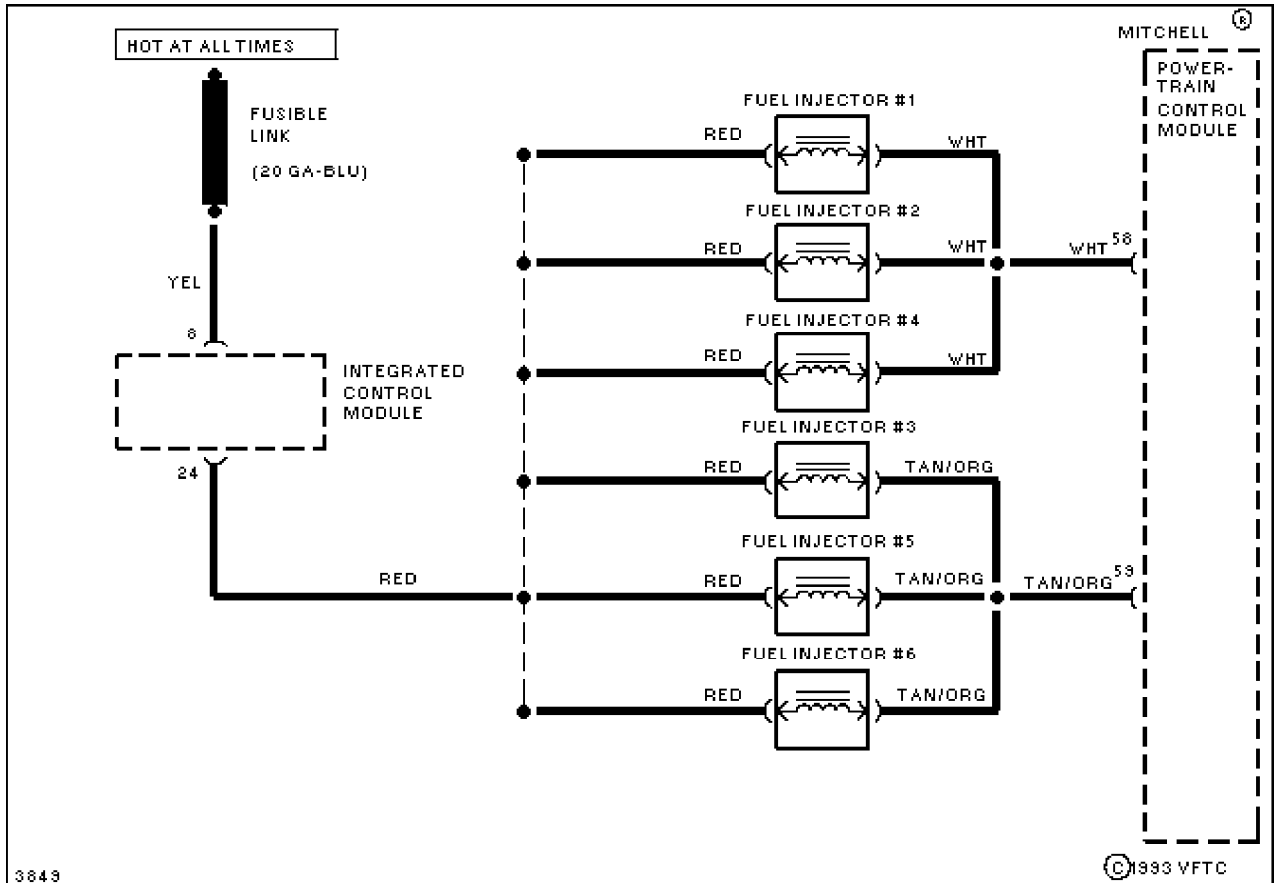

Fig. 31: Fuel Injector Circuit (3.0L)

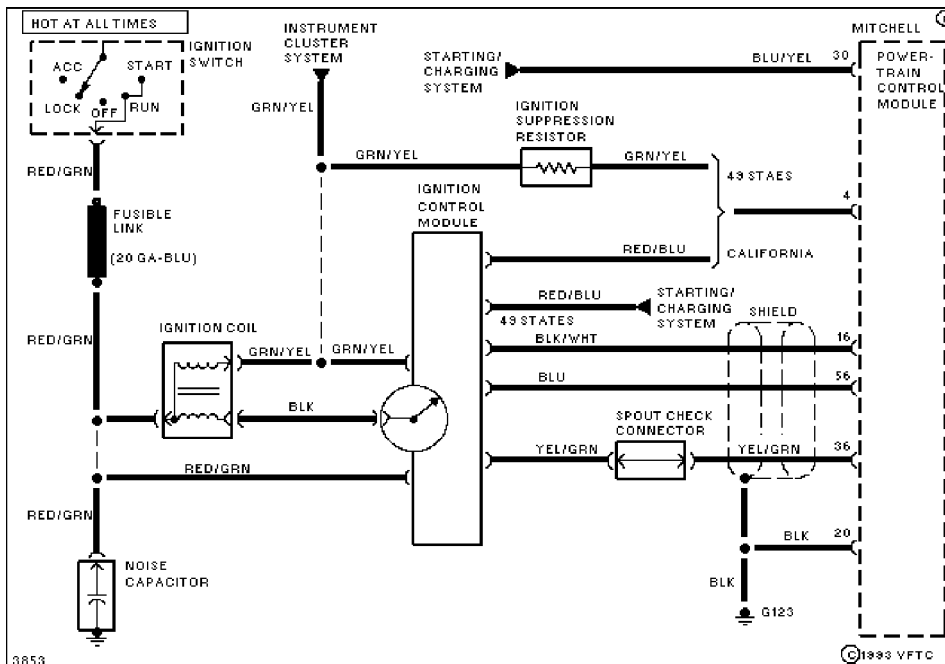

Fig. 32: Ignition Circuit (3.0L)

SUB-CIRCUIT DIAGRAMS

Selected Block (p. 3)

1990 Ford Taurus

For <http://www.mitchell.narod.ru/>

Copyright © 1997 Mitchell International

Friday, March 02, 2001 02:15PM

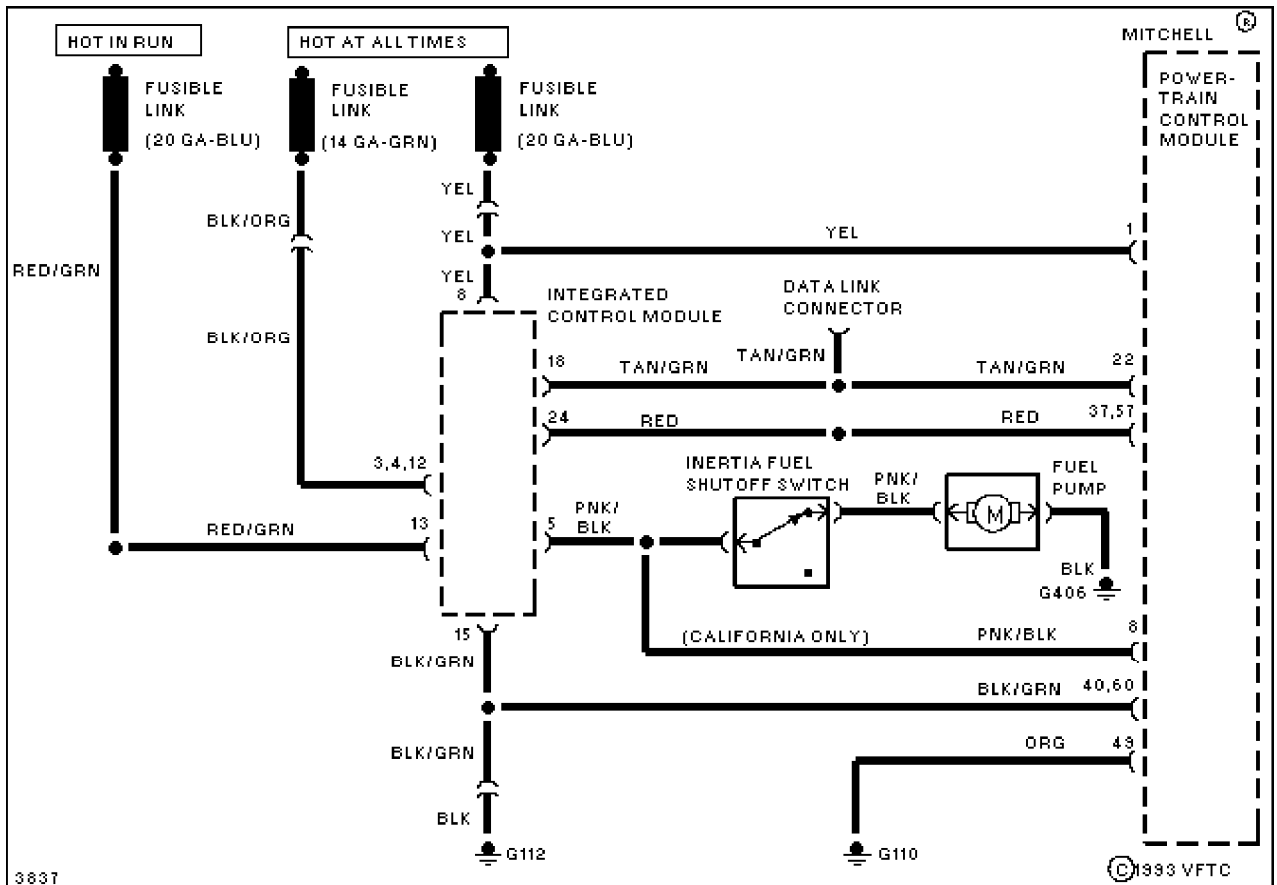

Fig. 33: Power, Ground & Fuel Pump Circuit (3.0L)

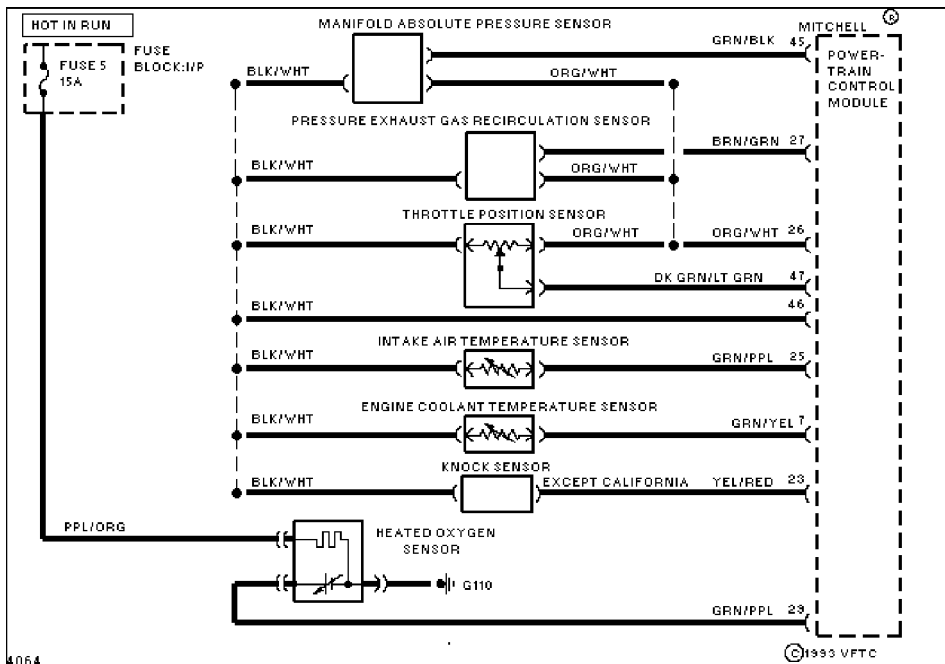

Fig. 34: Sensor & Valve Control Circuit (3.0L)

SUB-CIRCUIT DIAGRAMS

Selected Block (p. 4)

1990 Ford Taurus

For <http://www.mitchell.narod.ru/>

Copyright © 1997 Mitchell International

Friday, March 02, 2001 02:15PM

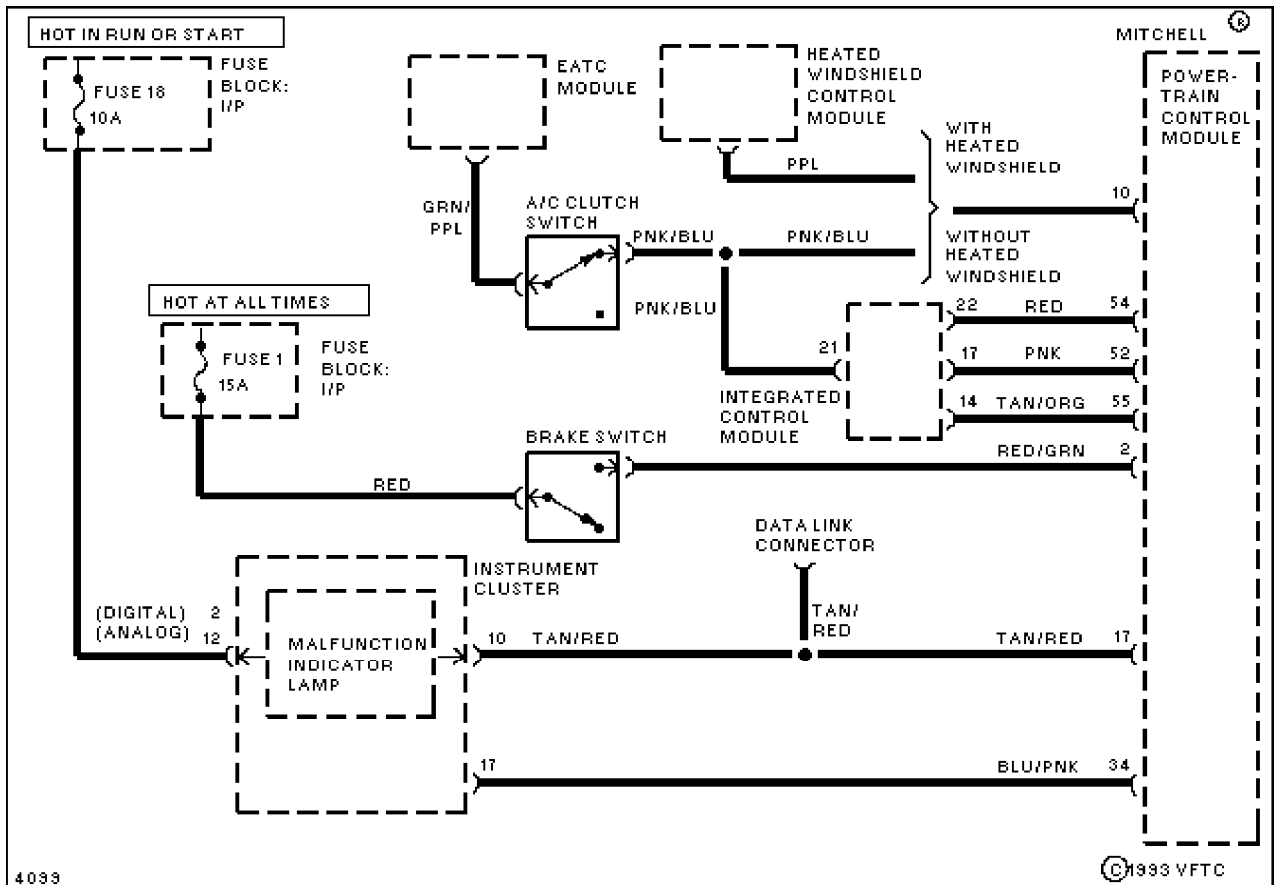

Fig. 35: Warning Indicator & A/C Control (3.0L)