

**SUB-CIRCUIT DIAGRAMS**  
**Selected Block**  
 1990 Ford Taurus  
 For <http://www.mitchell.narod.ru/>  
 Copyright © 1997 Mitchell International  
 Friday, March 02, 2001 02:15PM

**EXTERIOR LIGHTS (EXCEPT HEADLIGHTS)**

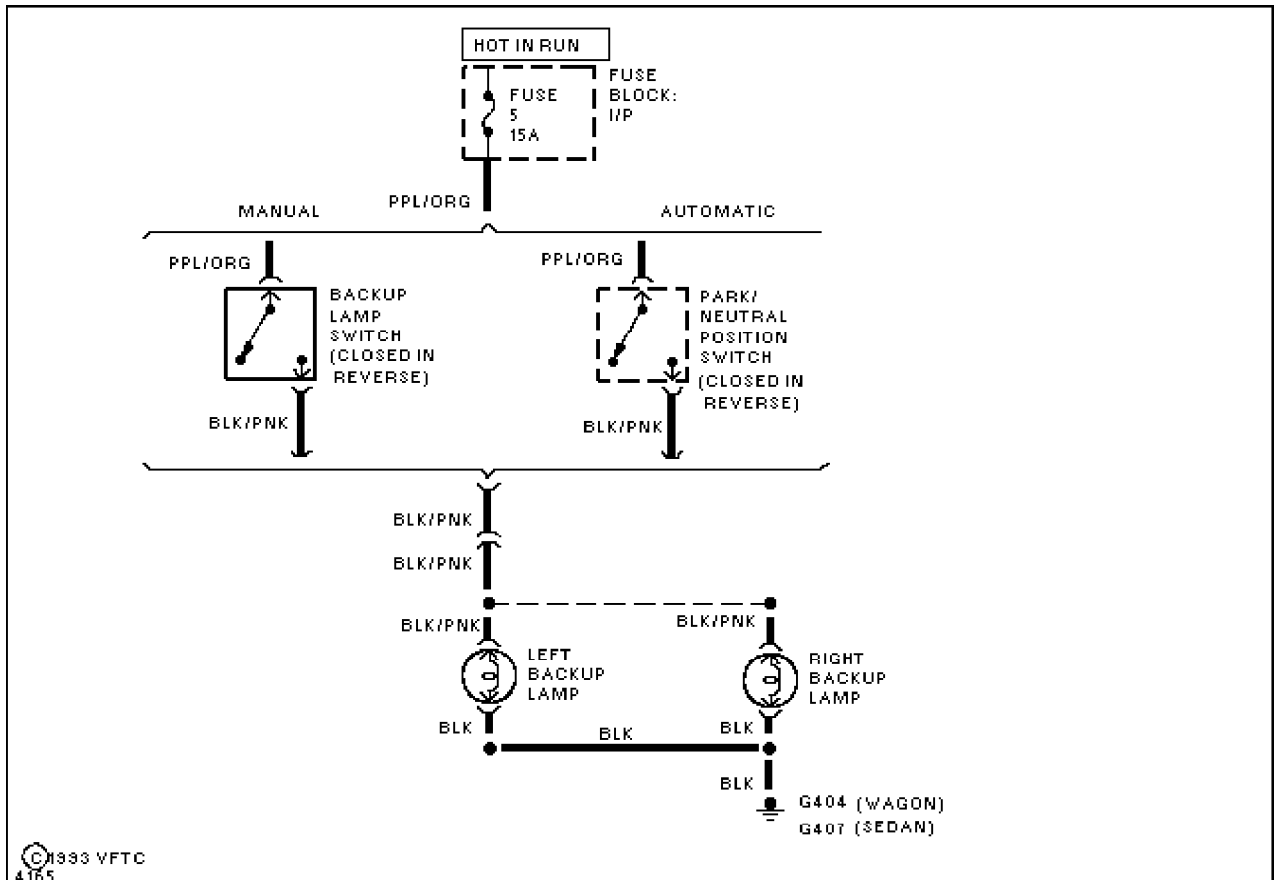

Fig. 47: Backup Lamps

# SUB-CIRCUIT DIAGRAMS

## Selected Block (p. 2)

1990 Ford Taurus

For <http://www.mitchell.narod.ru/>

Copyright © 1997 Mitchell International

Friday, March 02, 2001 02:15PM

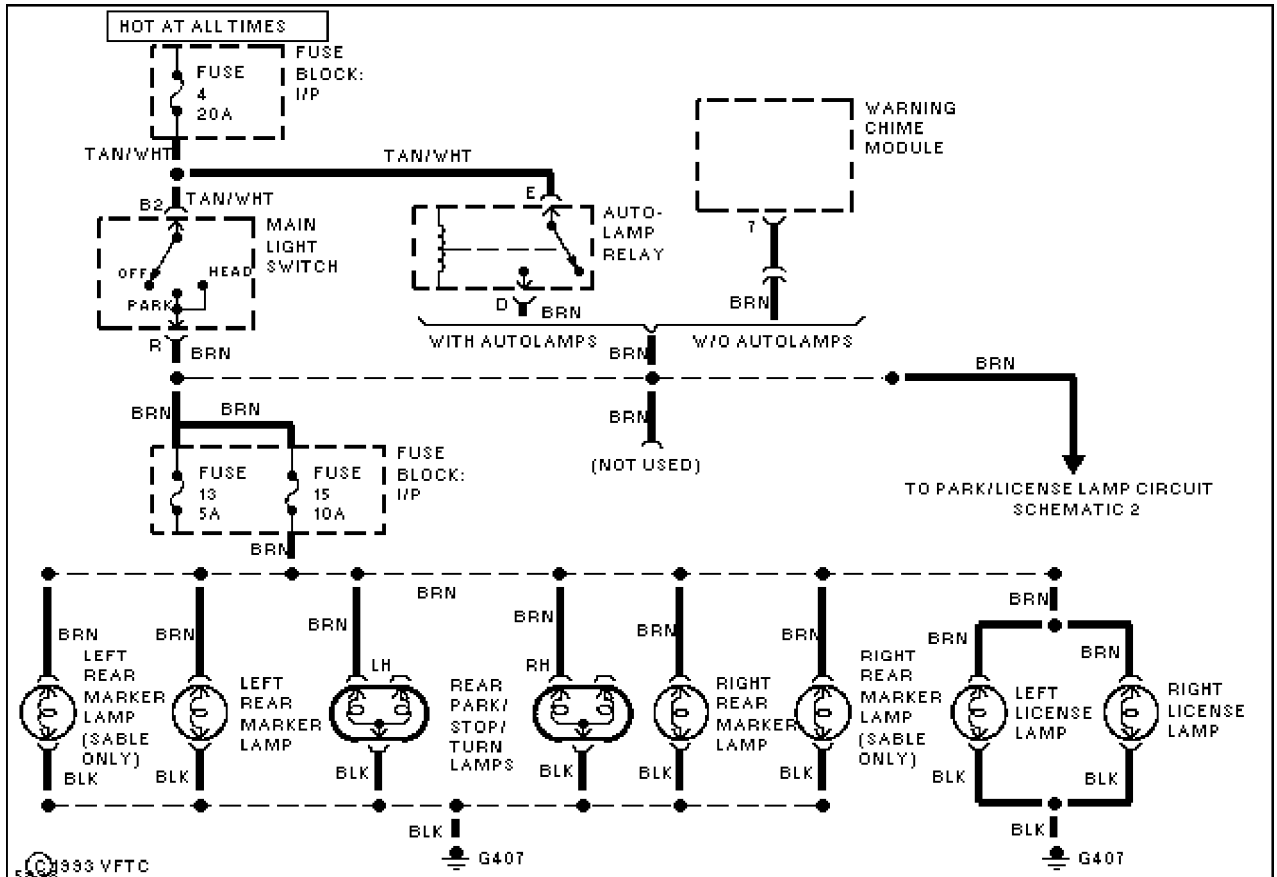

Fig. 48: Park/License Lamps (Sedan W/O Lamp Out Warning) (1 of 2)

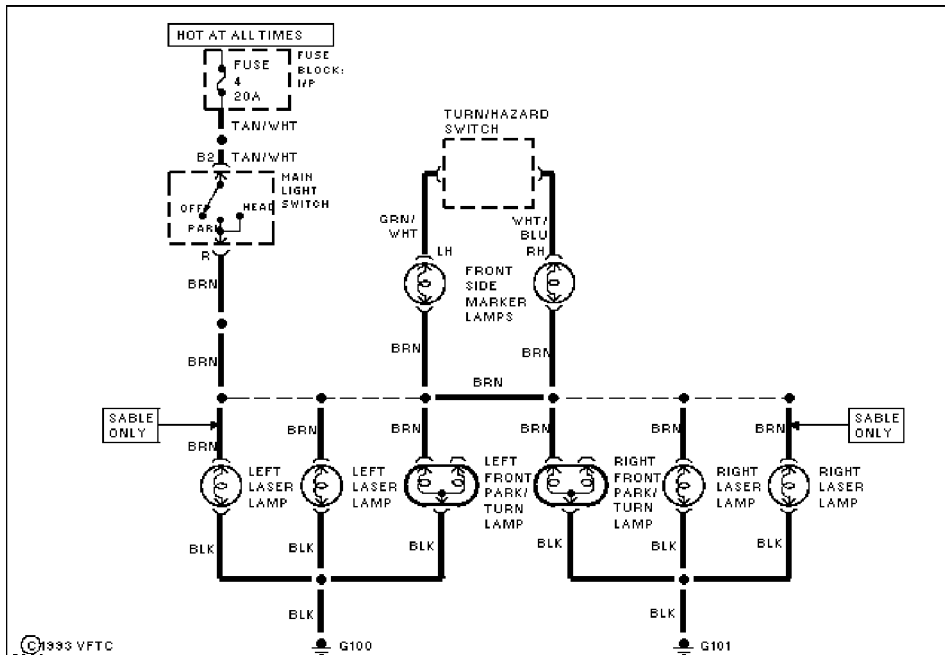

Fig. 49: Park/License Lamps (Sedan W/O Lamp Out Warning) (2 of 2)

# SUB-CIRCUIT DIAGRAMS

## Selected Block (p. 3)

1990 Ford Taurus

For <http://www.mitchell.narod.ru/>

Copyright © 1997 Mitchell International

Friday, March 02, 2001 02:15PM

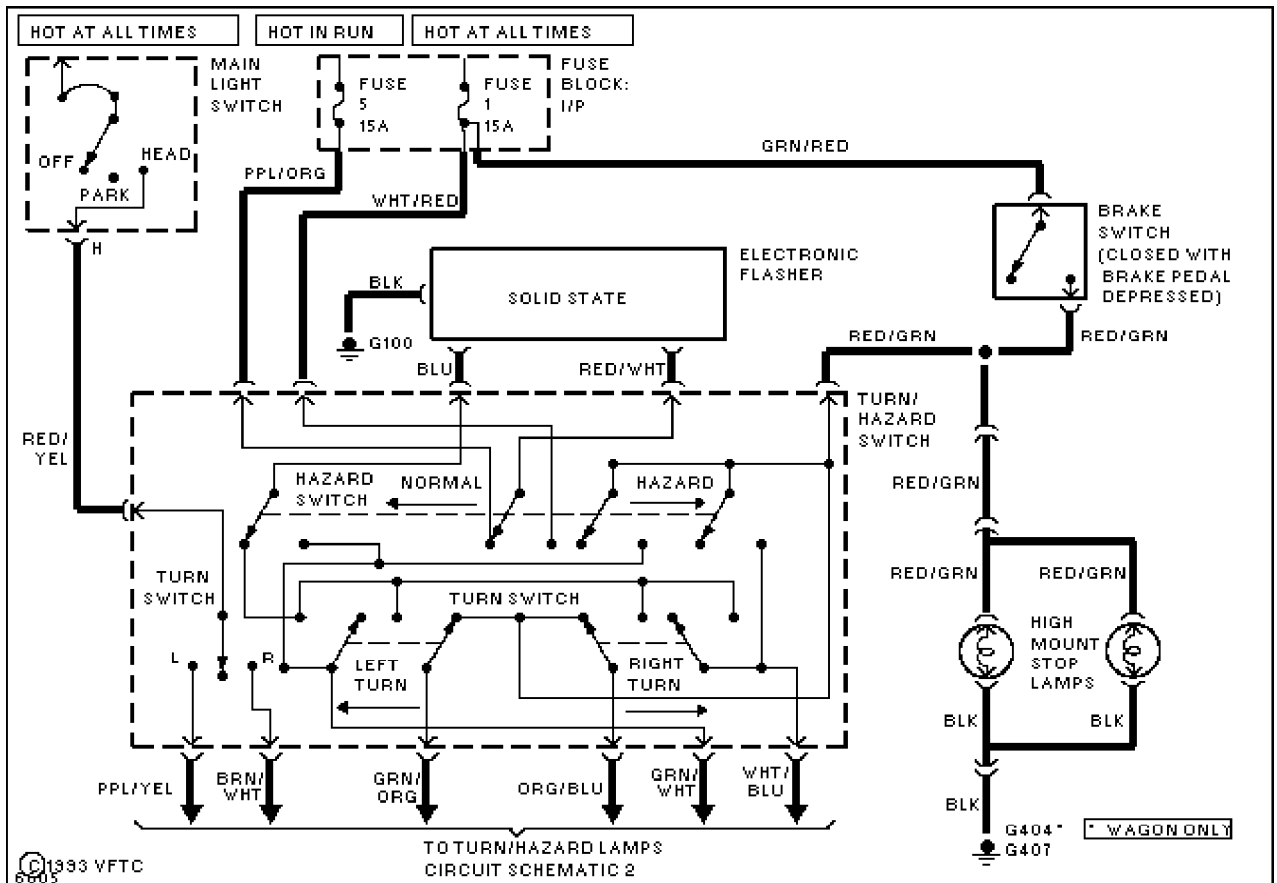

Fig. 50: Turn/Hazard/Stop/Cornering Lamps (1 of 2)

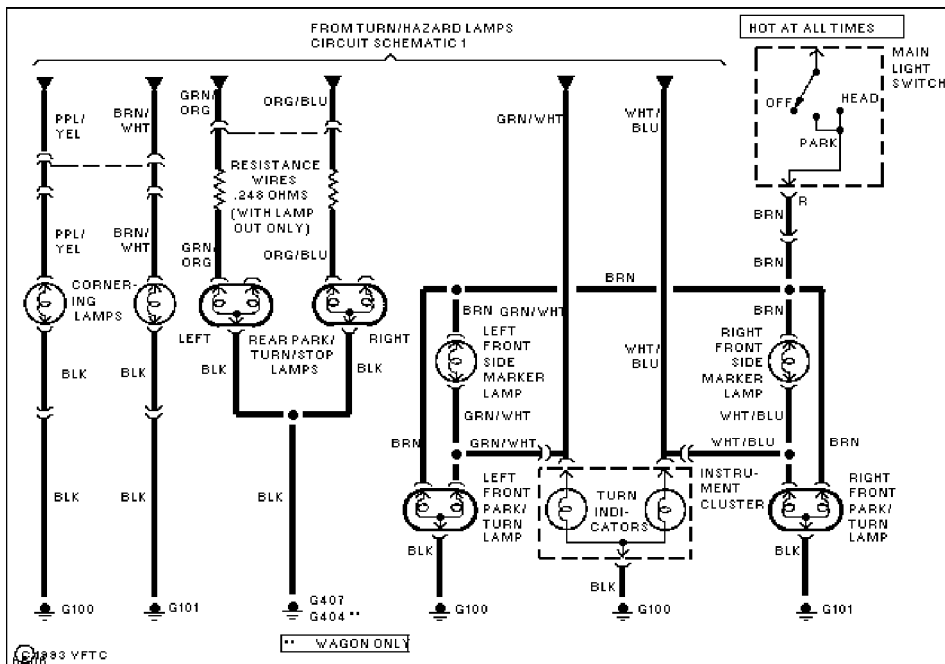

Fig. 51: Turn/Hazard/Stop/Cornering Lamps (1 of 2)

# SUB-CIRCUIT DIAGRAMS

## Selected Block (p. 4)

1990 Ford Taurus

For <http://www.mitchell.narod.ru/>

Copyright © 1997 Mitchell International

Friday, March 02, 2001 02:15PM

### HEADLIGHTS & FOG LIGHTS

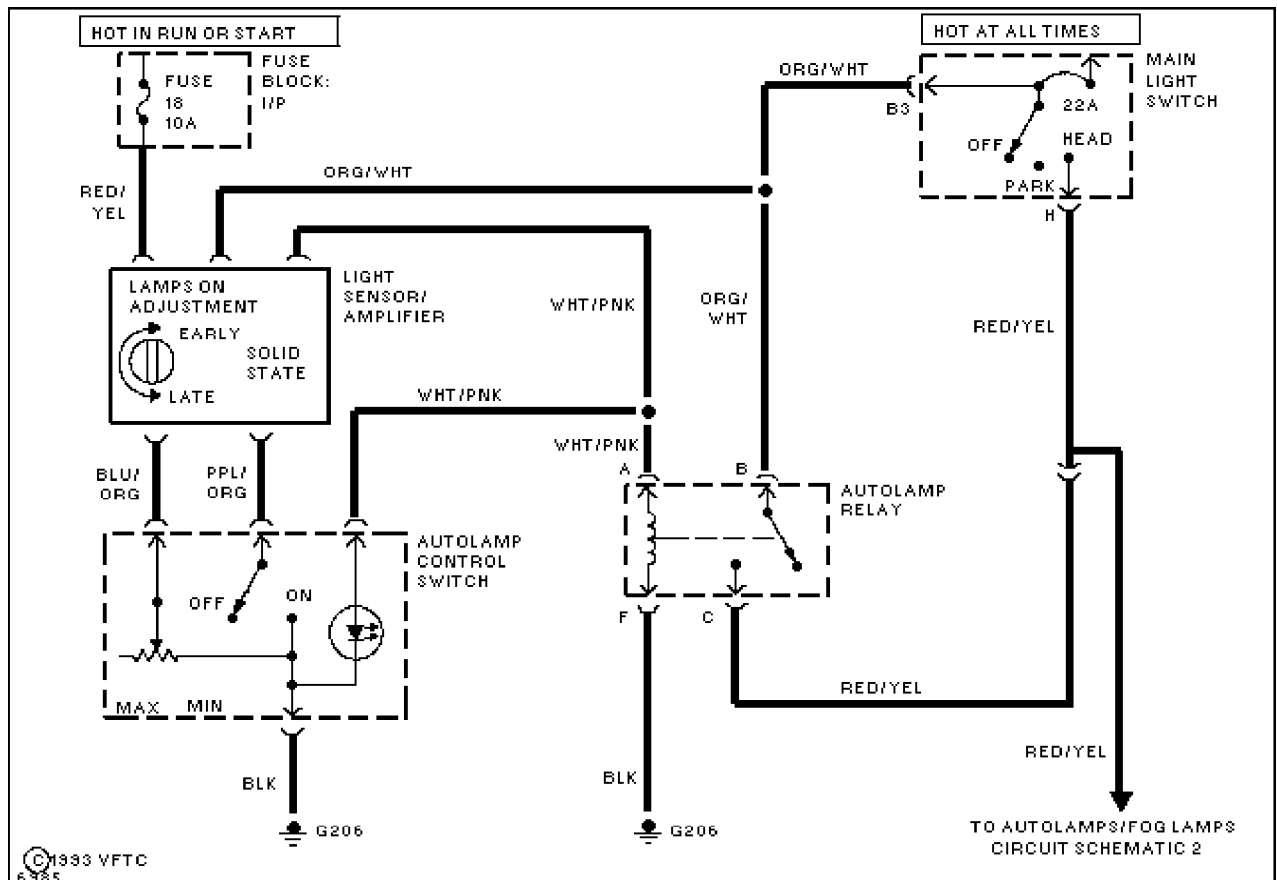

Fig. 52: Autolamps/Fog Lamps (1 of 3)

# SUB-CIRCUIT DIAGRAMS

## Selected Block (p. 5)

1990 Ford Taurus

For <http://www.mitchell.narod.ru/>

Copyright © 1997 Mitchell International

Friday, March 02, 2001 02:15PM

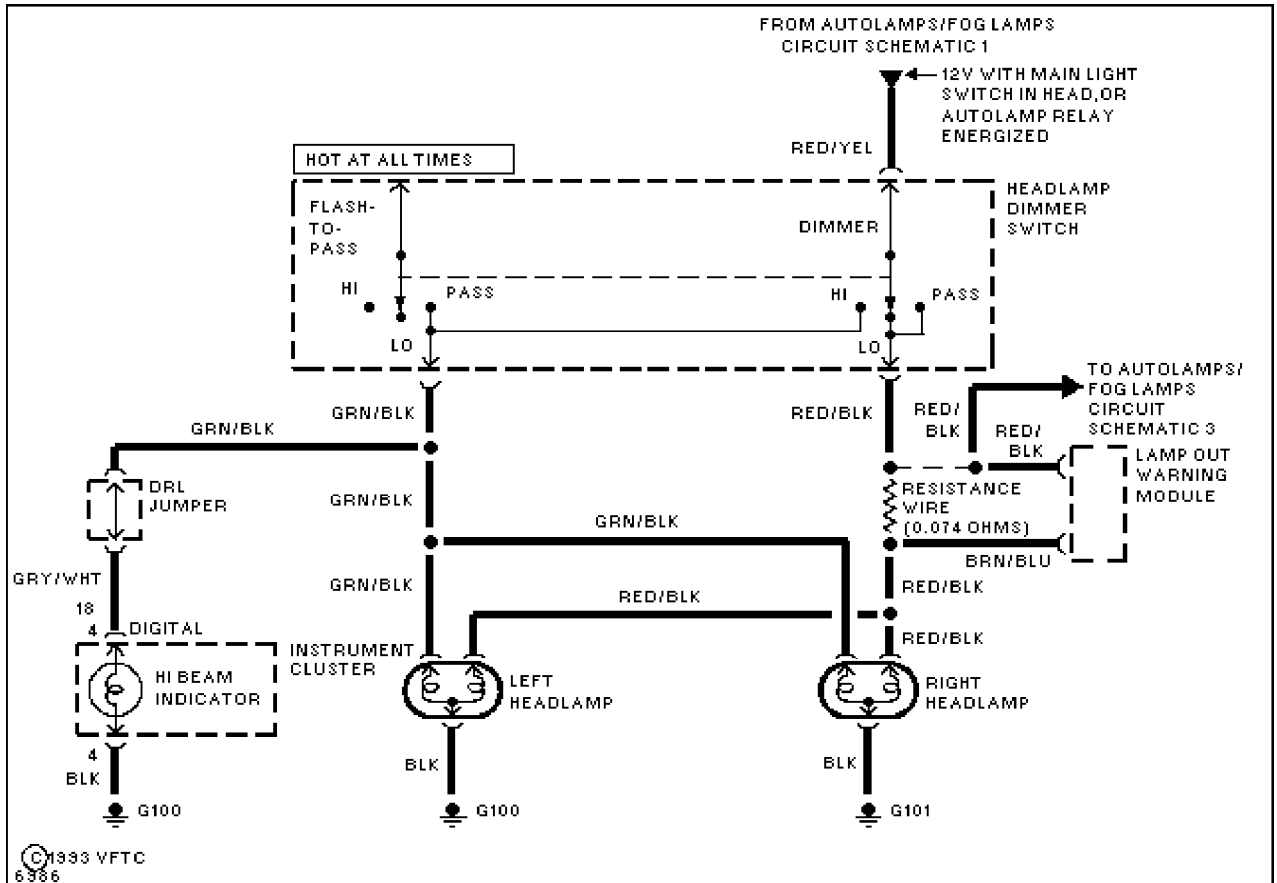

Fig. 53: Autolamps/Fog Lamps (2 of 3)

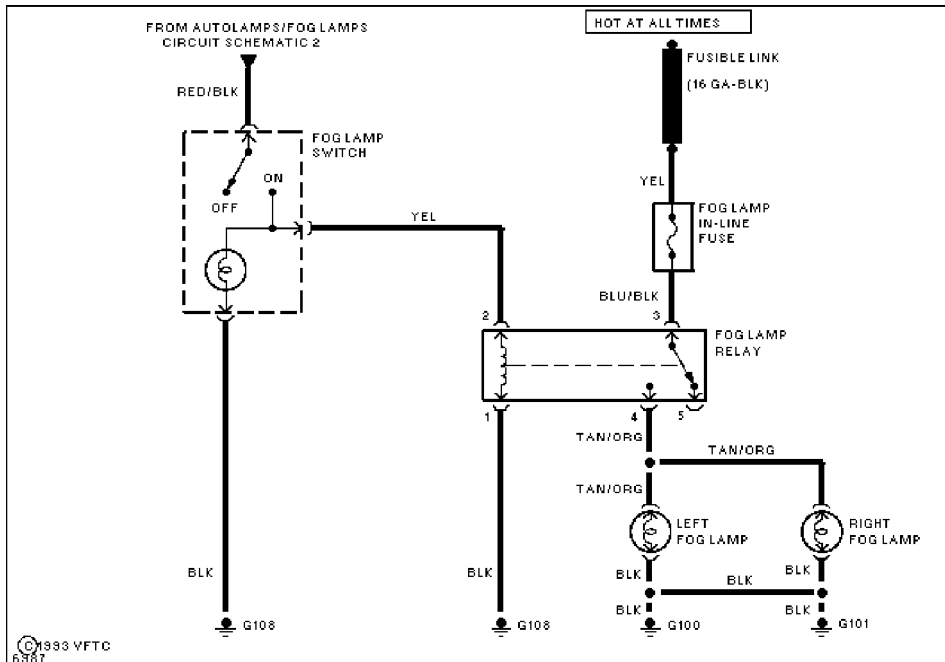

Fig. 54: Autolamps/Fog Lamps (3 of 3)

# SUB-CIRCUIT DIAGRAMS

## Selected Block (p. 6)

1990 Ford Taurus

For <http://www.mitchell.narod.ru/>

Copyright © 1997 Mitchell International

Friday, March 02, 2001 02:15PM

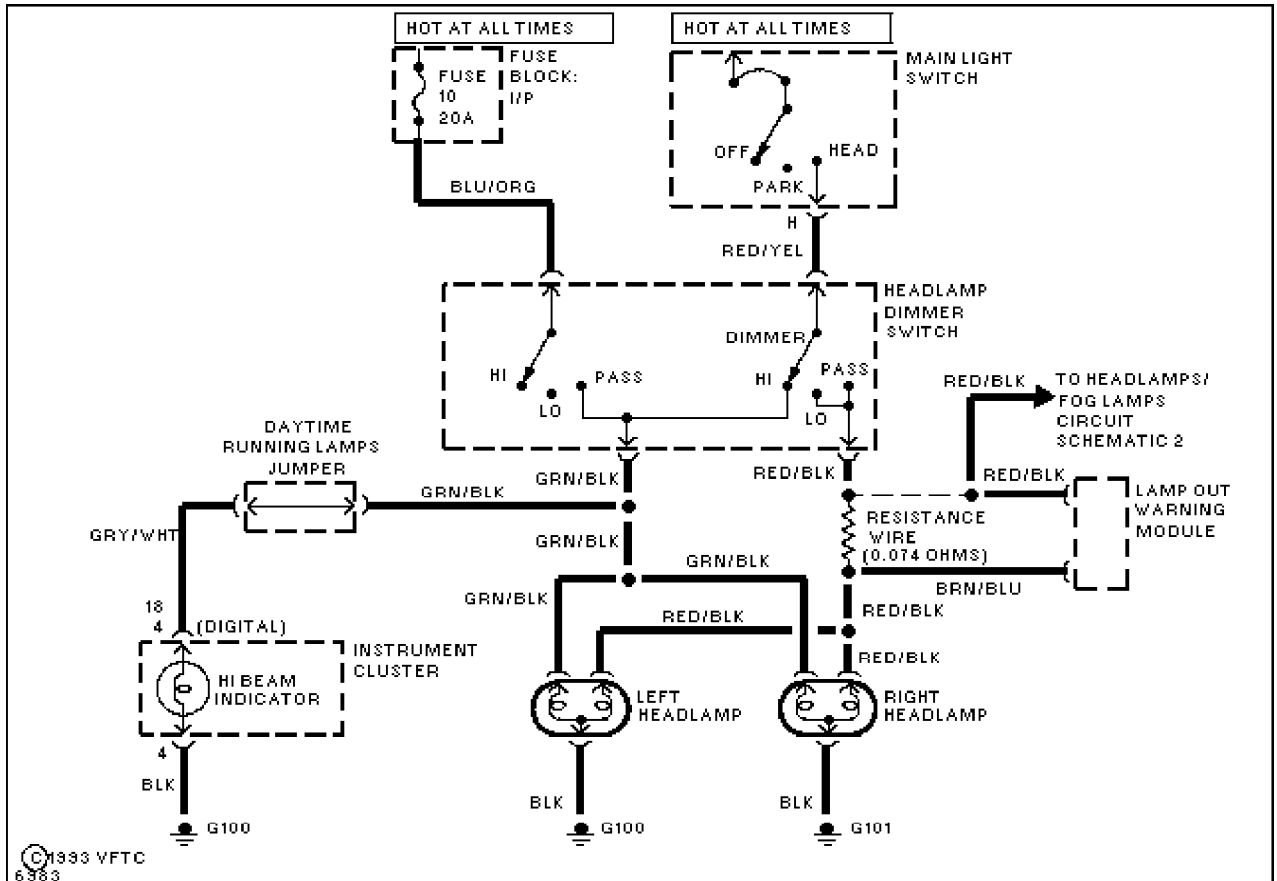

Fig. 55: Headlamps/Fog Lamps (1 of 2)

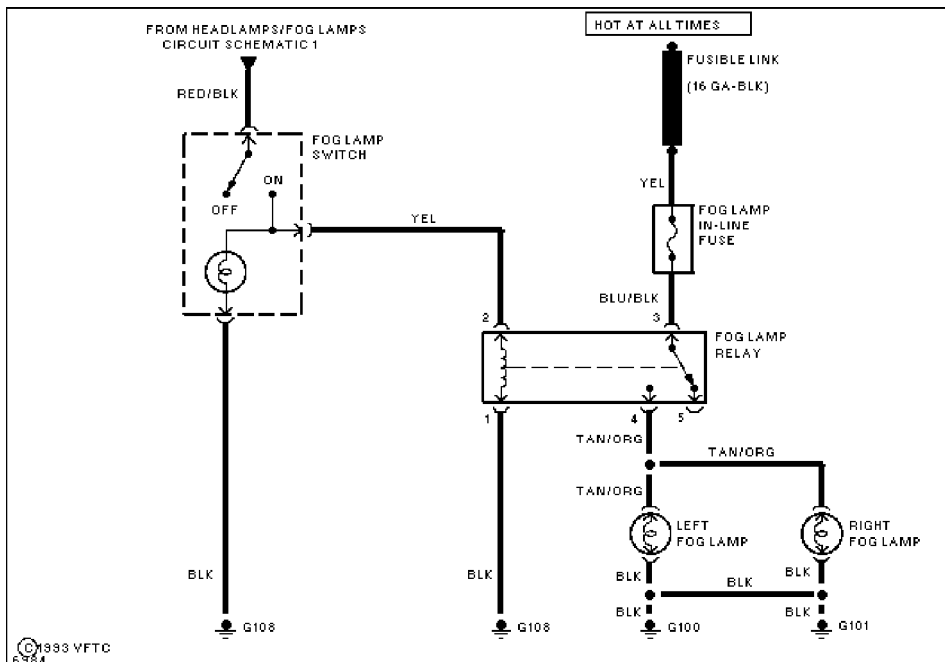

Fig. 56: Headlamps/Fog Lamps (2 of 2)