

WIRING DIAGRAMS

Selected Block

1990 Ford Taurus

For <http://www.mitchell.narod.ru/>

Copyright © 1997 Mitchell International

Friday, March 02, 2001 02:19PM

ARTICLE BEGINNING

1990 Wiring Diagrams
Ford Motor Co.

Sable & Taurus

COMPONENT LOCATION MENU

COMPONENT LOCATIONS TABLE

AA

Component	Figure No. (Location)
A/C Clutch Cycling Pressure Switch	10 (C 37)
A/C Clutch Cycling Pressure Switch (3.0L SHO)	10 (D 37)
A/C/Heater Function Switch	10 (B-D 36)
ABS Control Module	9 (A 32-35)
Air Bag Back-Up Power Supply	9 (D 32)
Air Bag Diag Module	9 (D-E 32)
Alt Output Control Relay	2 (B 5)
Alternators	2 (A-E 4-7)
Analog/SHO Instrument Cluster	13 (A 48-51)
Anti-Lock Motor Relay	9 (C 32)
Anti-Lock Power Relay	9 (C 35)
Autolamp Sys	12 (E 46-47)
Backup Light Switch (M/T)	15 (D 57)
Batteries	2 (A-E 4-7)
Blower Motor (with EATC)	10 (A 39)
Cigar Light Assy	12 (D 44)
Clutch Switch (3.0L SHO M/T)	6 (B 21)
Courtesy Lights	12 (A-C 44-47)
Cruise Control Servo	8 (E 28)
Diag Warn Mod	11 (A-B 43)
DIS Module (3.0L SHO)	5 (D 16)
Door Ajar Switches	15 (C 56)
Dual Brake Warning Switch	13 (C 48)
EATC Control Mod	10 (A-B 36)
Electronic Engine Control (EEC) (2.5L)	3 (B-E 8)
Electronic Engine Control (EEC) (3.0L SHO)	5 (A 16-19)
Electronic Engine Control (EEC) (3.8L)	7 (A 24-27)
Electronic Instrument Cluster	13 (E 49-51)
Engine Compartment Light	1 (E 2)
Engine Sensors (3.0L SHO)	6 (A 20-21)
Engine Sensors (3.8L)	6 (E 22-23)
Fog Light Relay	1 (D 3)
Fog Light Switch (3.0L SHO)	11 (E 43)
Fog Lights In-Line Fuse	1 (D 3)
Fus Links	2 (A-E 4-7)
Fuse Block	8 (C-D 29-30)
Heated Windshield	10 (E 39)
Heated Windshield Control Mod	10 (D 39)
Heated Windshield Fus Link	10 (D 38)

WIRING DIAGRAMS

Selected Block (p. 2)

1990 Ford Taurus

For <http://www.mitchell.narod.ru/>

Copyright © 1997 Mitchell International

Friday, March 02, 2001 02:19PM

Heater Function Sel Switch	10	(B 39)
HEGO Sens (2.5L)	3	(D 10)
HEGO Sens (3.0L)	4	(D 14)
HEGO Sensors (3.0L SHO)	5	(E 18)
HEGO Sensors (3.8L)	7	(E 26)
Horn Relay	11	(D 41)
Ignition Coil (2.5L)	3	(B 11)
Ignition Coil (3.0L)	4	(B 15)
Ignition Coil (3.8L)	7	(D 24)
Ignition Switch	8	(A-C 28)
Ignition Switch Fus Links	8	(B 30)
Illum Entry Timer	15	(B 56)
Instrument Panel Dimming Rheostat	12	(D 47)
Integrated Control Mod (ICM) (2.5L)	3	(A-B 11)
Integrated Control Mod (ICM) (3.0L SHO)	6	(A 22-23)
Integrated Control Mod (ICM) (3.8L)	6	(E 20-21)
Interval Wiper/Washer Mod	11	(E 40)
Keyless Entry Sys	14	(B-C 54-55)
Liftgate Release Relay	15	(D 56)
Low Oil Level Relay	13	(B 51)
Main Light Switch	12	(E 44)
Master Window Control Switch	14	(B-D 52)
Moonroof	15	(B-C 57-58)
Multi-Function Switch	11	(A-D 40)
Neutral/Safety/Back-Up Light Switch (A/T)	8	(A-B 31)
Police Accy Relay	15	(B 56)
Power Antenna	15	(E 57)
Power Door Locks (with Keyless Entry)	14	(A 52-55)
Power Door Locks (without Keyless Entry)	15	(A 56-59)
Power Mirrors	14	(D-E 54-55)
Power Seats	14	(D-E 52-54)
Power Window Safety Relay	14	(A 52)
Rear Window Defog Control	11	(E 43)
Rear Wiper/Washer System	15	(E 56-57)
Self Test Output (STO) Conn (2.5L)	3	(C 10)
Self Test Output (STO) Conn (3.0L SHO)	5	(E 18-19)
Self Test Output (STO) Conn (3.0L)	4	(C 15)
Self Test Output (STO) Conn (3.8L)	7	(E 25-26)
Starter Relays	2	(A-E 4-7)
Steering Wheel Control Switch	11	(D 43)
Stop Light Switch	11	(C 42)
TFI Ignition Mod (3.8L)	7	(C-D 25)
Variable Assist Power Steering (VAPS) Mod	9	(E 35)
Warning Chime Mods	10	(E 36-38)
Washer Fluid Level Switch	1	(B-C 3)
Wiper Motor & Park Switch	1	(A 3)

AA

WIRING DIAGRAMS

Selected Block (p. 3)

1990 Ford Taurus

For <http://www.mitchell.narod.ru/>

Copyright © 1997 Mitchell International

Friday, March 02, 2001 02:19PM

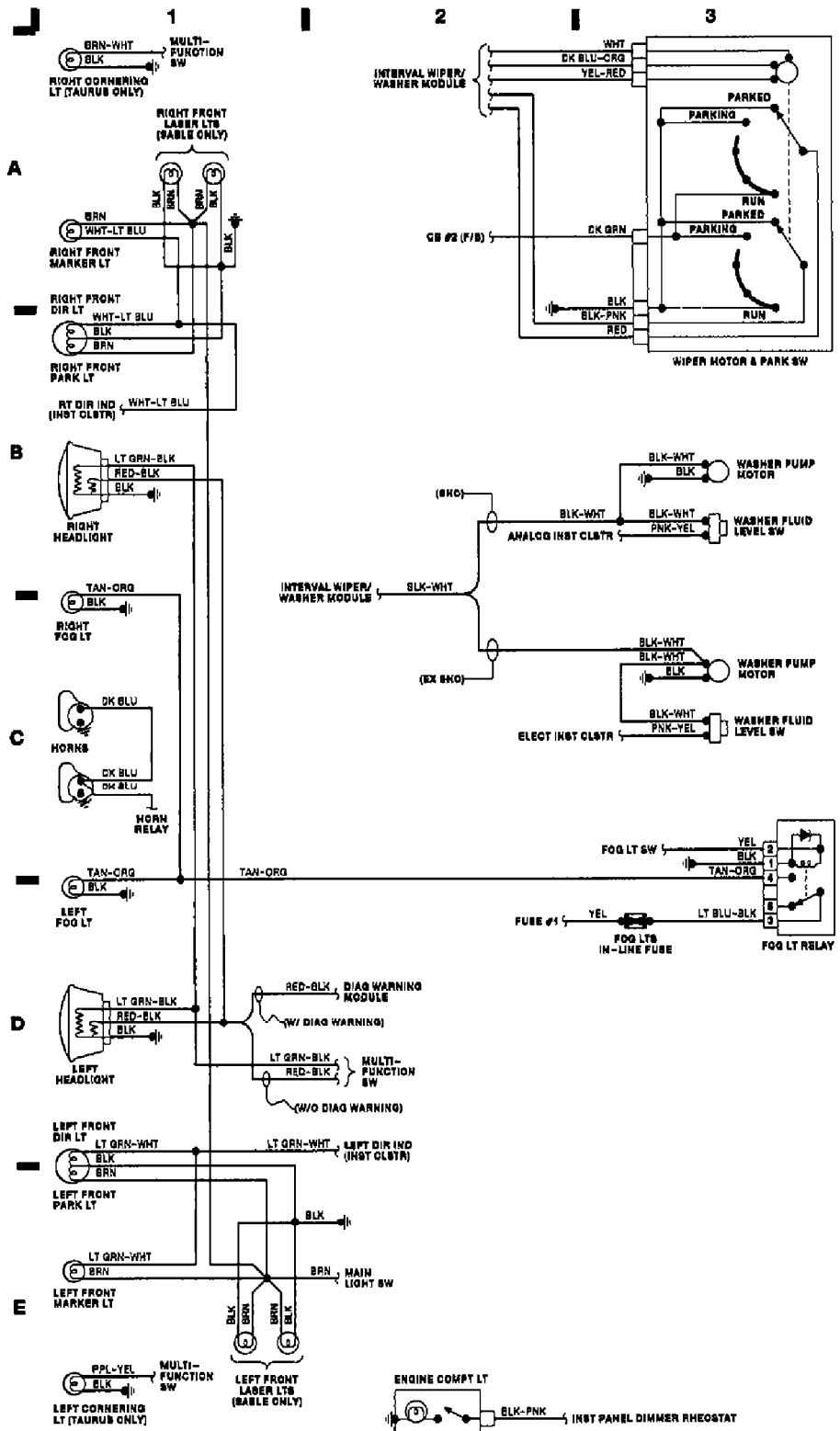

Fig. 1: Headlights & Washer/Wiper (Grid 1-3)

WIRING DIAGRAMS

Selected Block (p. 4)

1990 Ford Taurus

For <http://www.mitchell.narod.ru/>

Copyright © 1997 Mitchell International

Friday, March 02, 2001 02:19PM

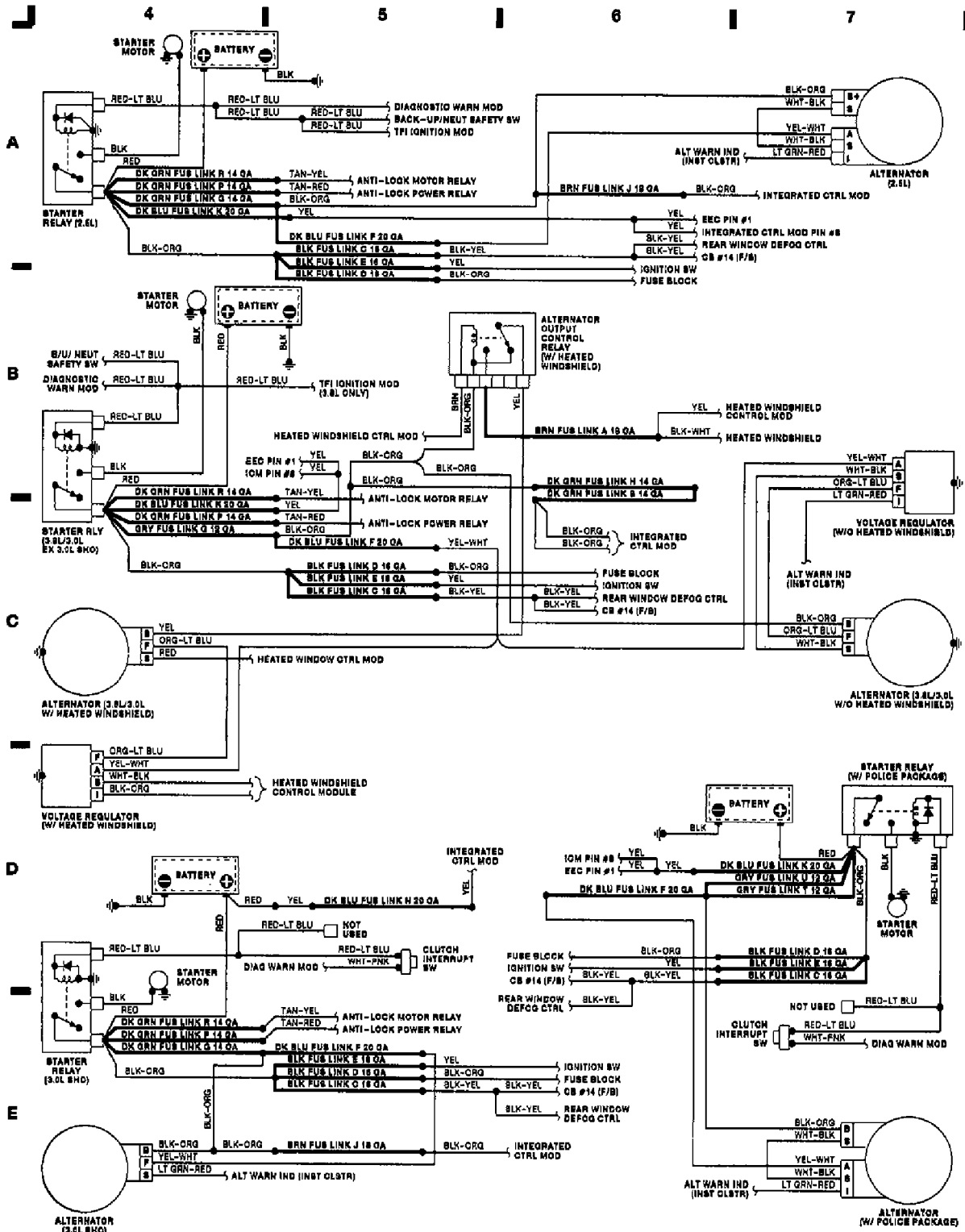

Fig. 2: Engine Compartment (Grid 4-7)

WIRING DIAGRAMS

Selected Block (p. 5)

1990 Ford Taurus

For <http://www.mitchell.narod.ru/>

Copyright © 1997 Mitchell International

Friday, March 02, 2001 02:19PM

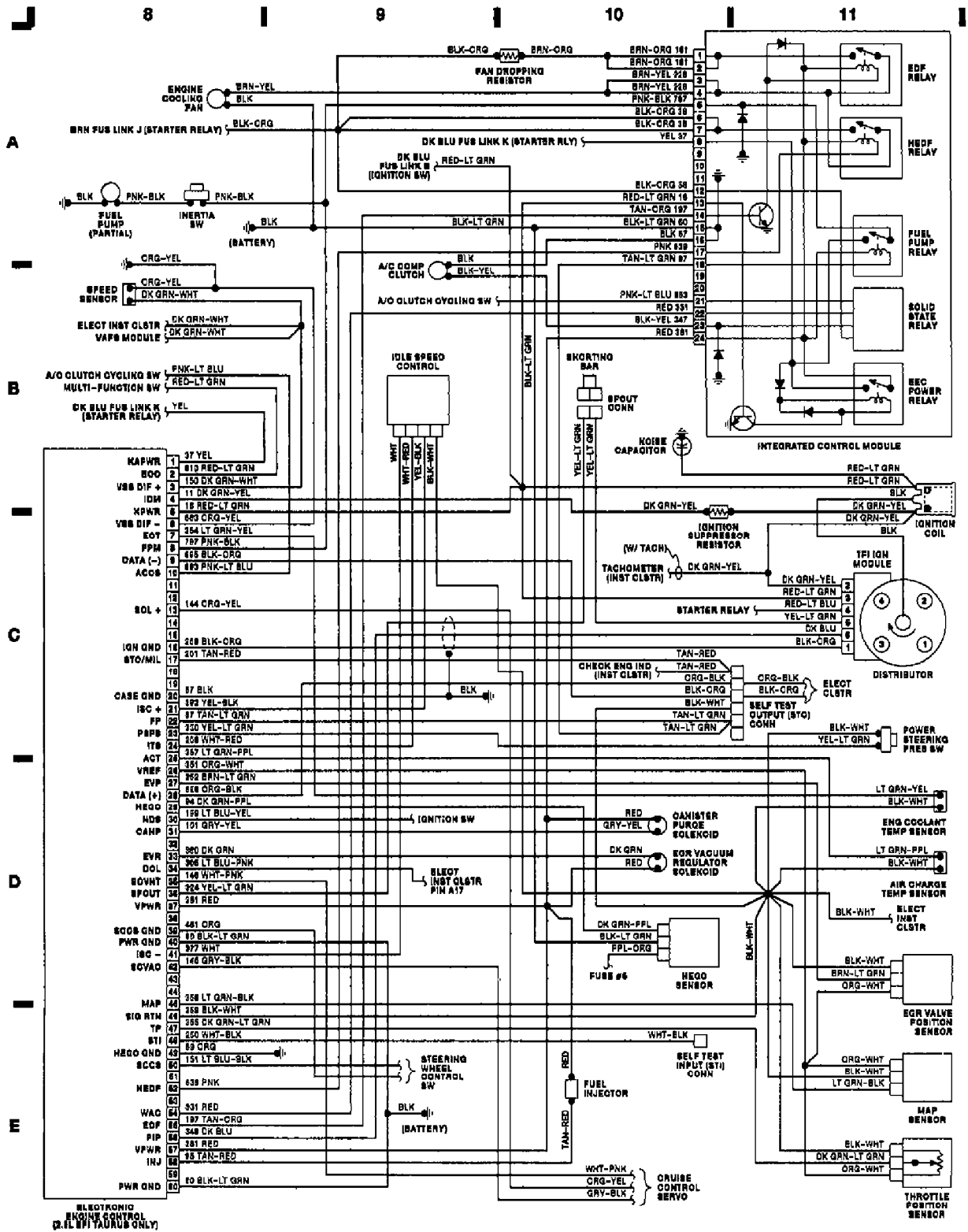

Fig. 3: Electronic Engine Control (2.5L EFI Taurus) (Grid 8-11)

WIRING DIAGRAMS

Selected Block (p. 7)

1990 Ford Taurus

For <http://www.mitchell.narod.ru/>

Copyright © 1997 Mitchell International

Friday, March 02, 2001 02:19PM

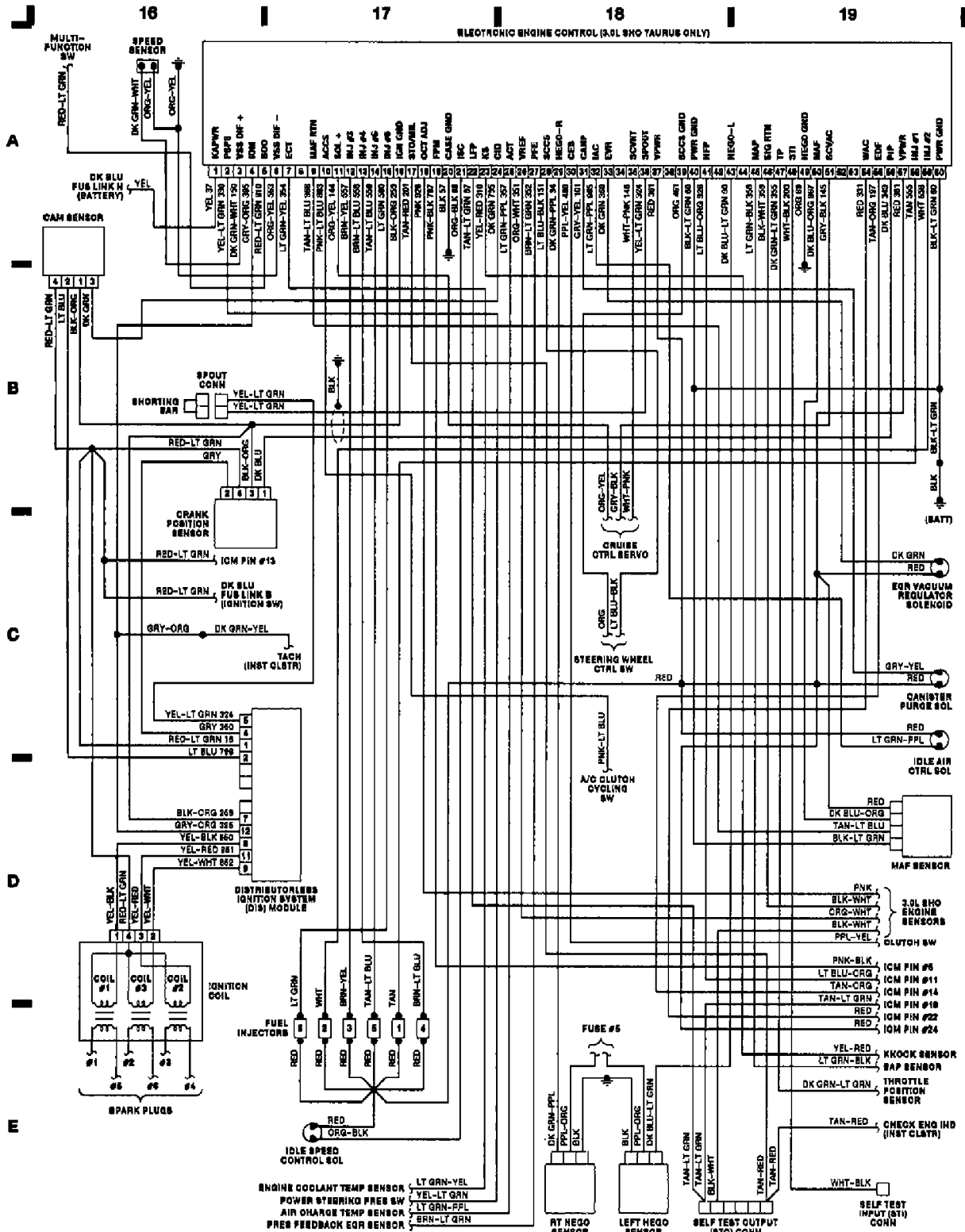

Fig. 5: Electronic Engine Control (3.0L SHO Taurus) (Grid 16-19)

WIRING DIAGRAMS

Selected Block (p. 8)

1990 Ford Taurus

For <http://www.mitchell.narod.ru/>

Copyright © 1997 Mitchell International

Friday, March 02, 2001 02:19PM

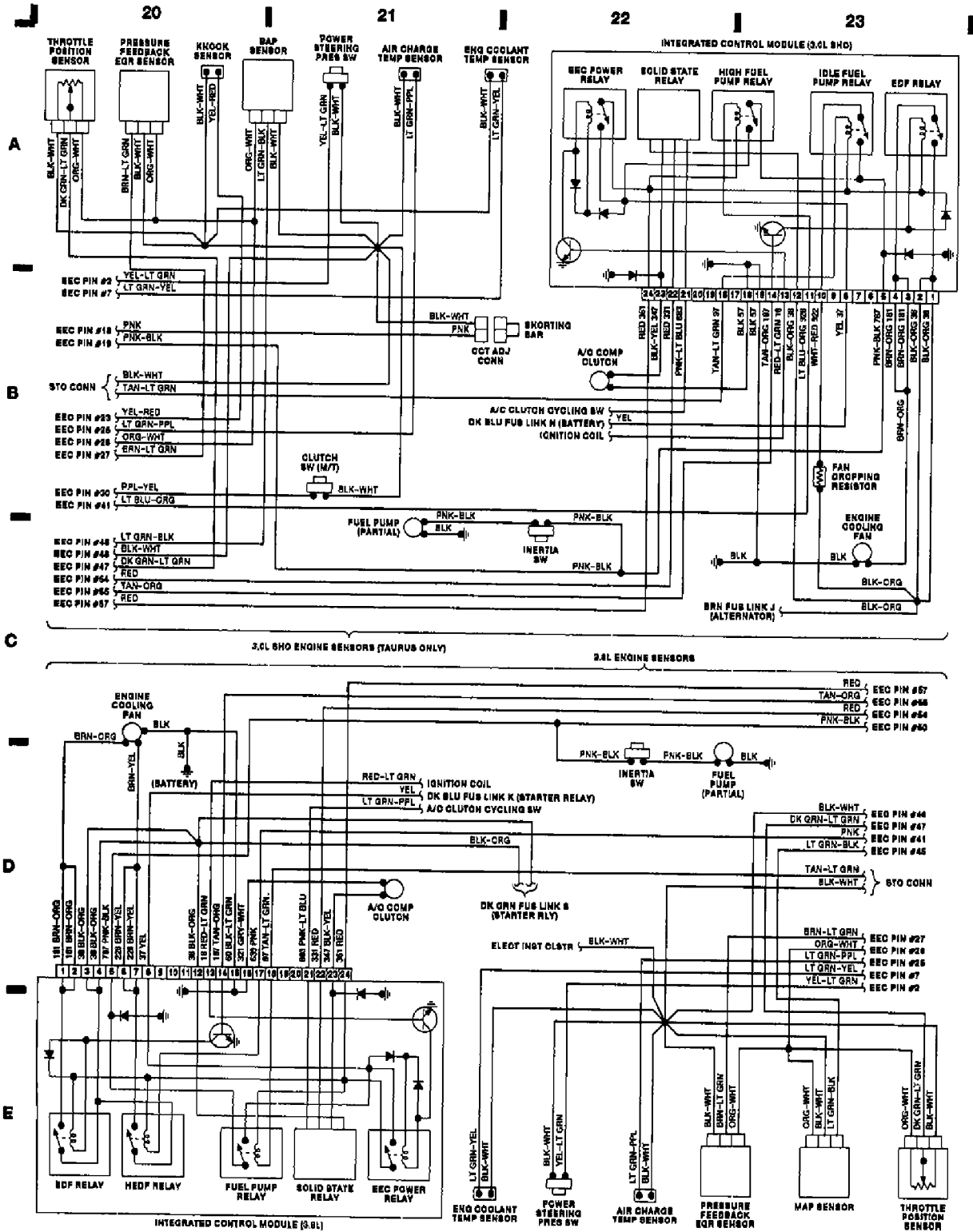

Fig. 6: Engine Sensors (Grid 20-23)