

WIRING DIAGRAMS

Selected Block

1992 Ford Taurus

For <http://www.mitchell.narod.ru/>
 Copyright © 1997 Mitchell International
 Friday, March 02, 2001 02:26PM

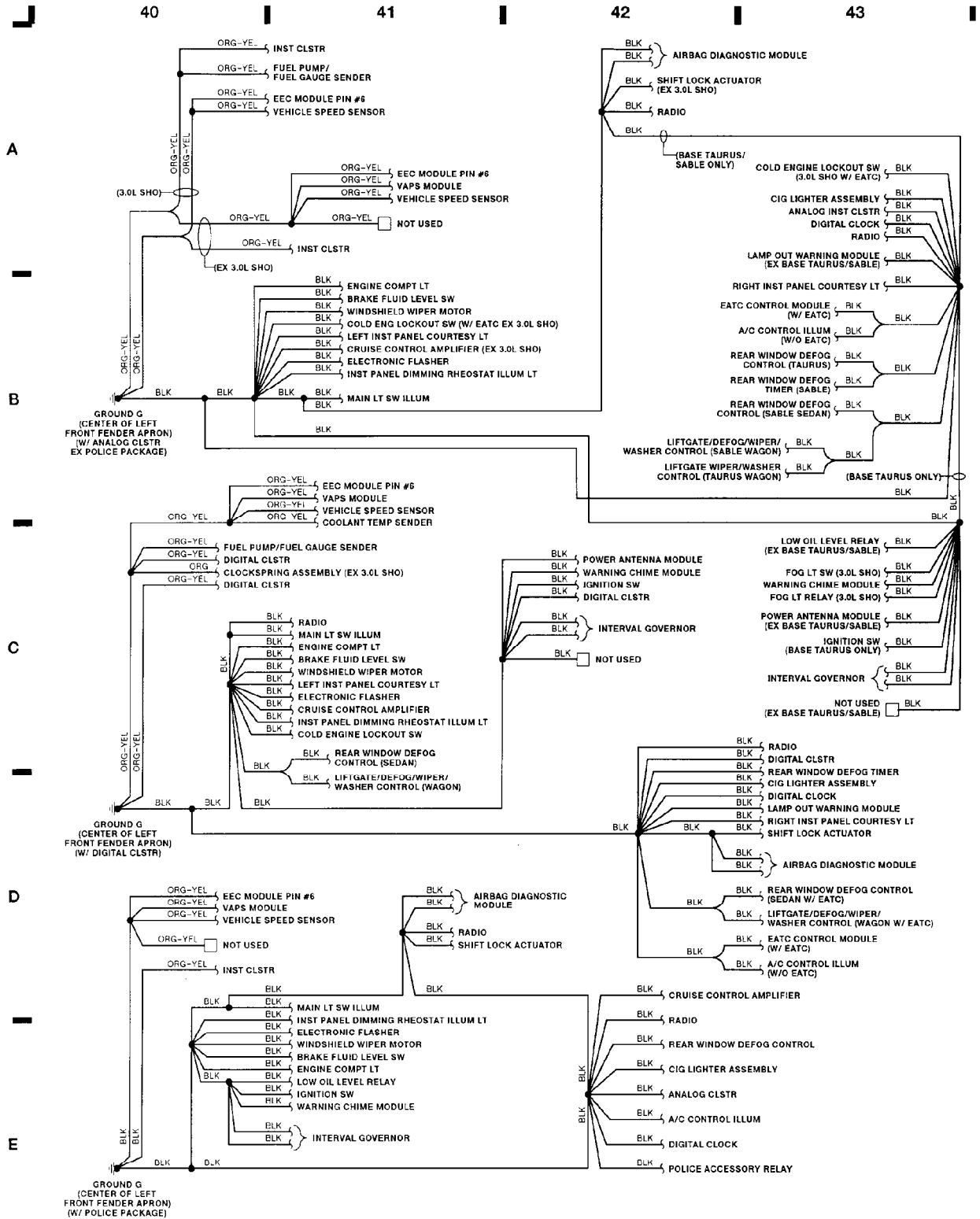

Fig. 11: Ground G Locations (All Models) (Grid 40-43)

WIRING DIAGRAMS

Selected Block (p. 2)

1992 Ford Taurus

For <http://www.mitchell.narod.ru/>

Copyright © 1997 Mitchell International

Friday, March 02, 2001 02:26PM

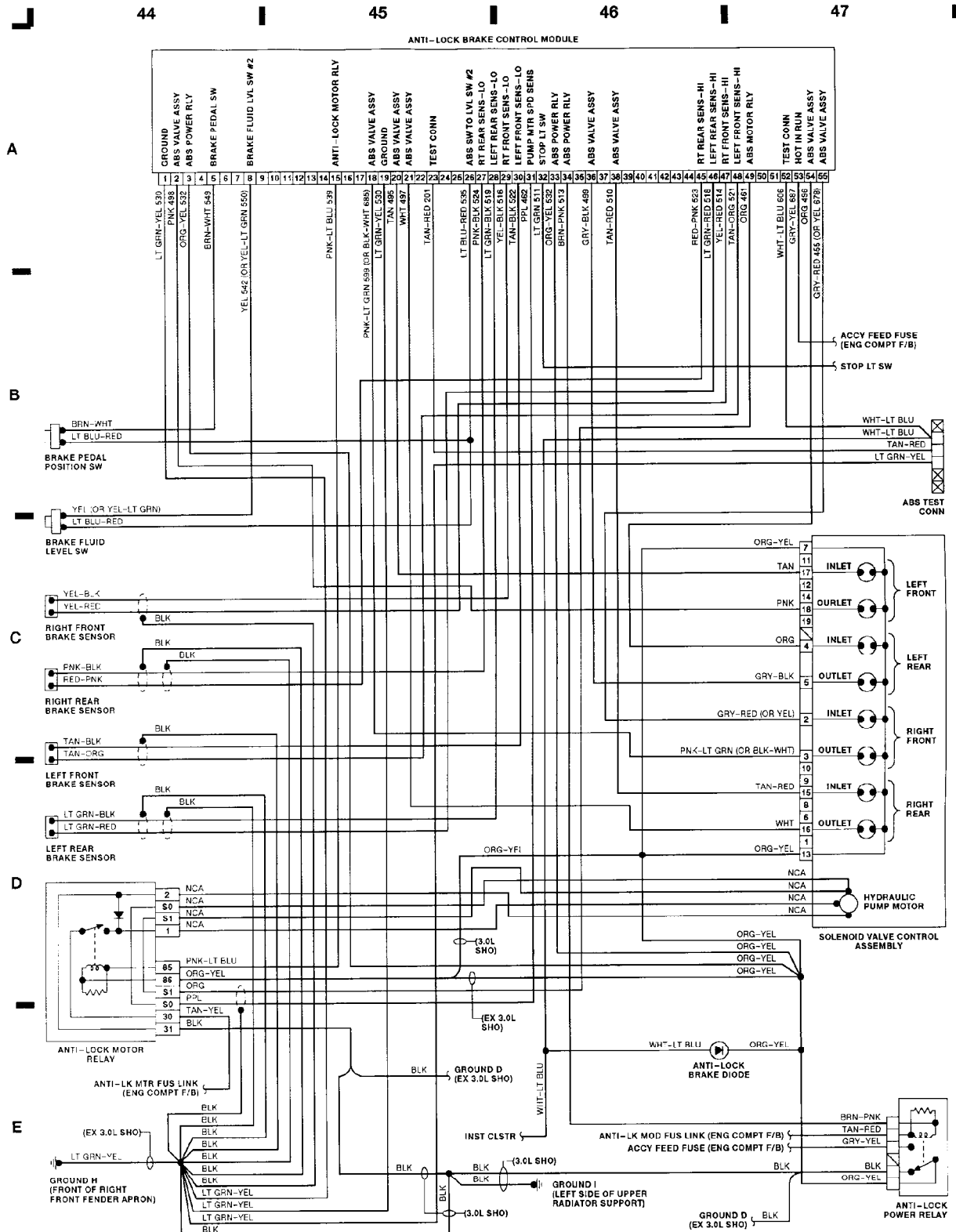

Fig. 12: Anti-Lock Brake Control Module (Grid 44-47)

WIRING DIAGRAMS

Selected Block (p. 3)

1992 Ford Taurus

For <http://www.mitchell.narod.ru/>

Copyright © 1997 Mitchell International

Friday, March 02, 2001 02:26PM

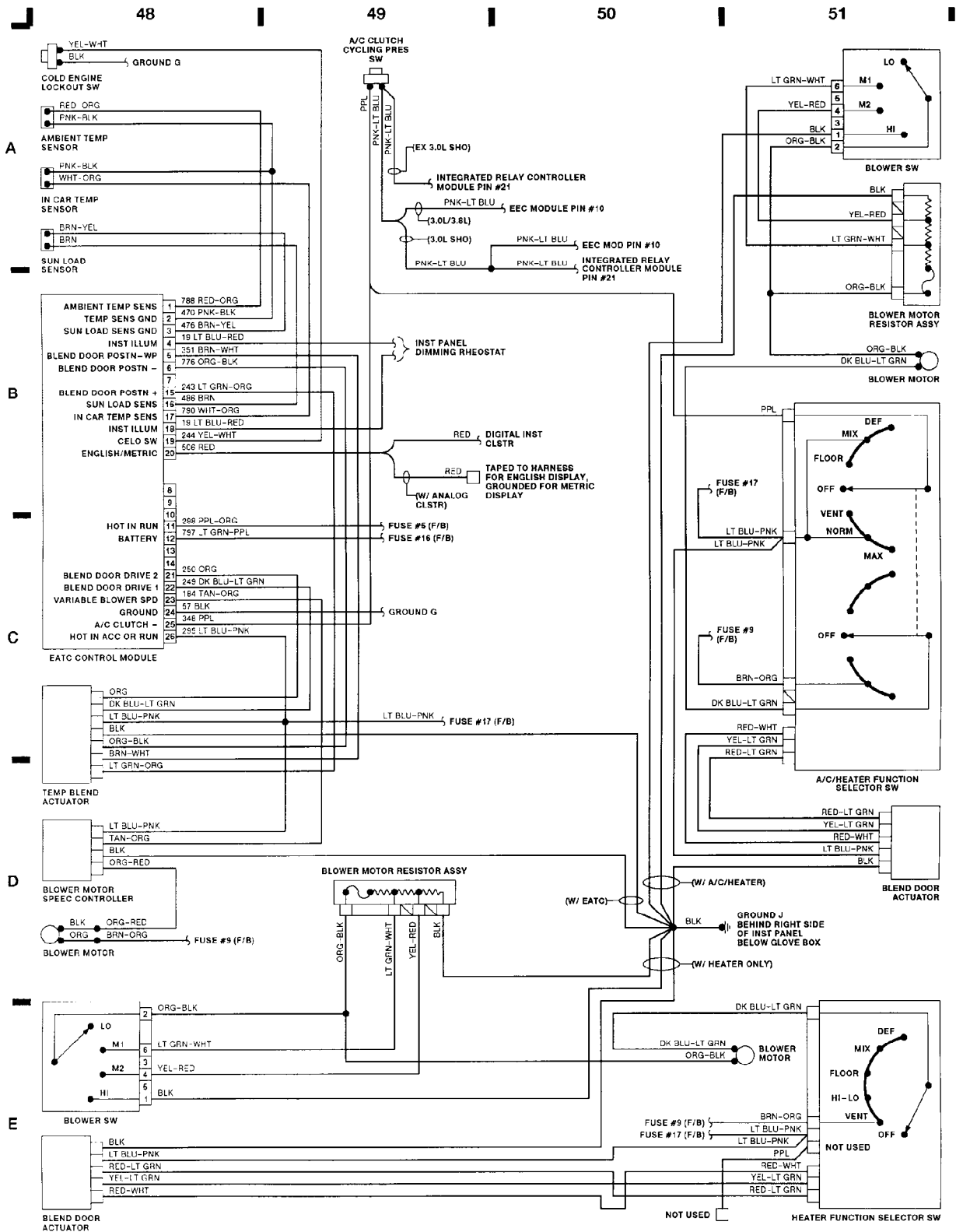

Fig. 13: EACT Control Module, A/C & Heater System (Grid 48-51)

WIRING DIAGRAMS

Selected Block (p. 4)

1992 Ford Taurus

For <http://www.mitchell.narod.ru/>

Copyright © 1997 Mitchell International

Friday, March 02, 2001 02:26PM

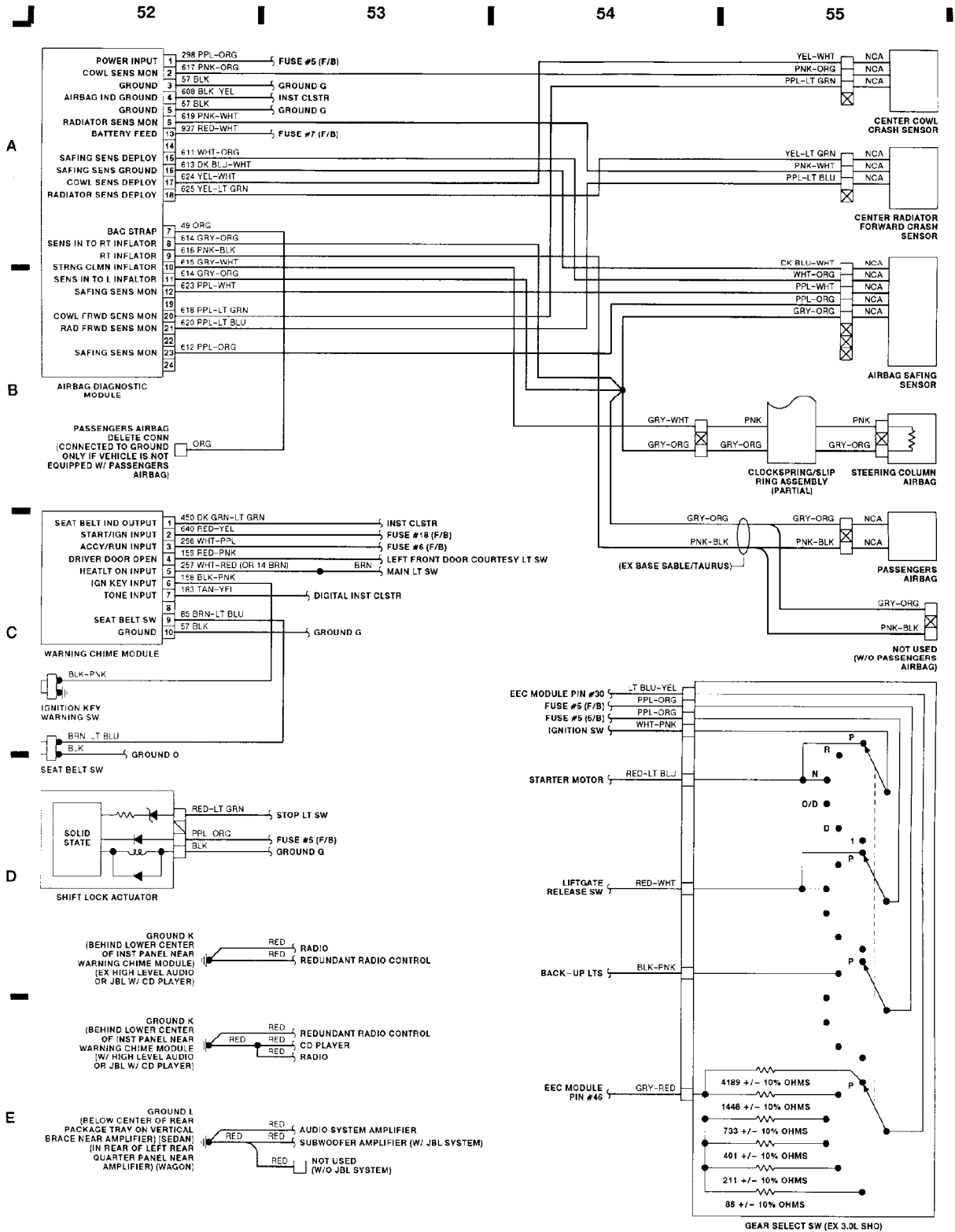

Fig. 14: Air Bag, Gear Select Sw, Warning Chime Mod (Grid 52-55)

WIRING DIAGRAMS

Selected Block (p. 5)

1992 Ford Taurus

For <http://www.mitchell.narod.ru/>

Copyright © 1997 Mitchell International

Friday, March 02, 2001 02:26PM

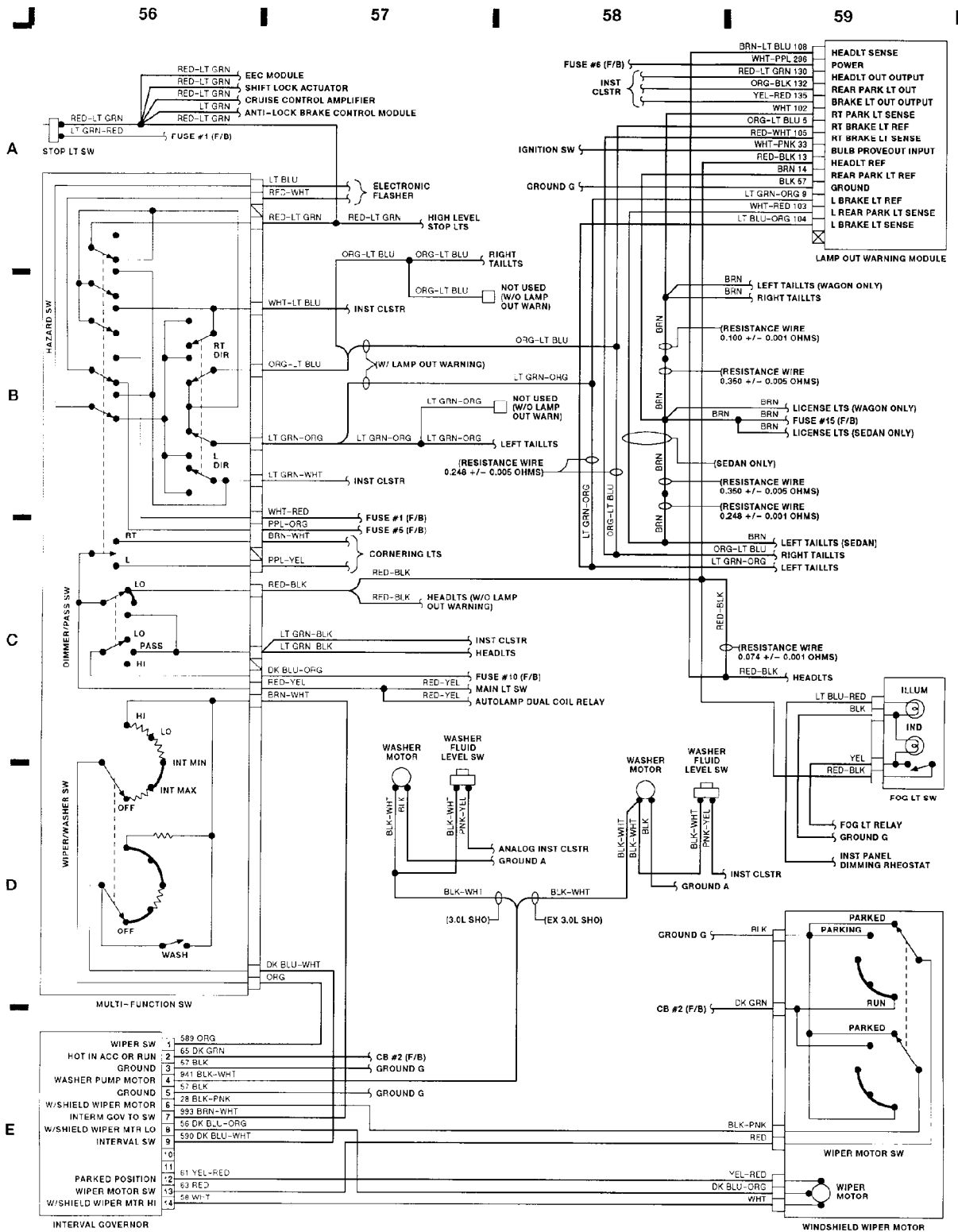

Fig. 15: Multi-Function Sw, Lamp Out Warning Module (Grid 56-59)