

# WIRING DIAGRAMS

## Selected Block

### 1992 Ford Taurus

For <http://www.mitchell.narod.ru/>  
 Copyright © 1997 Mitchell International  
 Friday, March 02, 2001 02:26PM

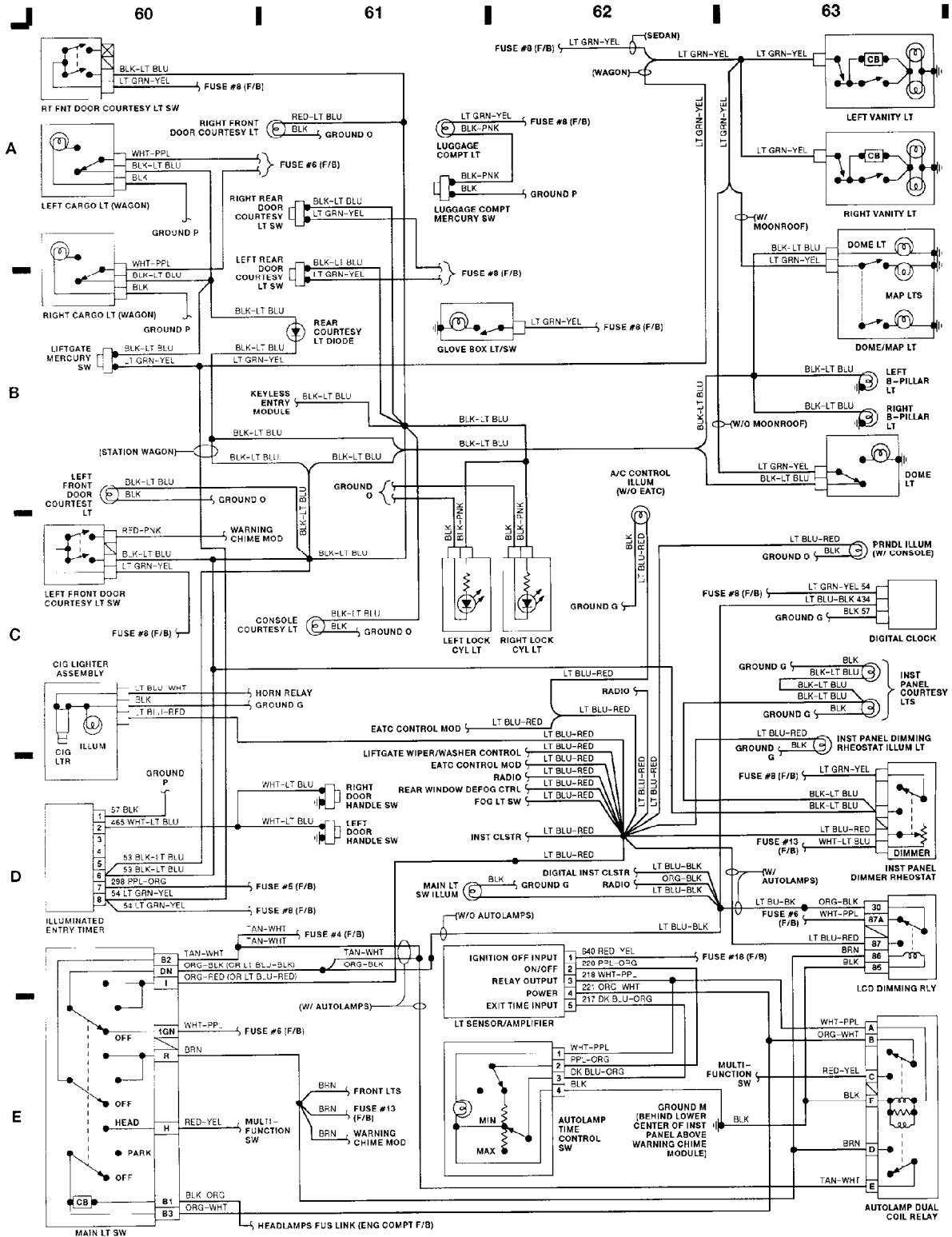

Fig. 16: Main Light Switch, Courtesy Lights (Grid 60-63)

# WIRING DIAGRAMS

## Selected Block (p. 2)

1992 Ford Taurus

For <http://www.mitchell.narod.ru/>

Copyright © 1997 Mitchell International

Friday, March 02, 2001 02:26PM

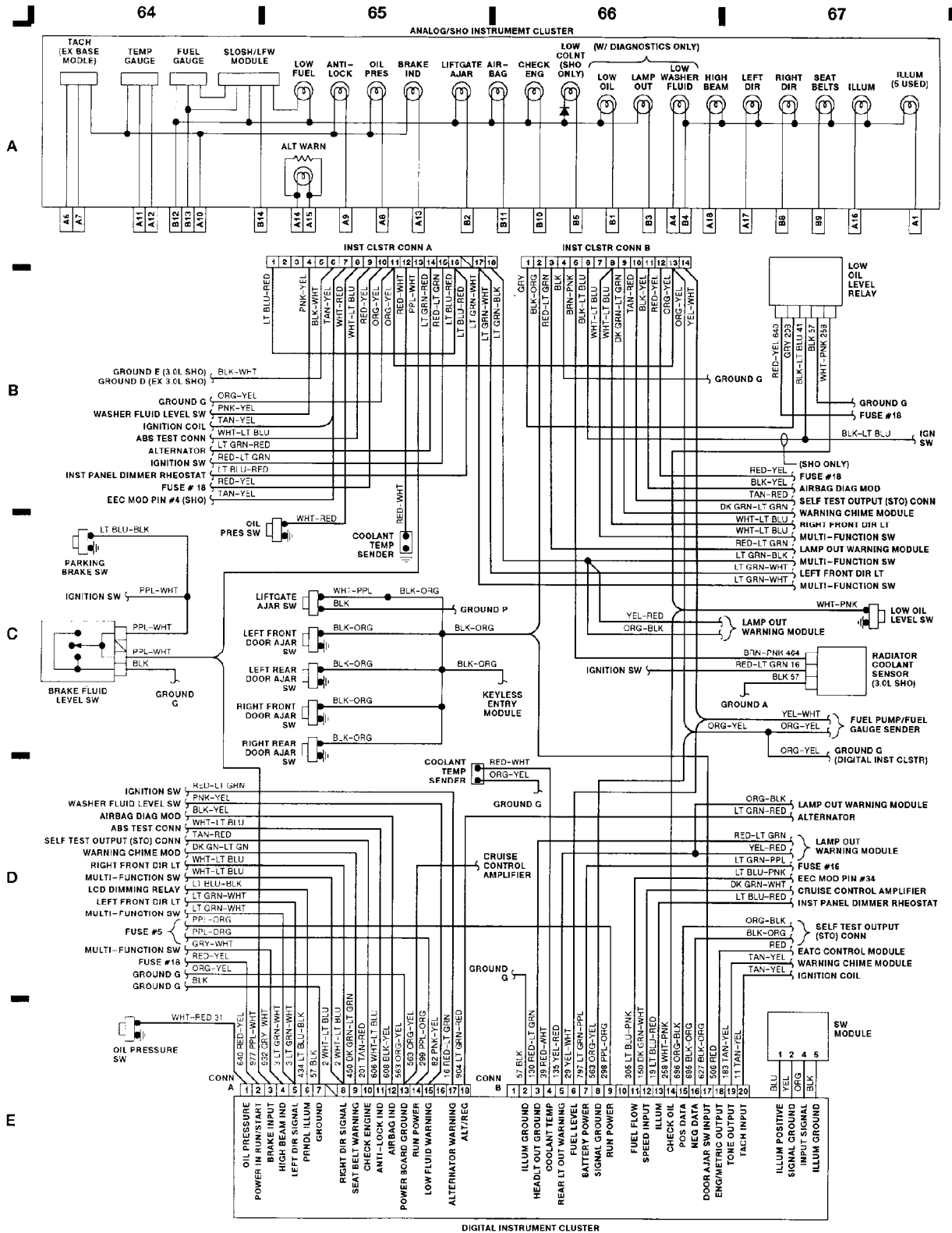

Fig. 17: Analog/SHO & Digital Instrument Panel (Grid 64-67)

# WIRING DIAGRAMS

## Selected Block (p. 3)

1992 Ford Taurus

For <http://www.mitchell.narod.ru/>

Copyright © 1997 Mitchell International

Friday, March 02, 2001 02:26PM

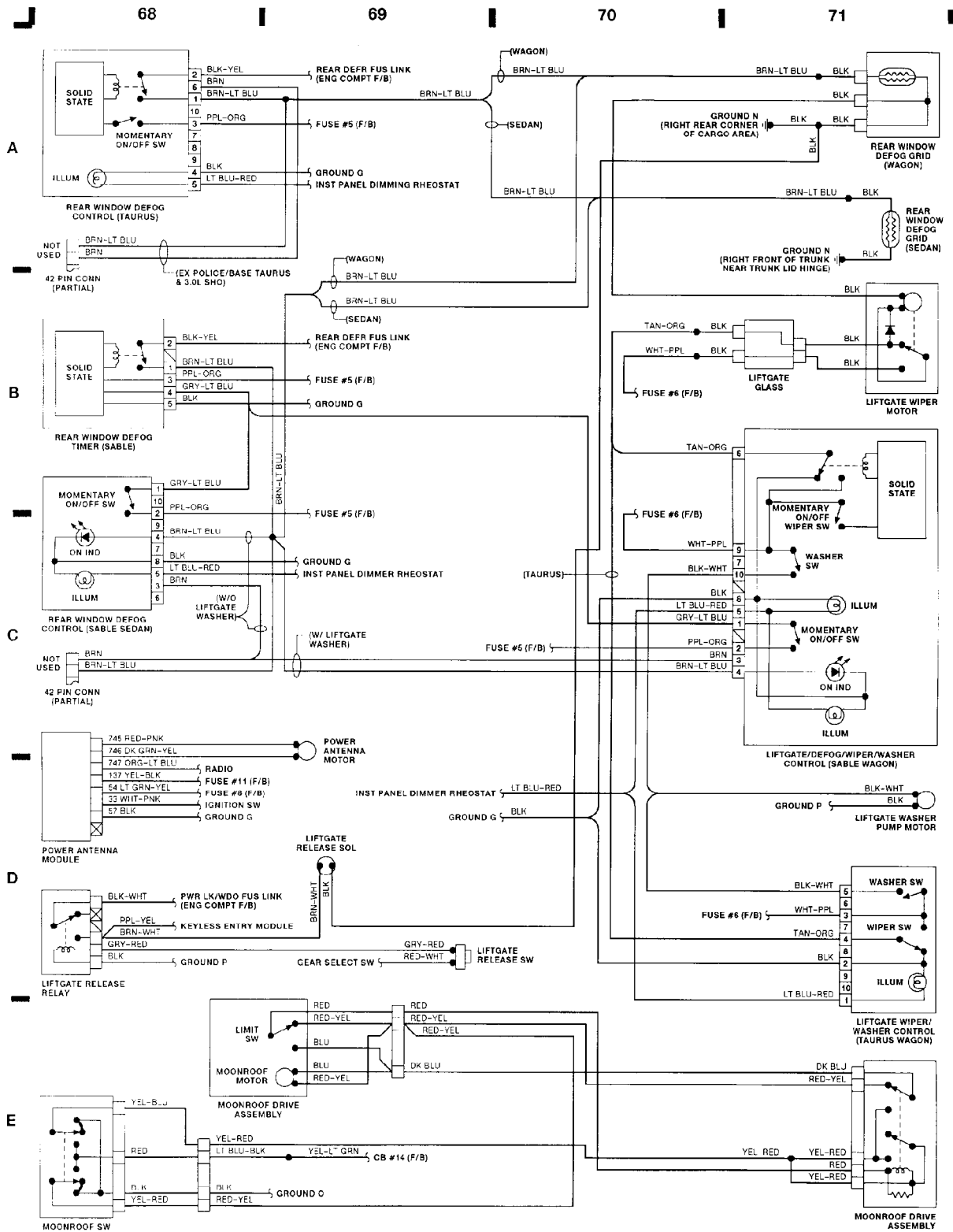

Fig. 18: Power Antenna/Moonroof, Rear Defogger, Liftgate (Grid 68-71)

# WIRING DIAGRAMS

## Selected Block (p. 4)

1992 Ford Taurus

For <http://www.mitchell.narod.ru/>

Copyright © 1997 Mitchell International

Friday, March 02, 2001 02:26PM

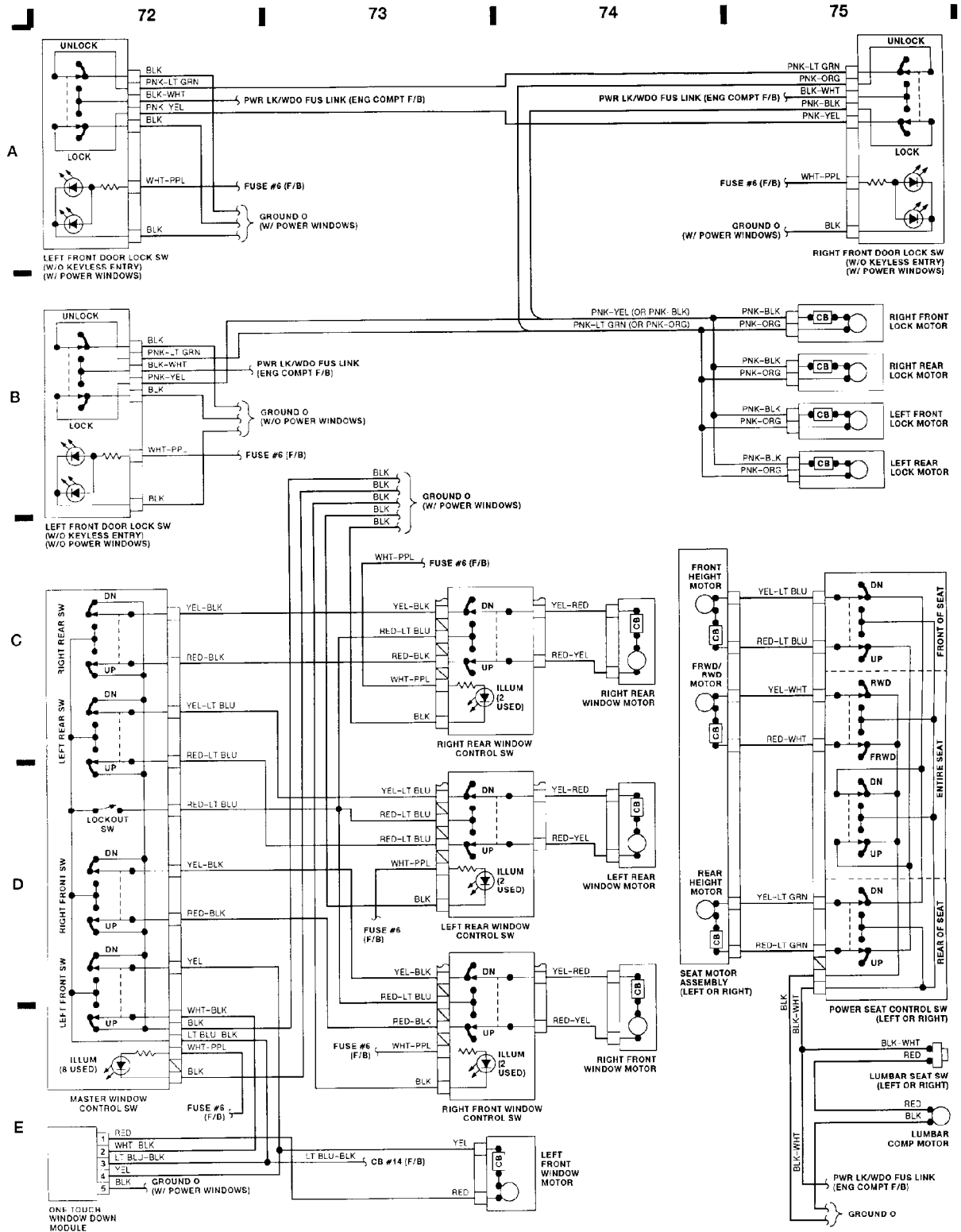

Fig. 19: Pwr Windows/Seats, Pwr Doors W/O Keyless Entry (Grid 72-75)

# WIRING DIAGRAMS

## Selected Block (p. 5)

1992 Ford Taurus

For <http://www.mitchell.narod.ru/>

Copyright © 1997 Mitchell International

Friday, March 02, 2001 02:26PM

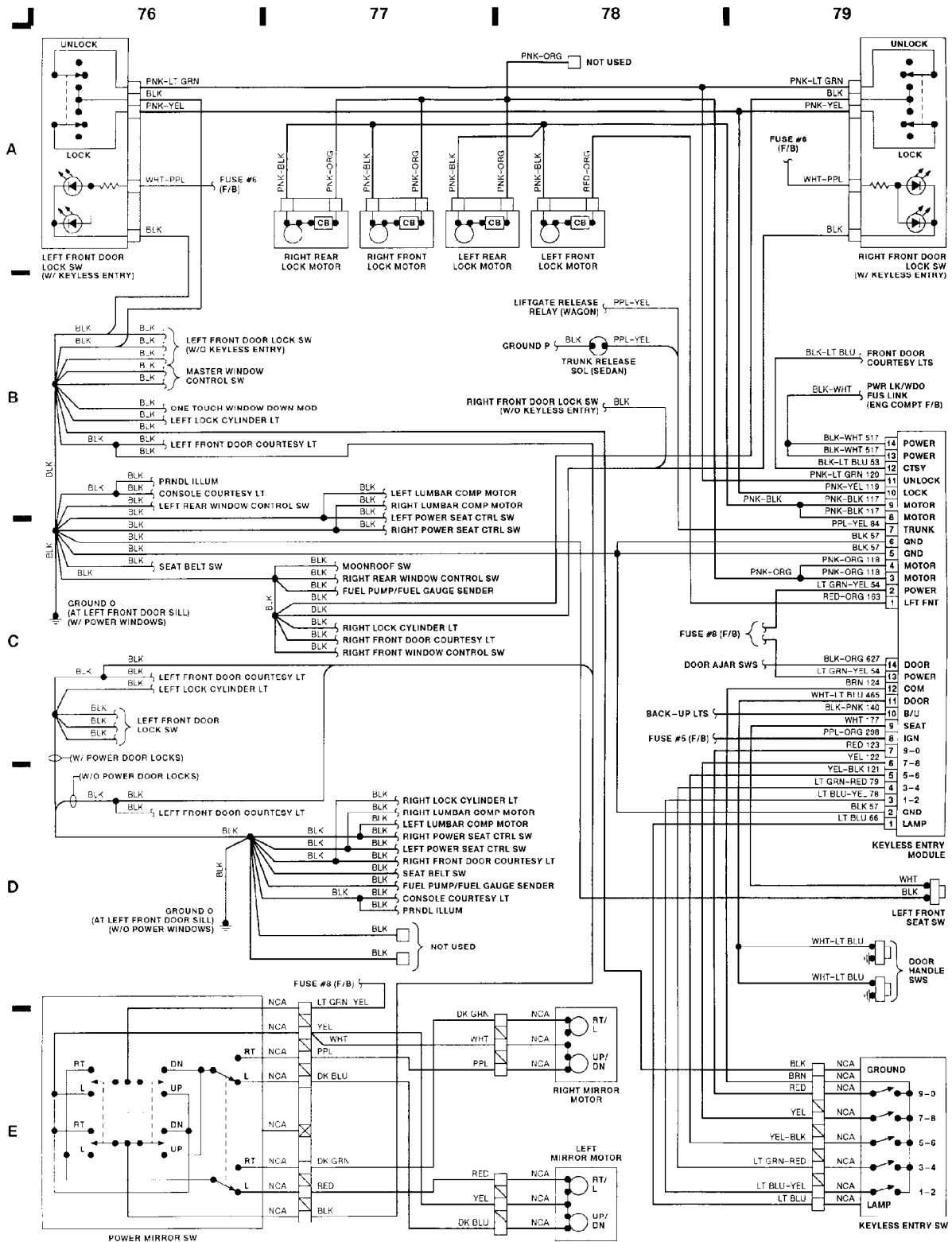

Fig. 20: Power Mirror, Power Doors W/Keyless Entry (Grid 76-79)

# WIRING DIAGRAMS

## Selected Block (p. 6)

1992 Ford Taurus

For <http://www.mitchell.narod.ru/>

Copyright © 1997 Mitchell International

Friday, March 02, 2001 02:26PM

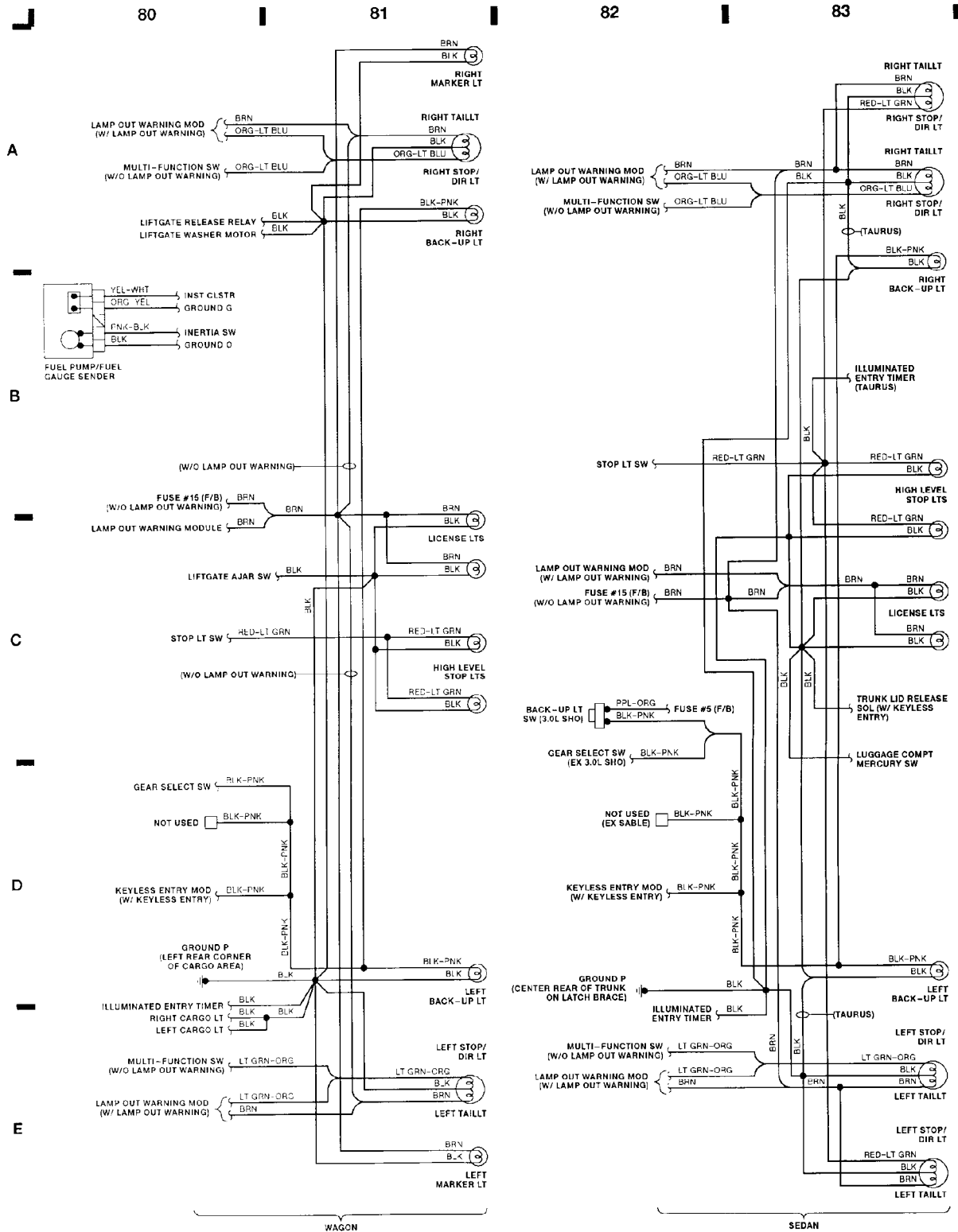

Fig. 21: Taillights (Wagon & Sedan) (Grid 80-83)

END OF ARTICLE