

WIRING DIAGRAMS

Selected Block

1993 Ford Taurus

For <http://www.mitchell.narod.ru/>
 Copyright © 1997 Mitchell International
 Friday, March 02, 2001 02:28PM

ENGINE CONTROL SYSTEM WIRING DIAGRAMS

3.0L EXCEPT SHO

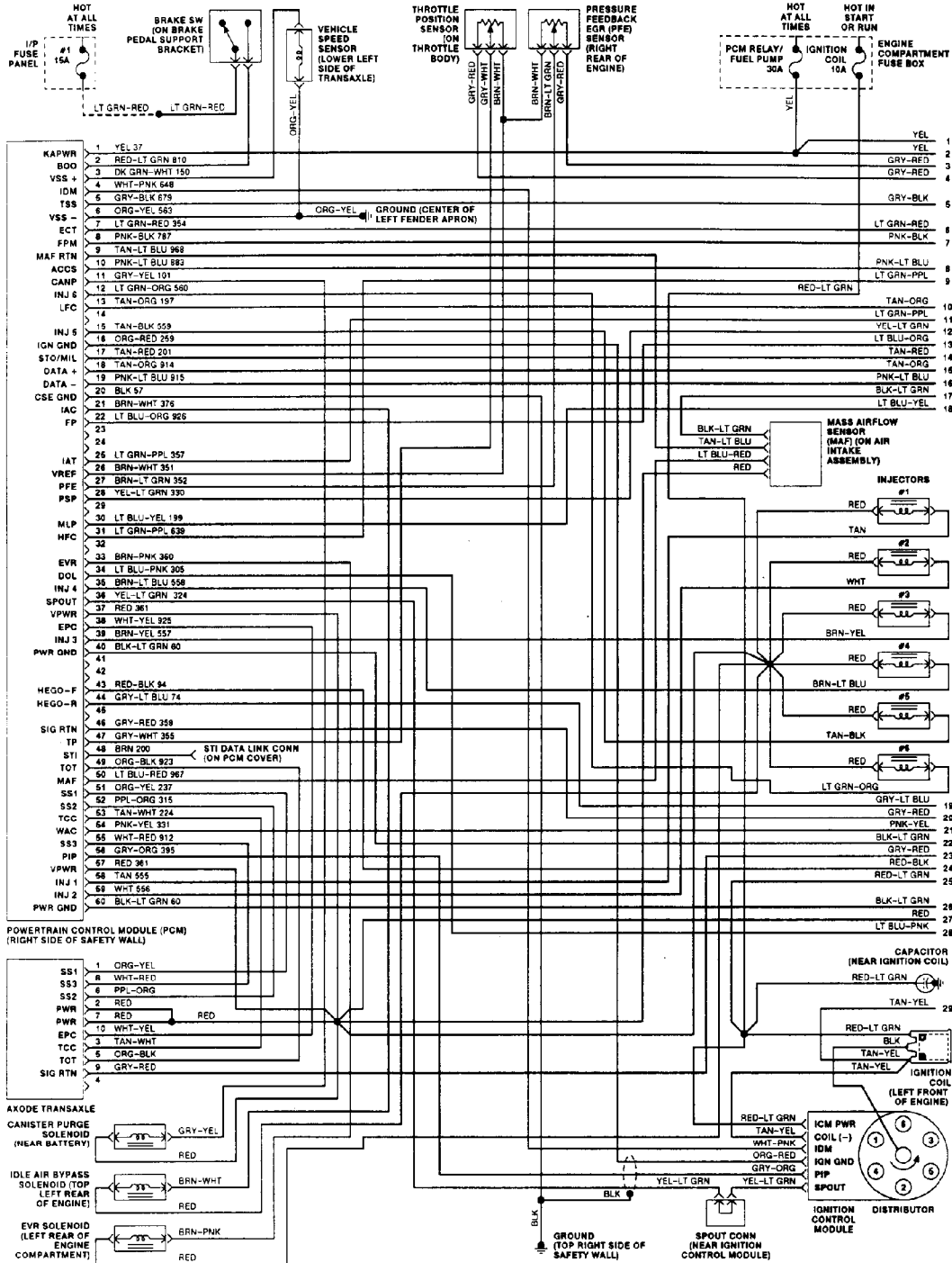

93J40658

Fig. 18: EEC-IV Wiring Diagram (3.0L Except SHO 1 of 2)

WIRING DIAGRAMS

Selected Block (p. 3)

1993 Ford Taurus

For <http://www.mitchell.narod.ru/>

Copyright © 1997 Mitchell International

Friday, March 02, 2001 02:28PM

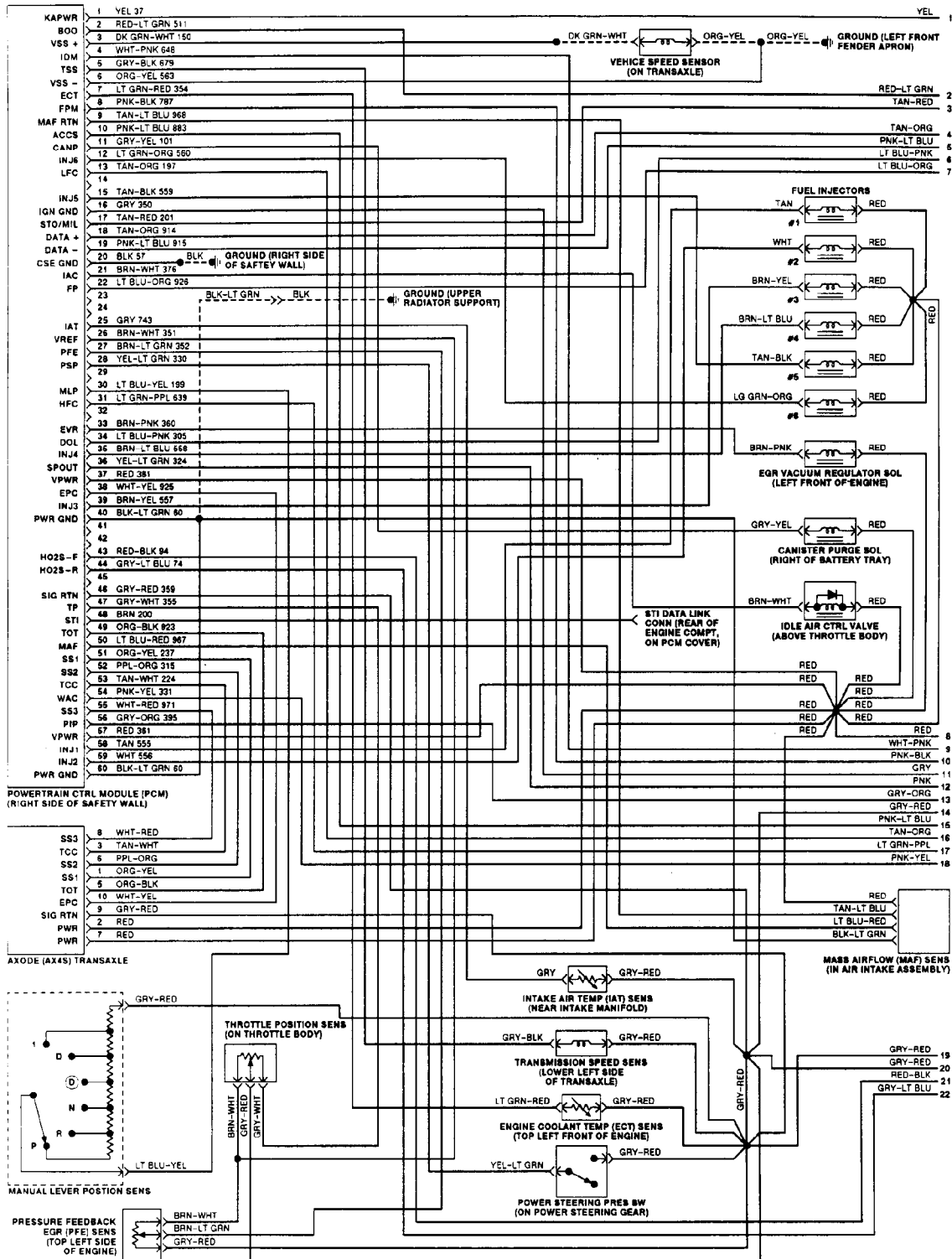

93D40660

Fig. 20: EEC-IV Wiring Diagram (3.8L - 1 of 2)

WIRING DIAGRAMS

Selected Block (p. 4)

1993 Ford Taurus

For <http://www.mitchell.narod.ru/>

Copyright © 1997 Mitchell International

Friday, March 02, 2001 02:28PM

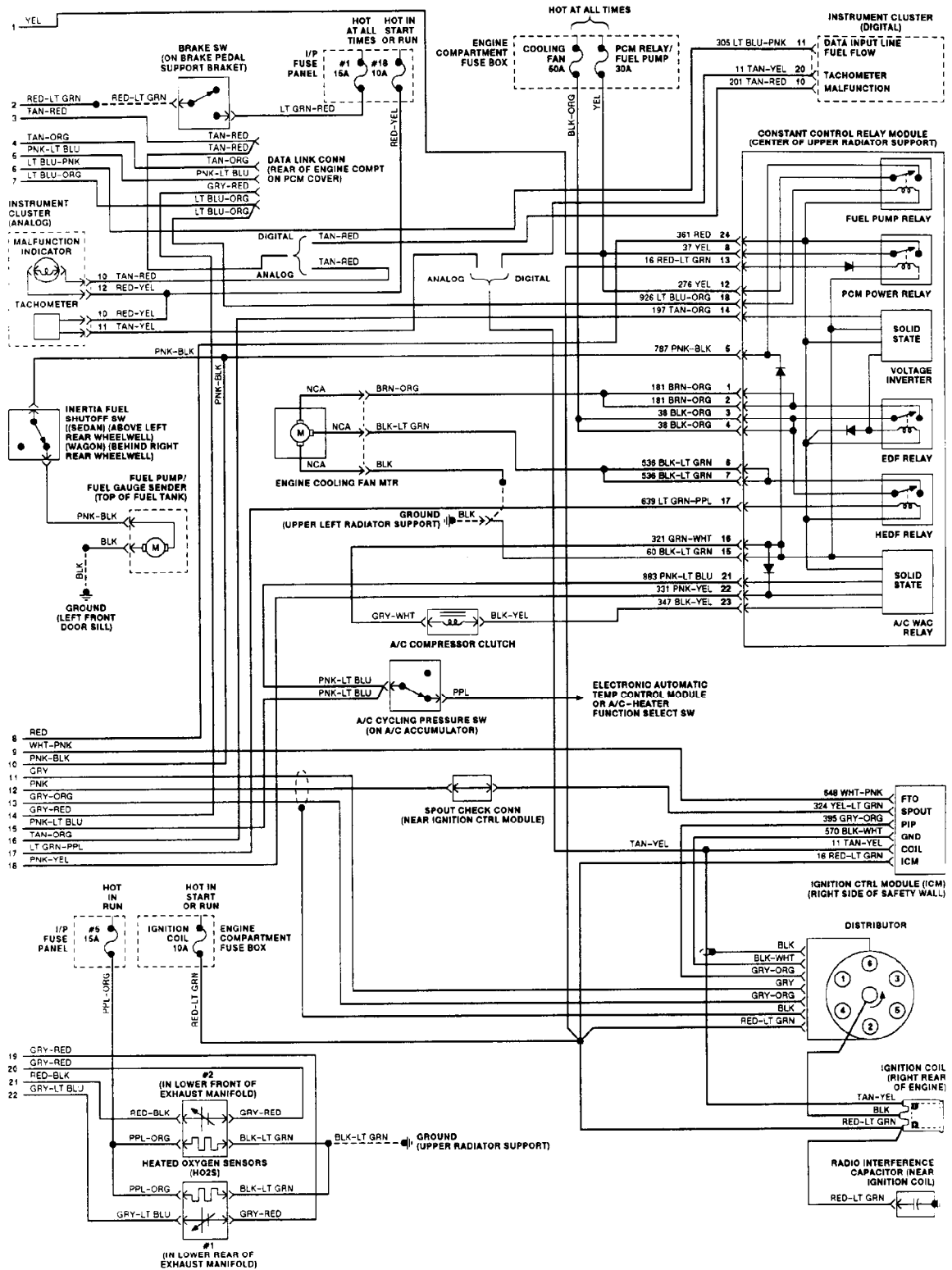

93E40661

Fig. 21: EEC-IV Wiring Diagram (3.8L - 2 of 2)

3.0L TAURUS - FLEX FUEL

WIRING DIAGRAMS

Selected Block (p. 5)

1993 Ford Taurus

For <http://www.mitchell.narod.ru/>

Copyright © 1997 Mitchell International

Friday, March 02, 2001 02:28PM

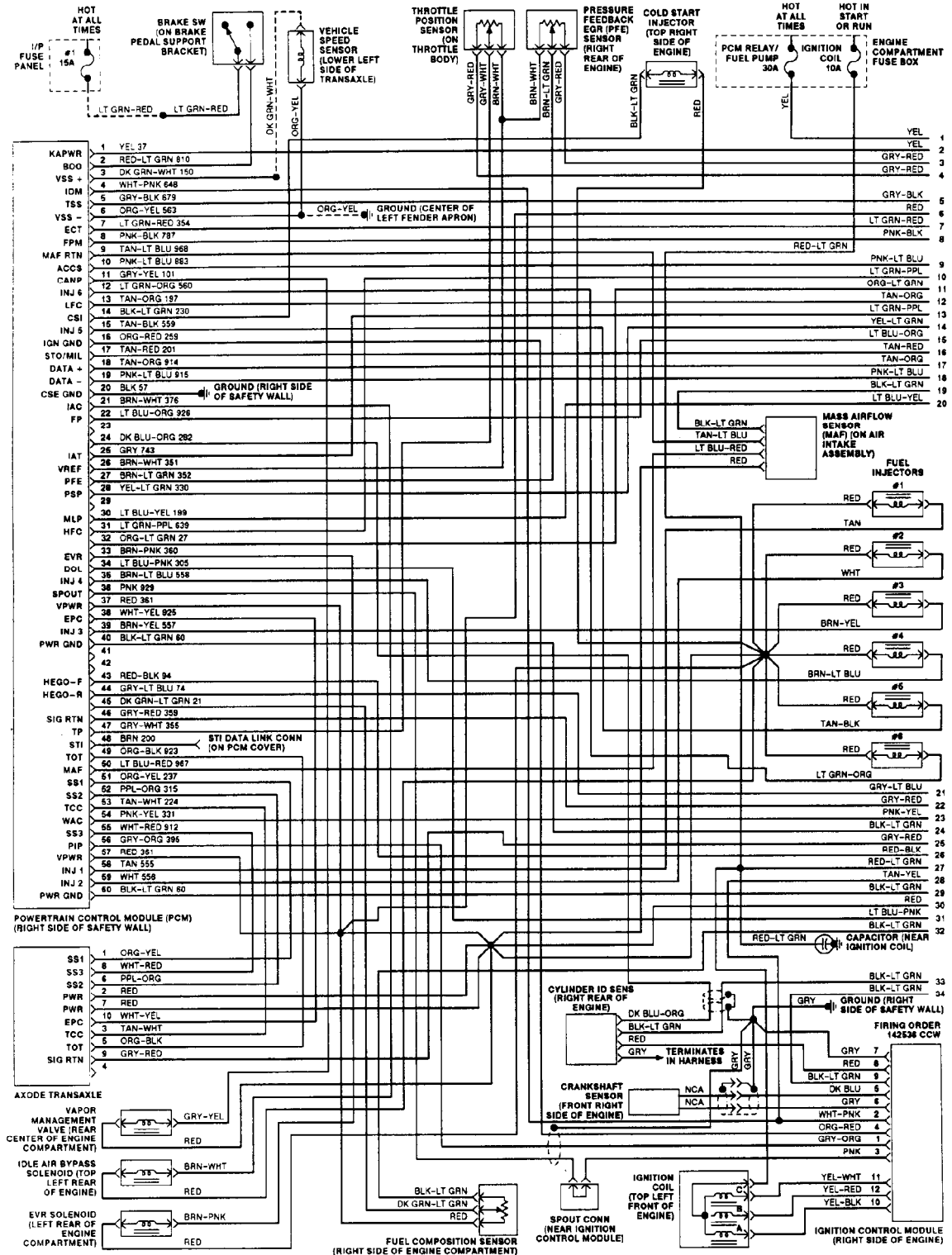

93F40662

Fig. 22: EEC-IV Wiring Diagram (3.0L Flex Fuel - 1 of 2)

WIRING DIAGRAMS

Selected Block (p. 6)

1993 Ford Taurus

For <http://www.mitchell.narod.ru/>

Copyright © 1997 Mitchell International

Friday, March 02, 2001 02:28PM

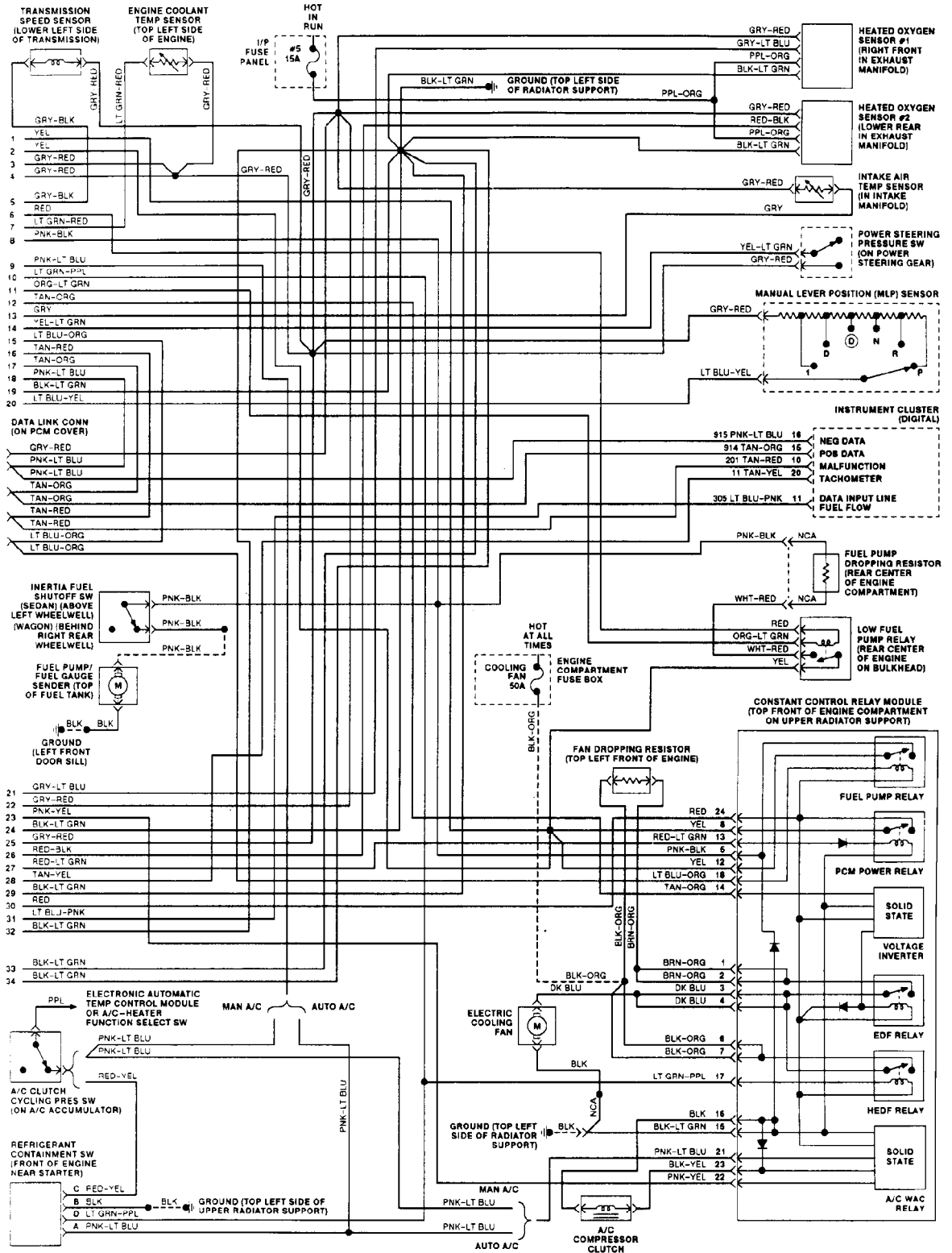

93G40663

Fig. 23: EEC-IV Wiring Diagram (3.0L Flex Fuel - 2 of 2)