

**WIRING DIAGRAMS**  
**Selected Block**  
 1993 Ford Taurus  
 For <http://www.mitchell.narod.ru/>  
 Copyright © 1997 Mitchell International  
 Friday, March 02, 2001 02:30PM

**POWER ANTENNAS**

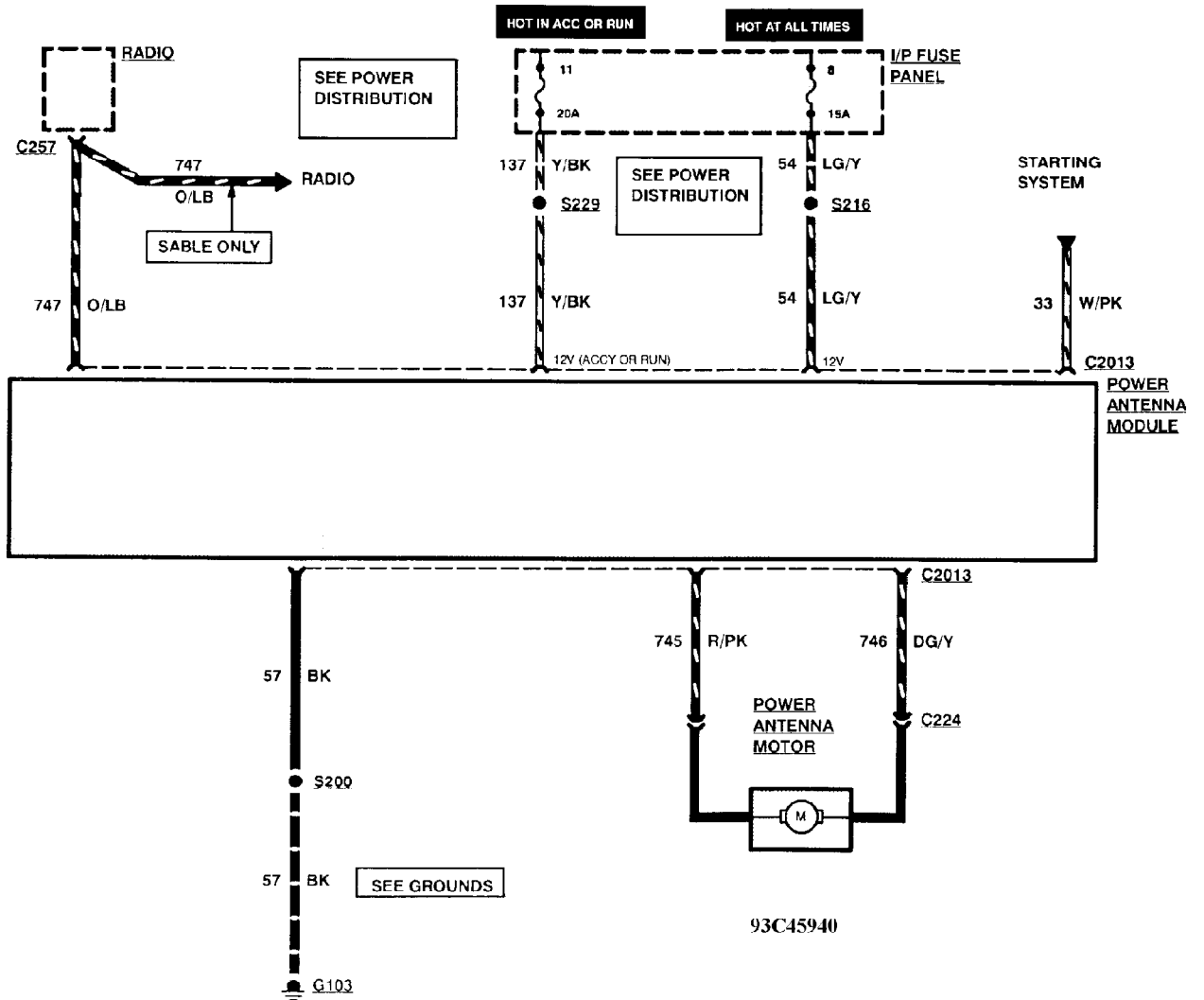

Fig. 73: Power Antenna Wiring Diagram

**POWER DOOR LOCKS & TRUNK RELEASE**

# WIRING DIAGRAMS

## Selected Block (p. 2)

1993 Ford Taurus

For <http://www.mitchell.narod.ru/>

Copyright © 1997 Mitchell International

Friday, March 02, 2001 02:30PM

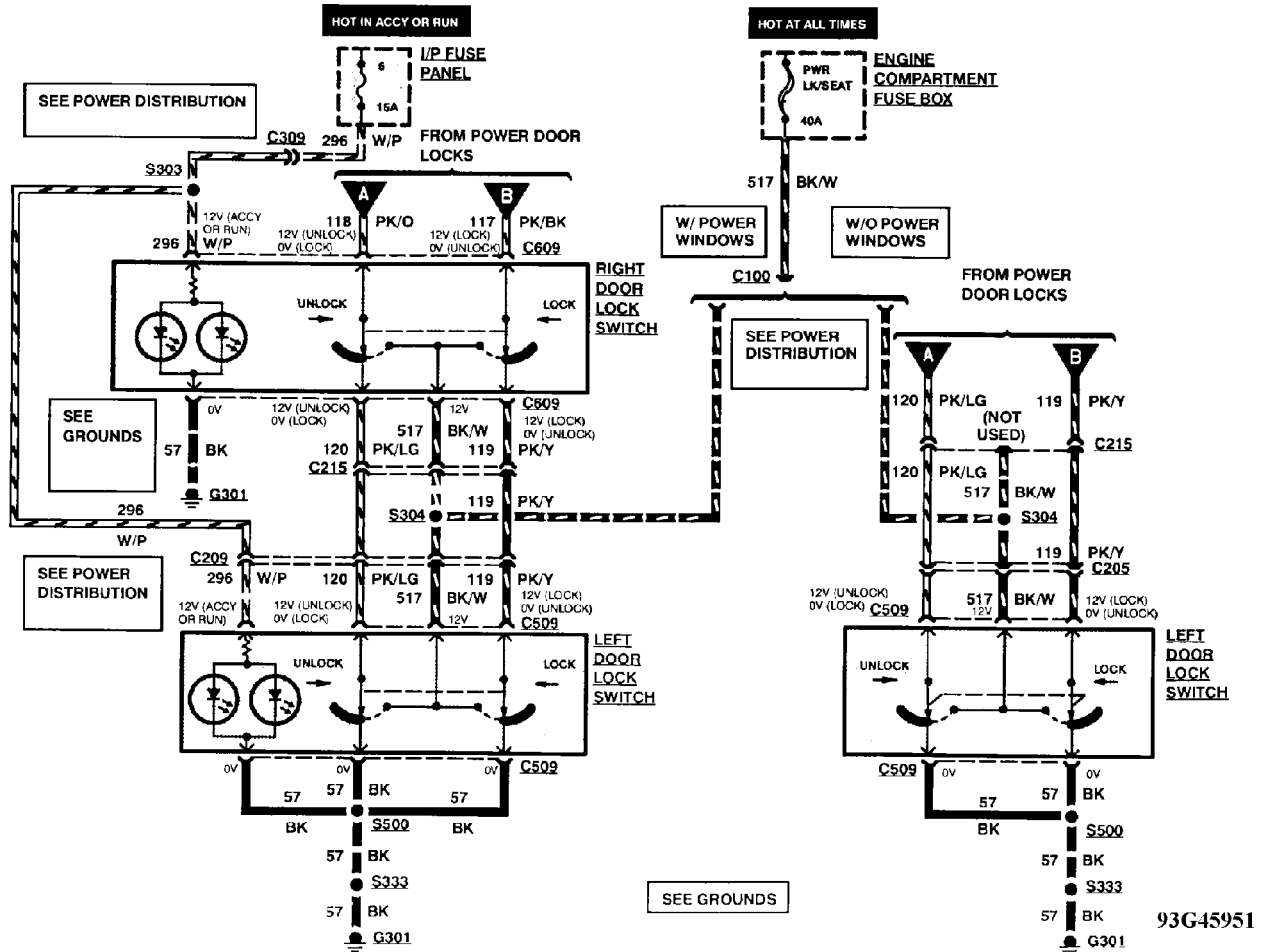

Fig. 74: Power Door Locks Wiring Diagram (1 Of 2)

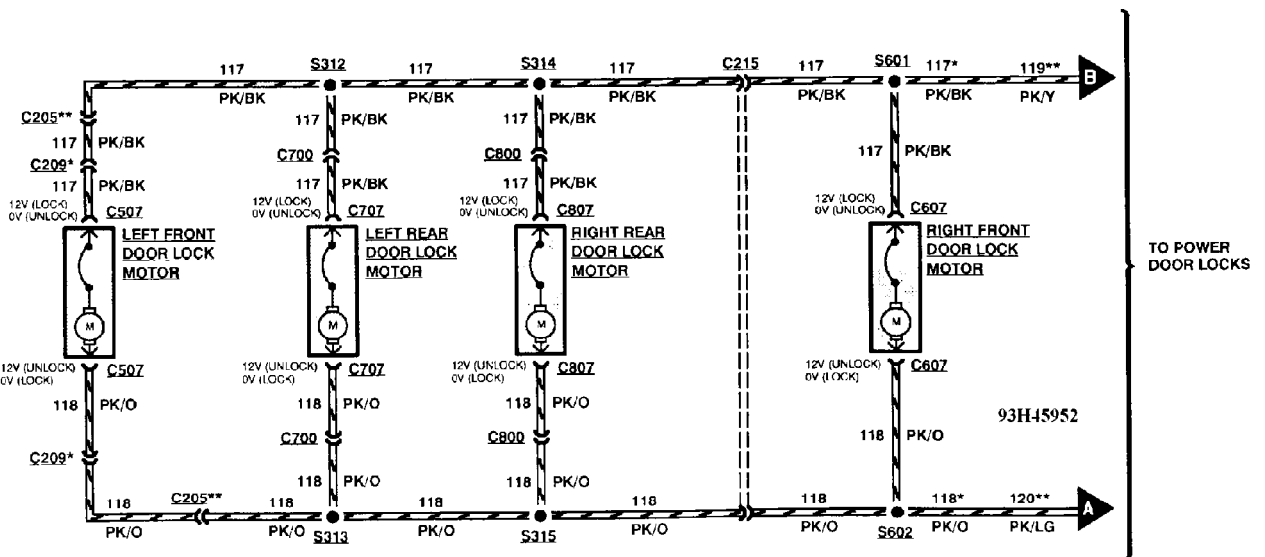

Fig. 75: Power Door Locks Wiring Diagram (2 Of 2)

### POWER MIRRORS

# WIRING DIAGRAMS

## Selected Block (p. 3)

1993 Ford Taurus

For <http://www.mitchell.narod.ru/>

Copyright © 1997 Mitchell International

Friday, March 02, 2001 02:30PM

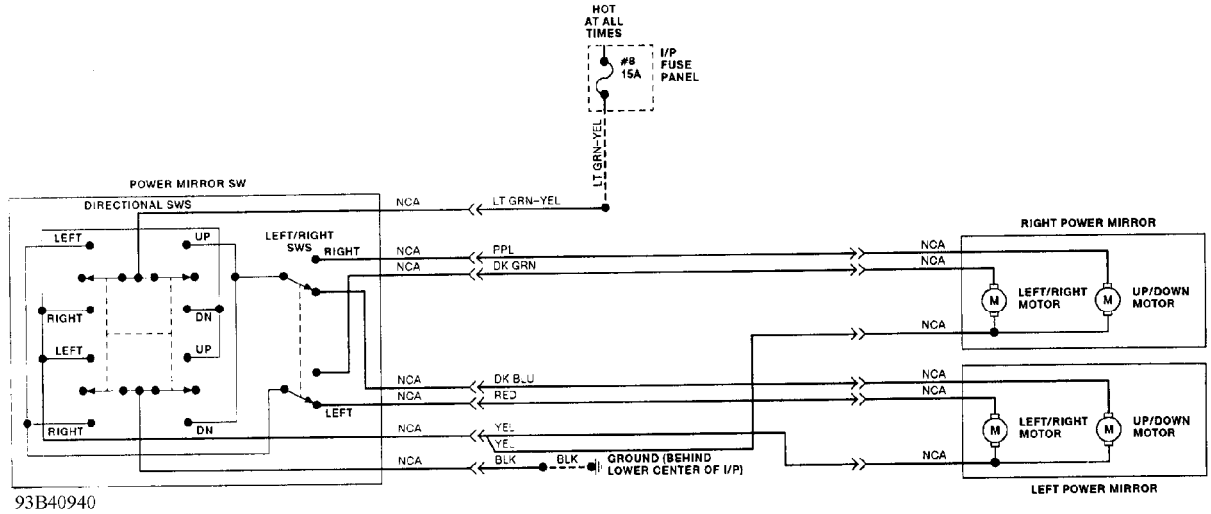

Fig. 76: Power Mirror System Wiring Diagram

## POWER MOON ROOFS

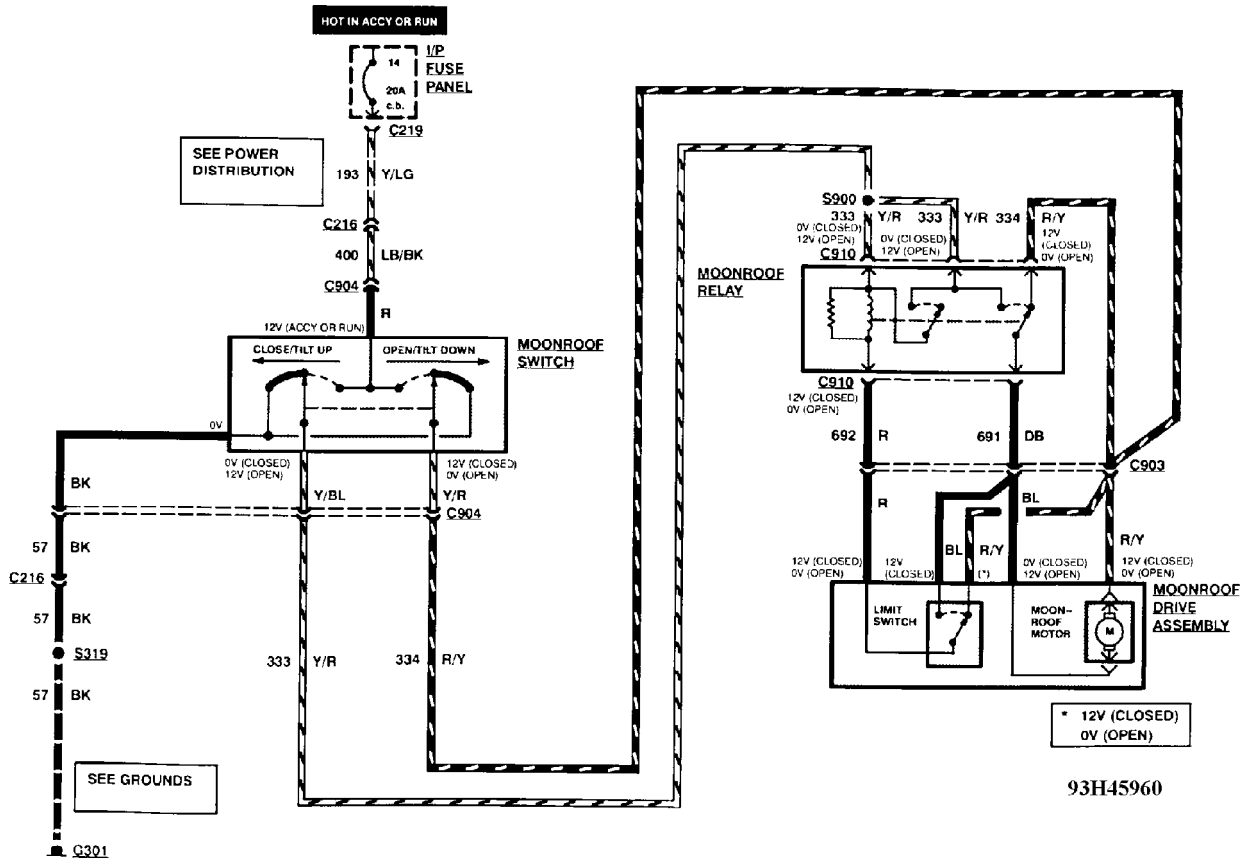

Fig. 77: Power Moon Roof Wiring Diagram