

WIRING DIAGRAMS
Selected Block
 1993 Ford Taurus
 For <http://www.mitchell.narod.ru/>
 Copyright © 1997 Mitchell International
 Friday, March 02, 2001 02:31PM

AUTOMATIC A/C-HEATER SYSTEMS

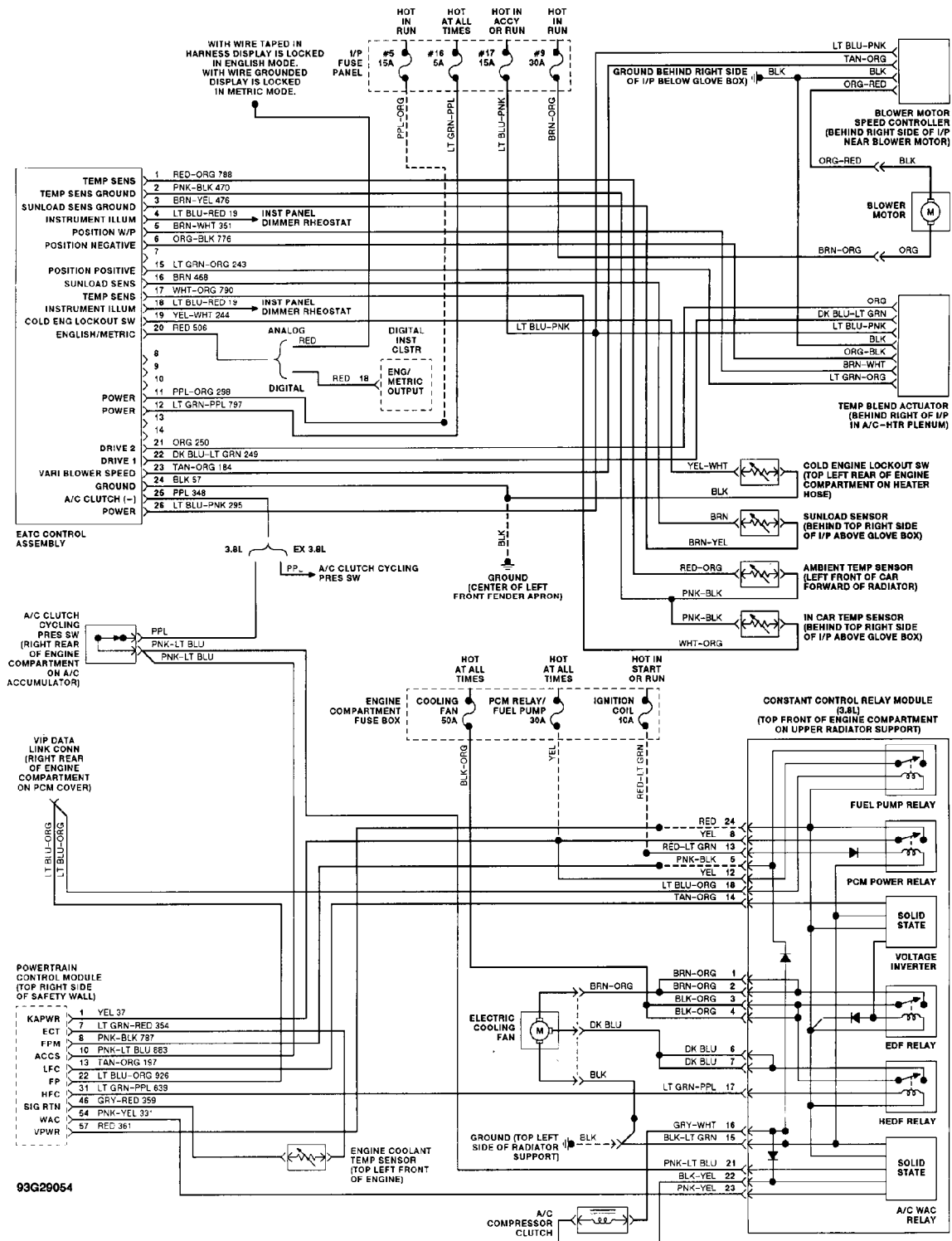

Fig. 94: Auto A/C-Heater Sys Wiring Diagram (1 Of 4)

WIRING DIAGRAMS

Selected Block (p. 2)

1993 Ford Taurus

For <http://www.mitchell.narod.ru/>

Copyright © 1997 Mitchell International

Friday, March 02, 2001 02:31PM

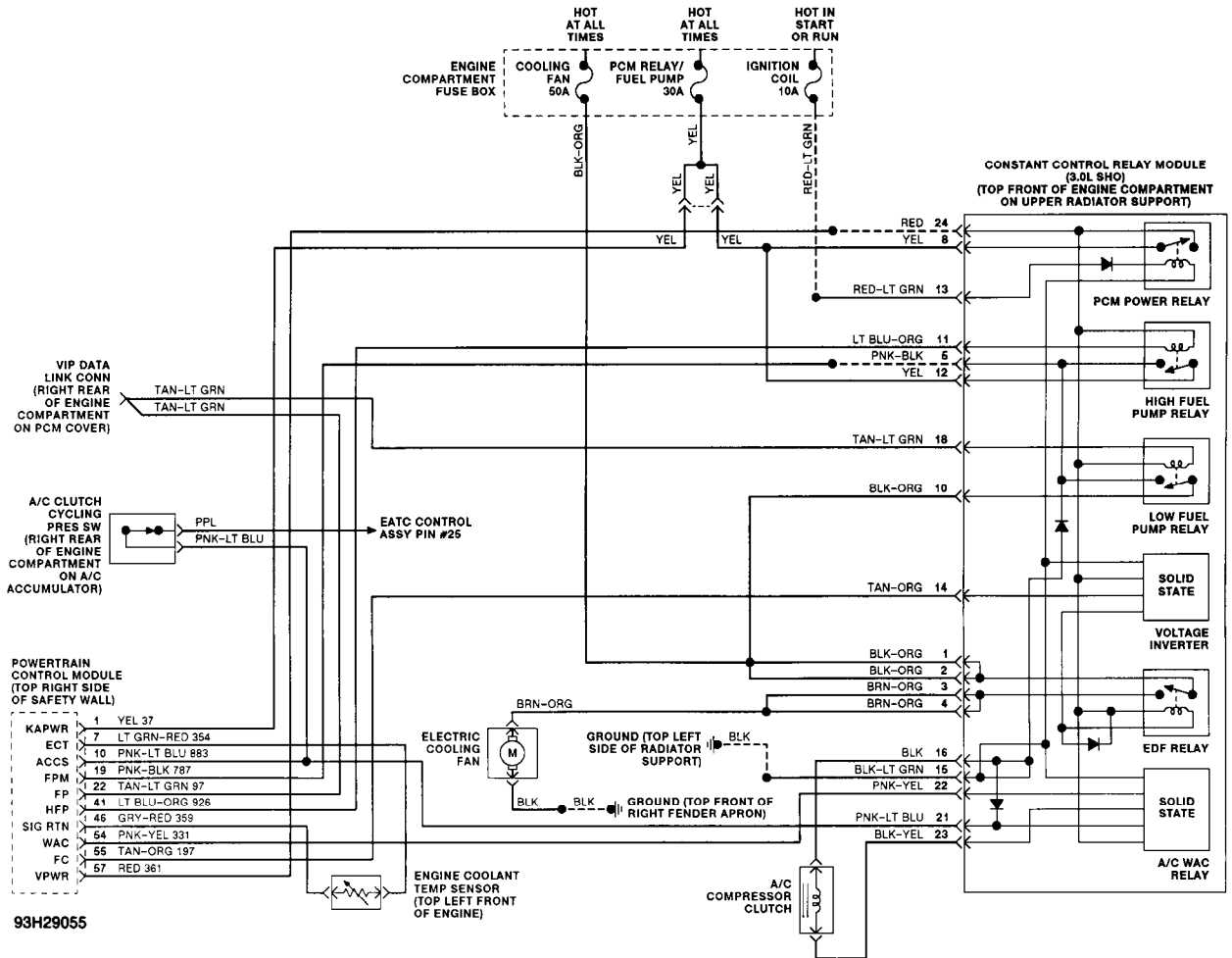

Fig. 95: Auto A/C-Heater Sys Wiring Diagram (2 Of 4)

WIRING DIAGRAMS

Selected Block (p. 3)

1993 Ford Taurus

For <http://www.mitchell.narod.ru/>

Copyright © 1997 Mitchell International

Friday, March 02, 2001 02:31PM

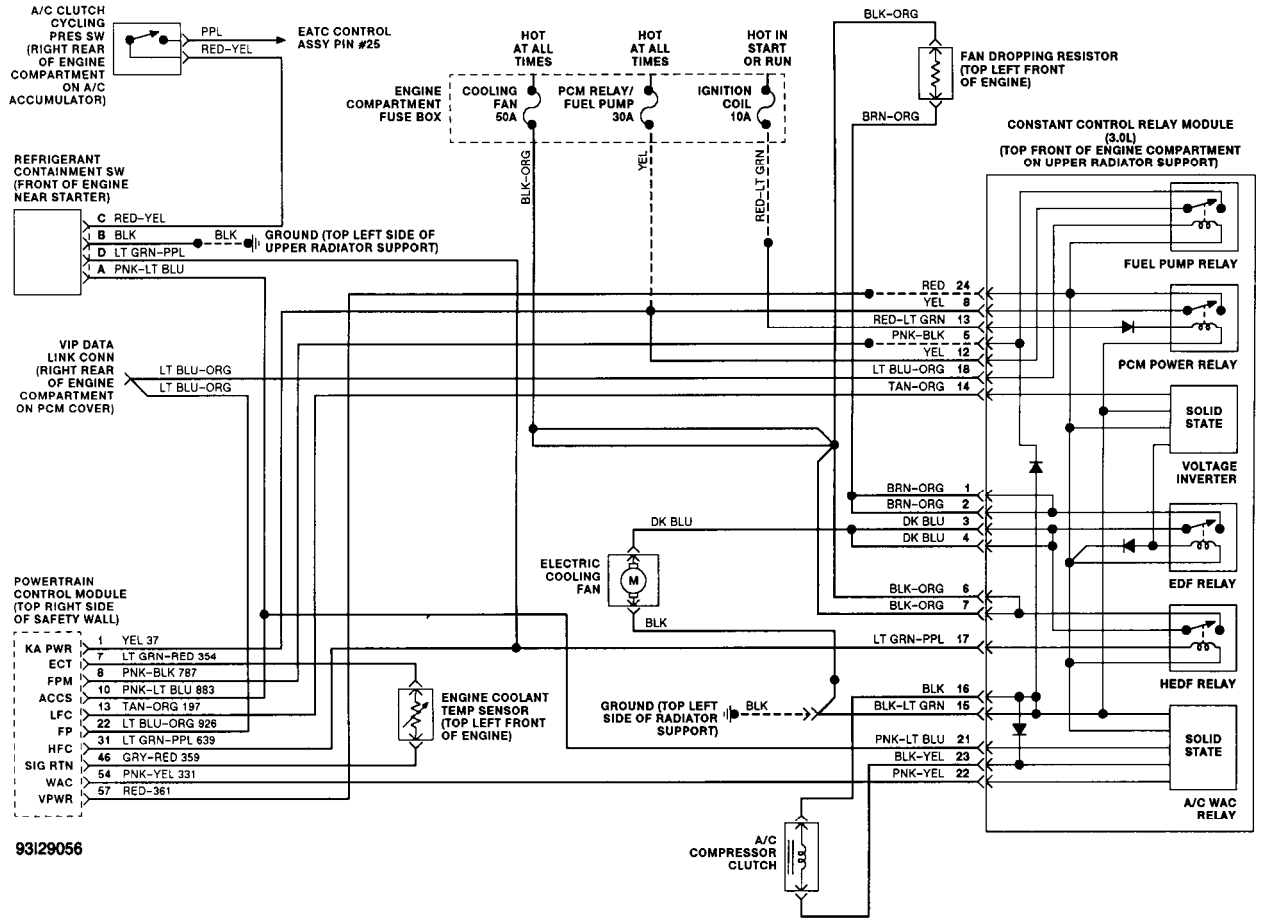

Fig. 96: Auto A/C-Heater Sys Wiring Diagram (3 Of 4)

WIRING DIAGRAMS

Selected Block (p. 4)

1993 Ford Taurus

For <http://www.mitchell.narod.ru/>

Copyright © 1997 Mitchell International

Friday, March 02, 2001 02:31PM

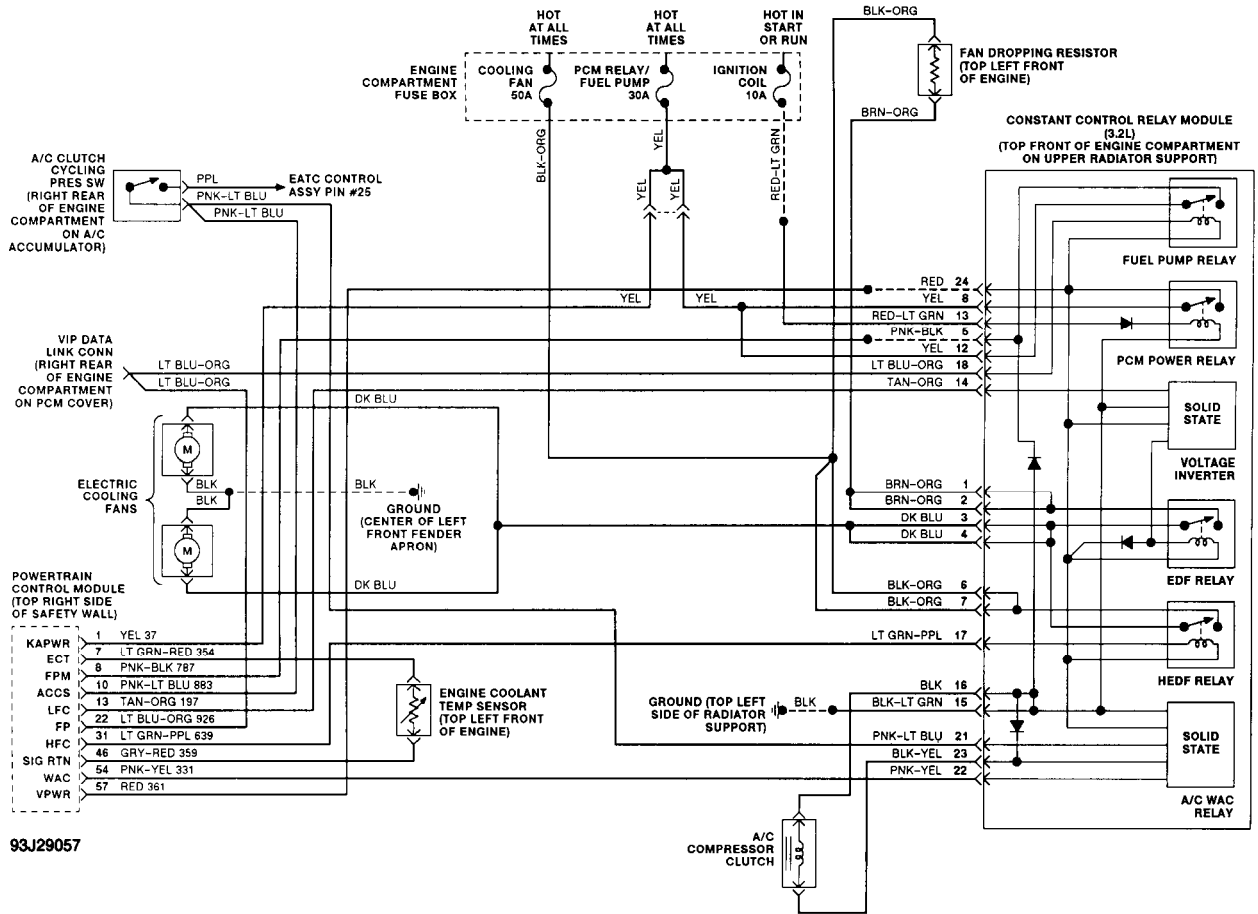

Fig. 97: Auto A/C-Heater Sys Wiring Diagram (4 Of 4)

HEATER SYSTEMS

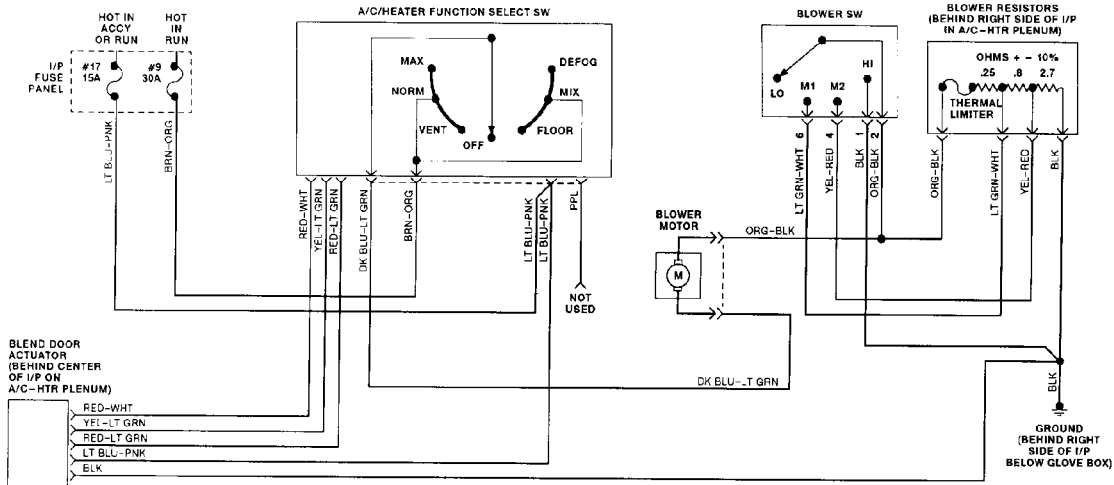

Fig. 98: Heater System Wiring Diagram

MANUAL A/C-HEATER SYSTEMS

WIRING DIAGRAMS

Selected Block (p. 5)

1993 Ford Taurus

For <http://www.mitchell.narod.ru/>

Copyright © 1997 Mitchell International

Friday, March 02, 2001 02:31PM

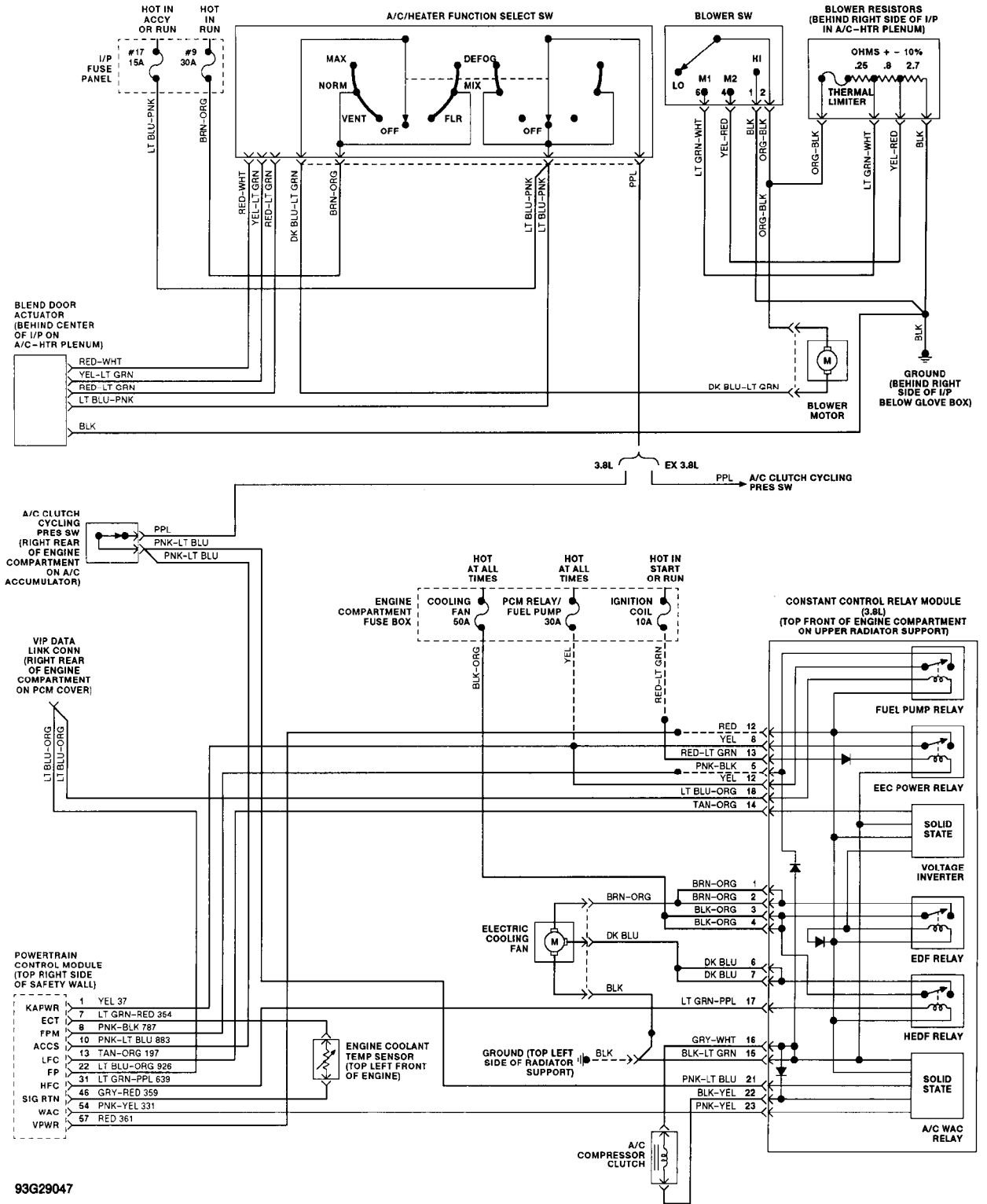

93G29047

Fig. 99: Man. A/C-Heater Sys. Wiring Diagram (1 Of 4)

WIRING DIAGRAMS

Selected Block (p. 6)

1993 Ford Taurus

For <http://www.mitchell.narod.ru/>

Copyright © 1997 Mitchell International

Friday, March 02, 2001 02:31PM

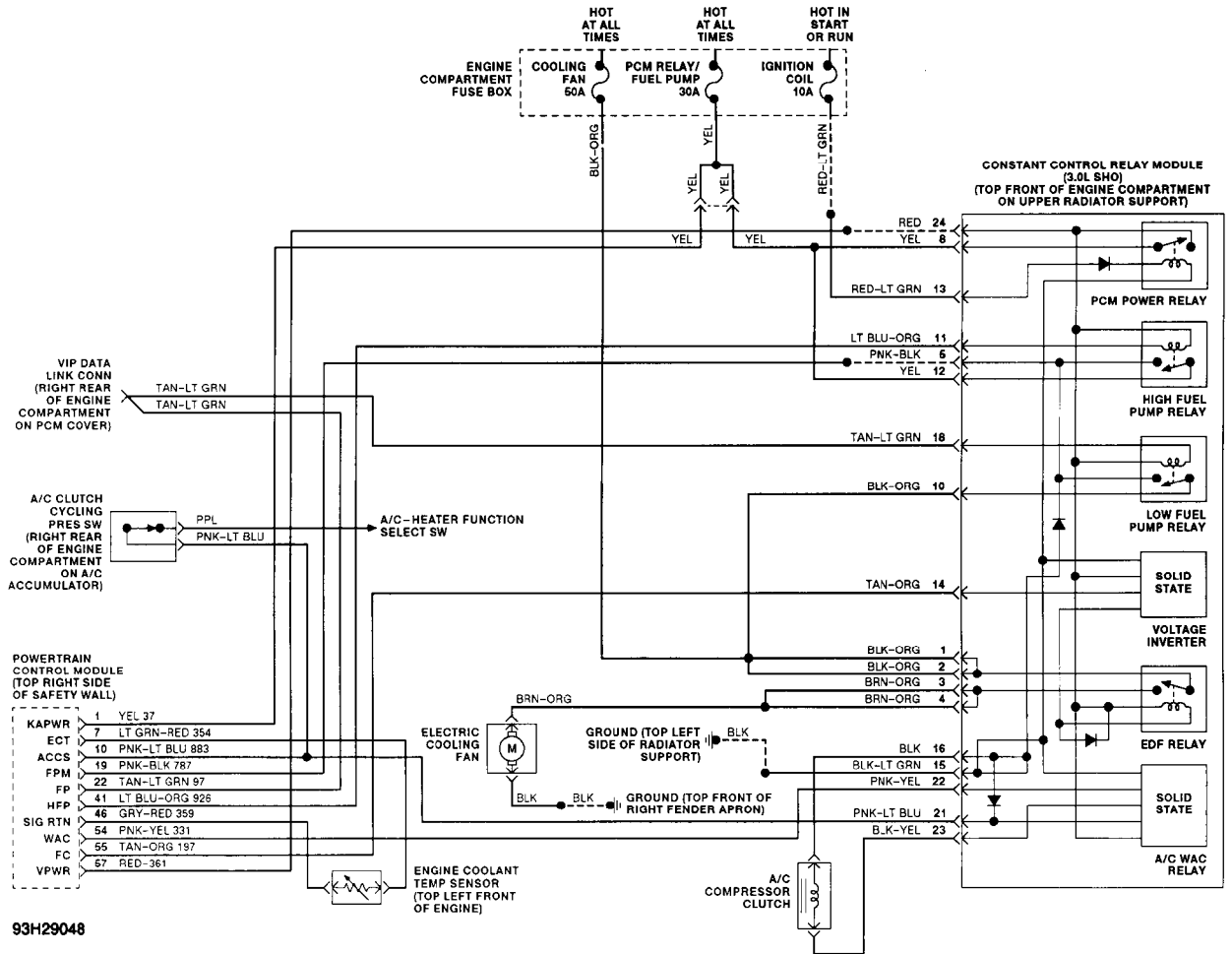

Fig. 100: Man. A/C-Heater Sys. Wiring Diagram (2 Of 4)

WIRING DIAGRAMS

Selected Block (p. 7)

1993 Ford Taurus

For <http://www.mitchell.narod.ru/>

Copyright © 1997 Mitchell International

Friday, March 02, 2001 02:31PM

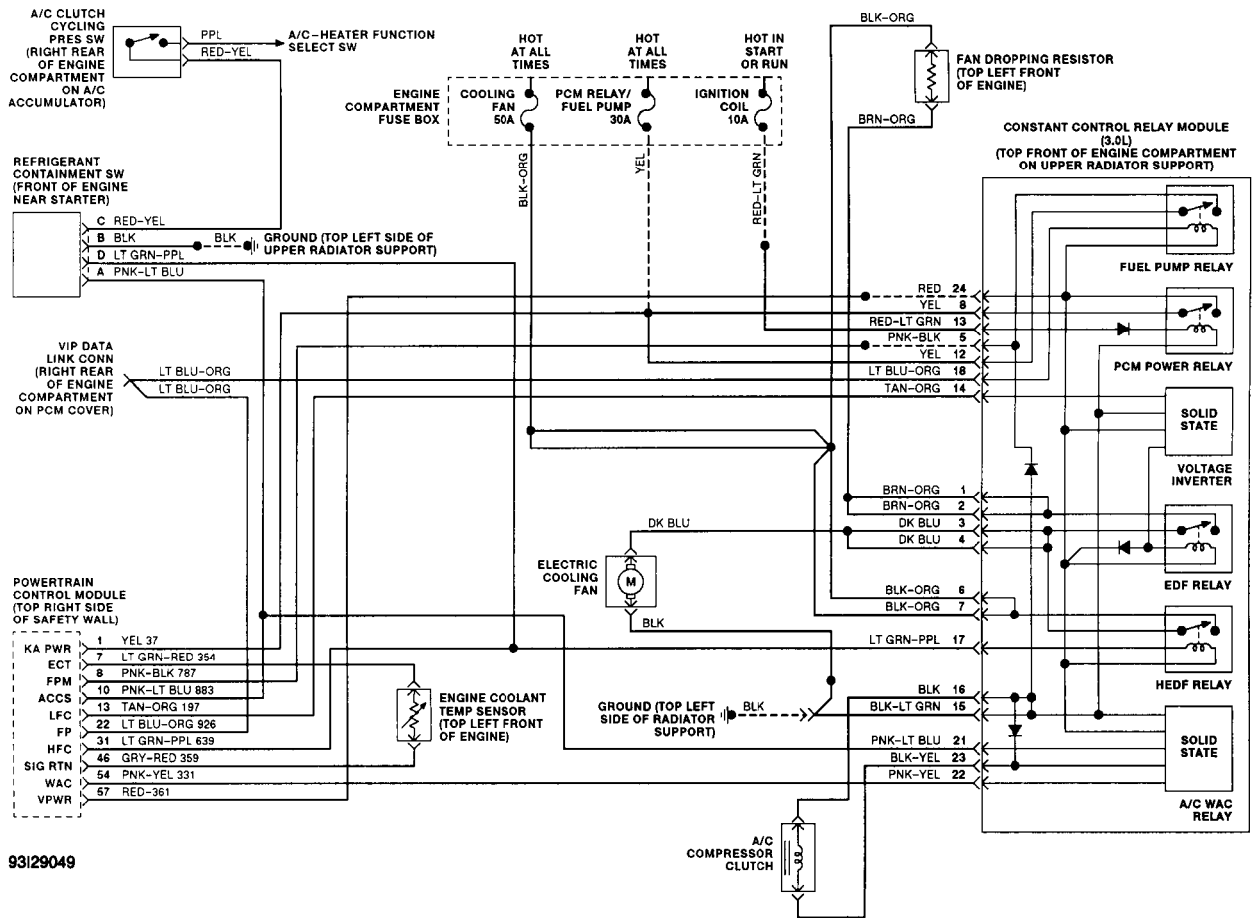

Fig. 101: Man. A/C-Heater Sys. Wiring Diagram (3 Of 4)

WIRING DIAGRAMS

Selected Block (p. 8)

1993 Ford Taurus

For <http://www.mitchell.narod.ru/>

Copyright © 1997 Mitchell International

Friday, March 02, 2001 02:31PM

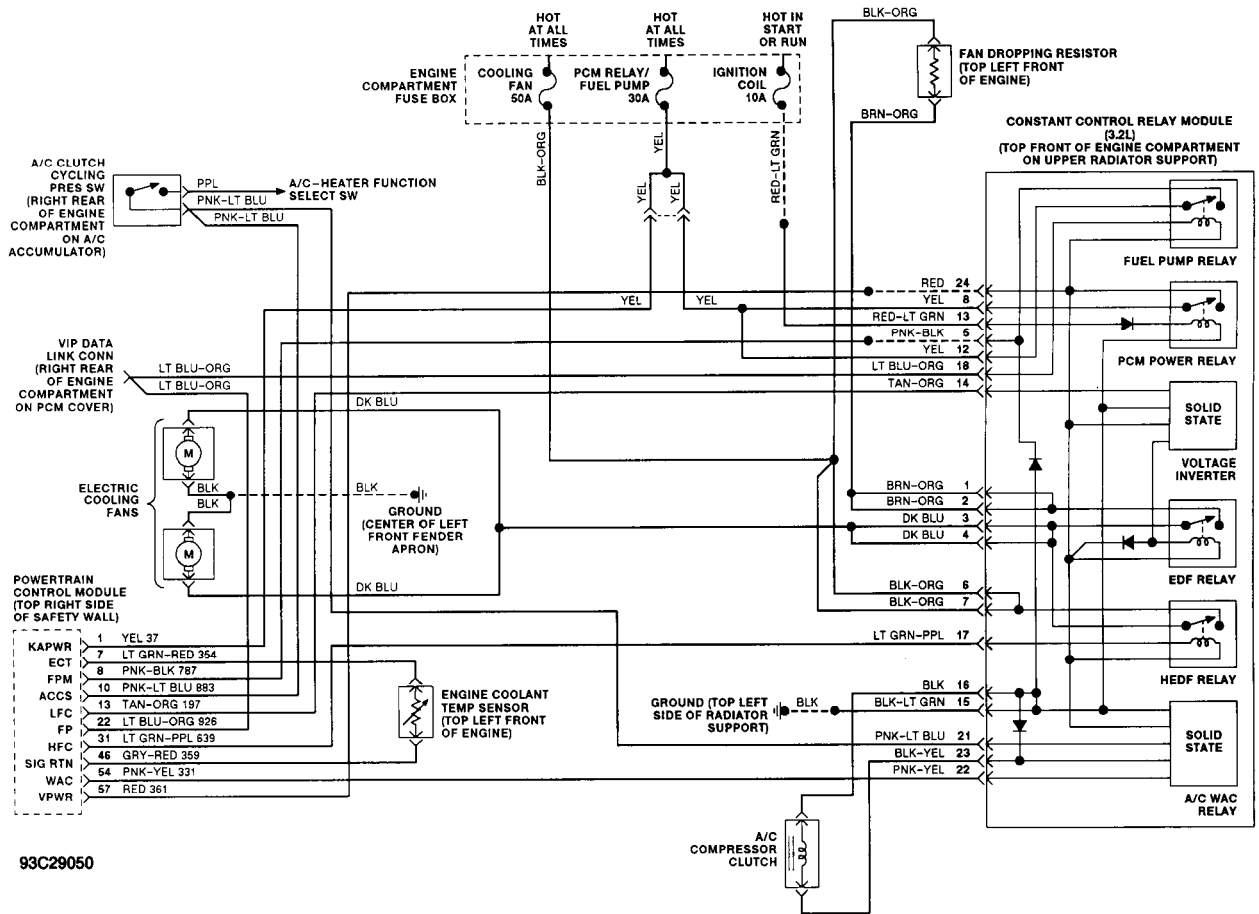

Fig. 102: Man. A/C-Heater Sys. Wiring Diagram (4 Of 4)