

WIRING DIAGRAMS
Selected Block
1993 Ford Taurus
For <http://www.mitchell.narod.ru/>
Copyright © 1997 Mitchell International
Friday, March 02, 2001 02:32PM

G - EEC-IV TESTS W/CODES

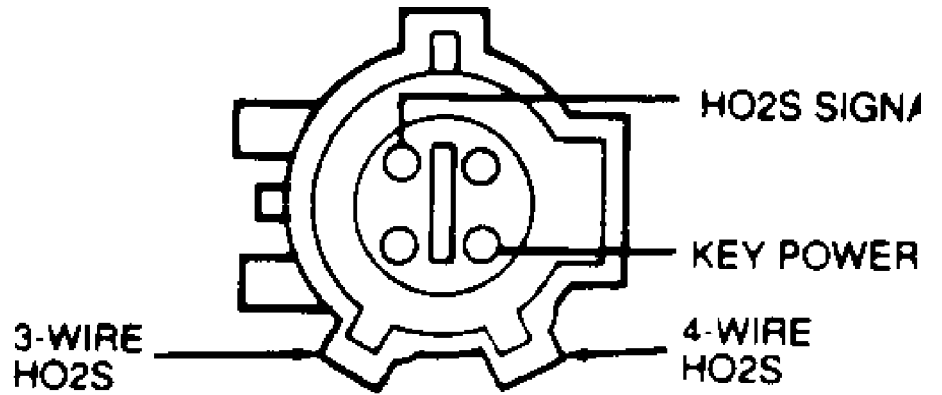

93B40619

Fig. 119: Identifying HO2S Sensor Wiring Harness Connector Terminals

WIRING DIAGRAMS

Selected Block (p. 2)

1993 Ford Taurus

For <http://www.mitchell.narod.ru/>

Copyright © 1997 Mitchell International

Friday, March 02, 2001 02:32PM

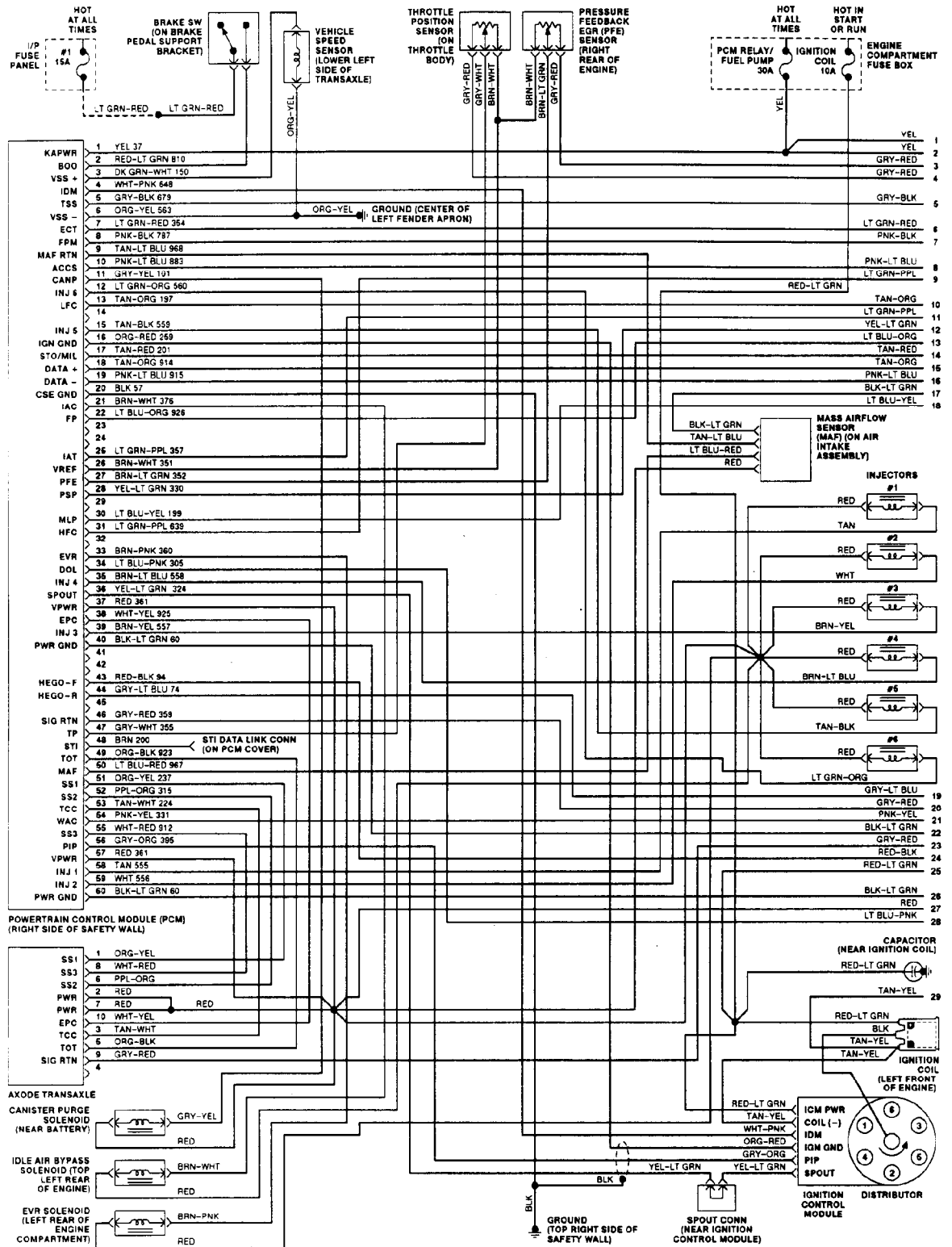

Fig. 120: EEC-IV Wiring Diagram (3.0L Except SHO 1 of 2)

WIRING DIAGRAMS

Selected Block (p. 3)

1993 Ford Taurus

For <http://www.mitchell.narod.ru/>

Copyright © 1997 Mitchell International

Friday, March 02, 2001 02:32PM

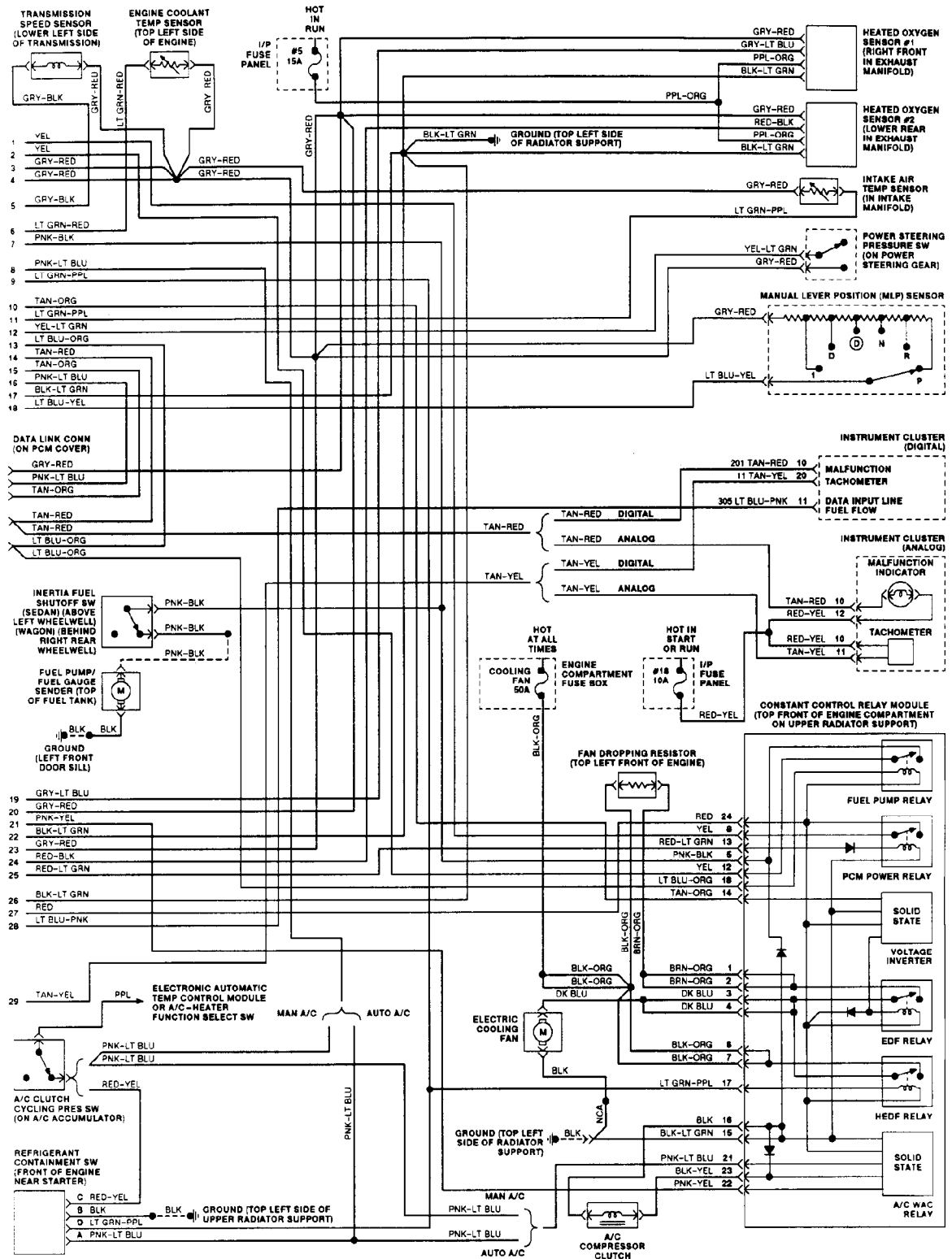

93A40659

Fig. 121: EEC-IV Wiring Diagram (3.0L Except SHO 2 of 2)

WIRING DIAGRAMS

Selected Block (p. 4)

1993 Ford Taurus

For <http://www.mitchell.narod.ru/>

Copyright © 1997 Mitchell International

Friday, March 02, 2001 02:32PM

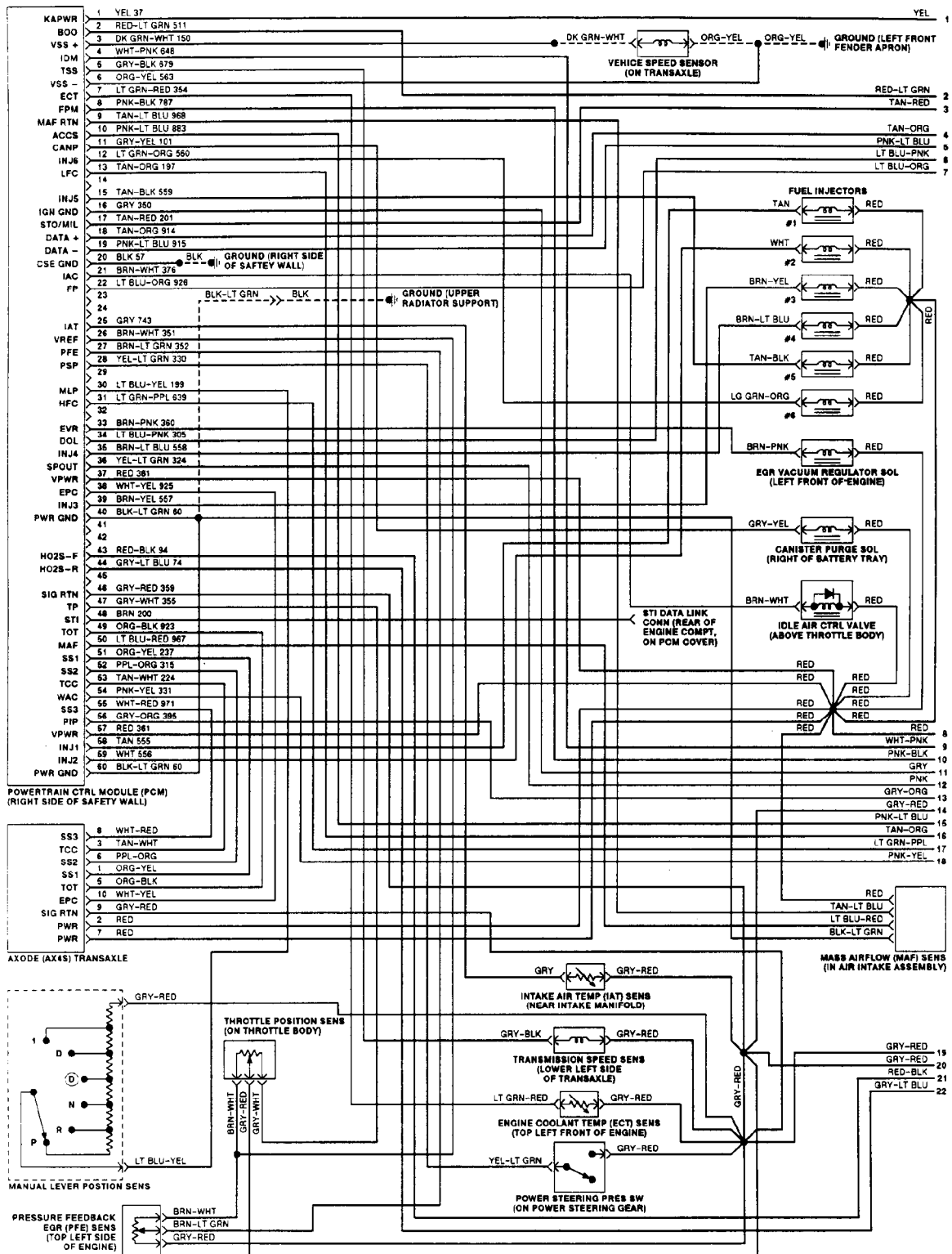

93D40680

Fig. 122: EEC-IV Wiring Diagram (3.8L - 1 of 2)

WIRING DIAGRAMS

Selected Block (p. 5)

1993 Ford Taurus

For <http://www.mitchell.narod.ru/>

Copyright © 1997 Mitchell International

Friday, March 02, 2001 02:32PM

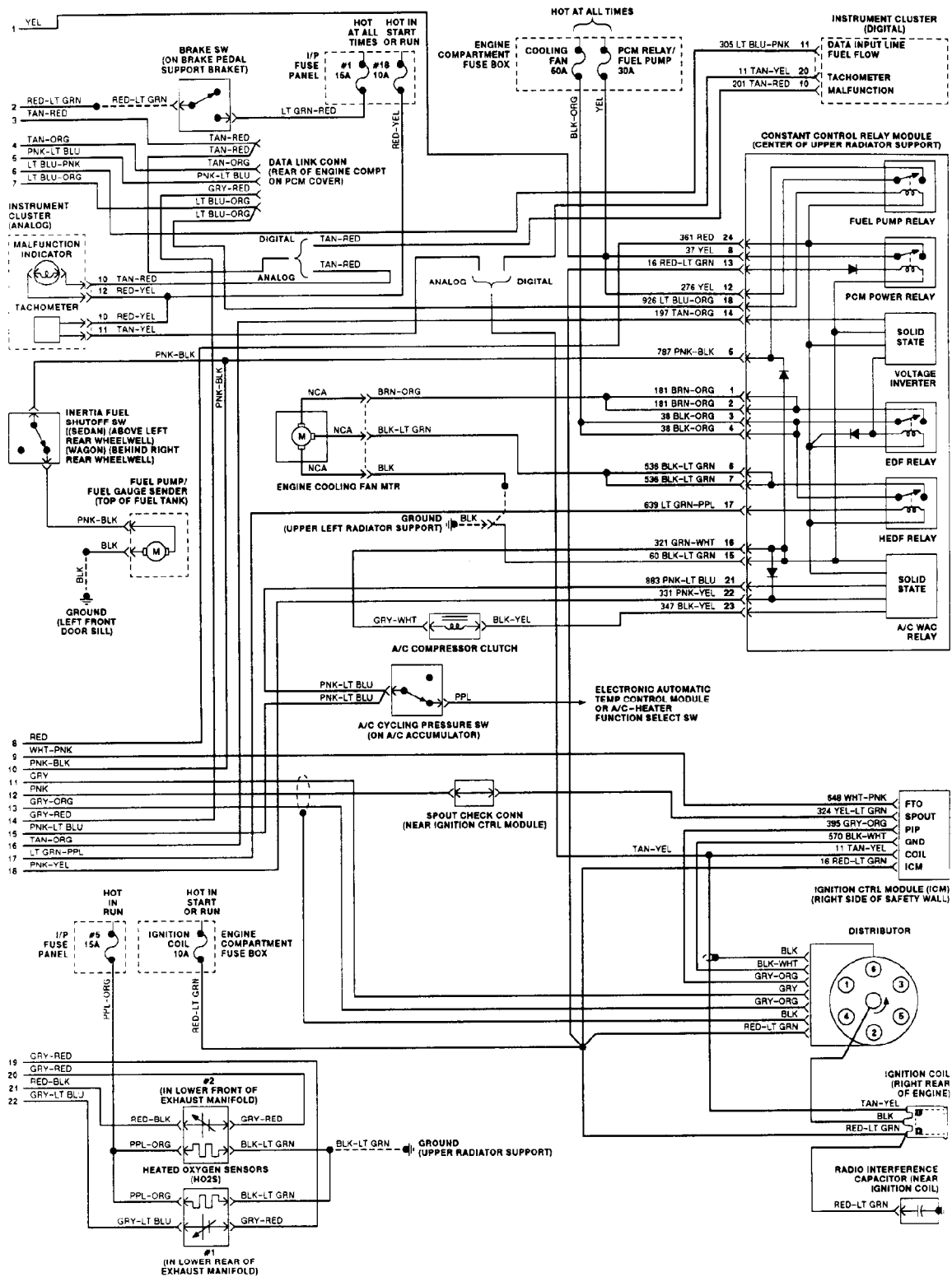

93E40661

Fig. 123: EEC-IV Wiring Diagram (3.8L - 2 of 2)

WIRING DIAGRAMS

Selected Block (p. 6)

1993 Ford Taurus

For <http://www.mitchell.narod.ru/>

Copyright © 1997 Mitchell International

Friday, March 02, 2001 02:32PM

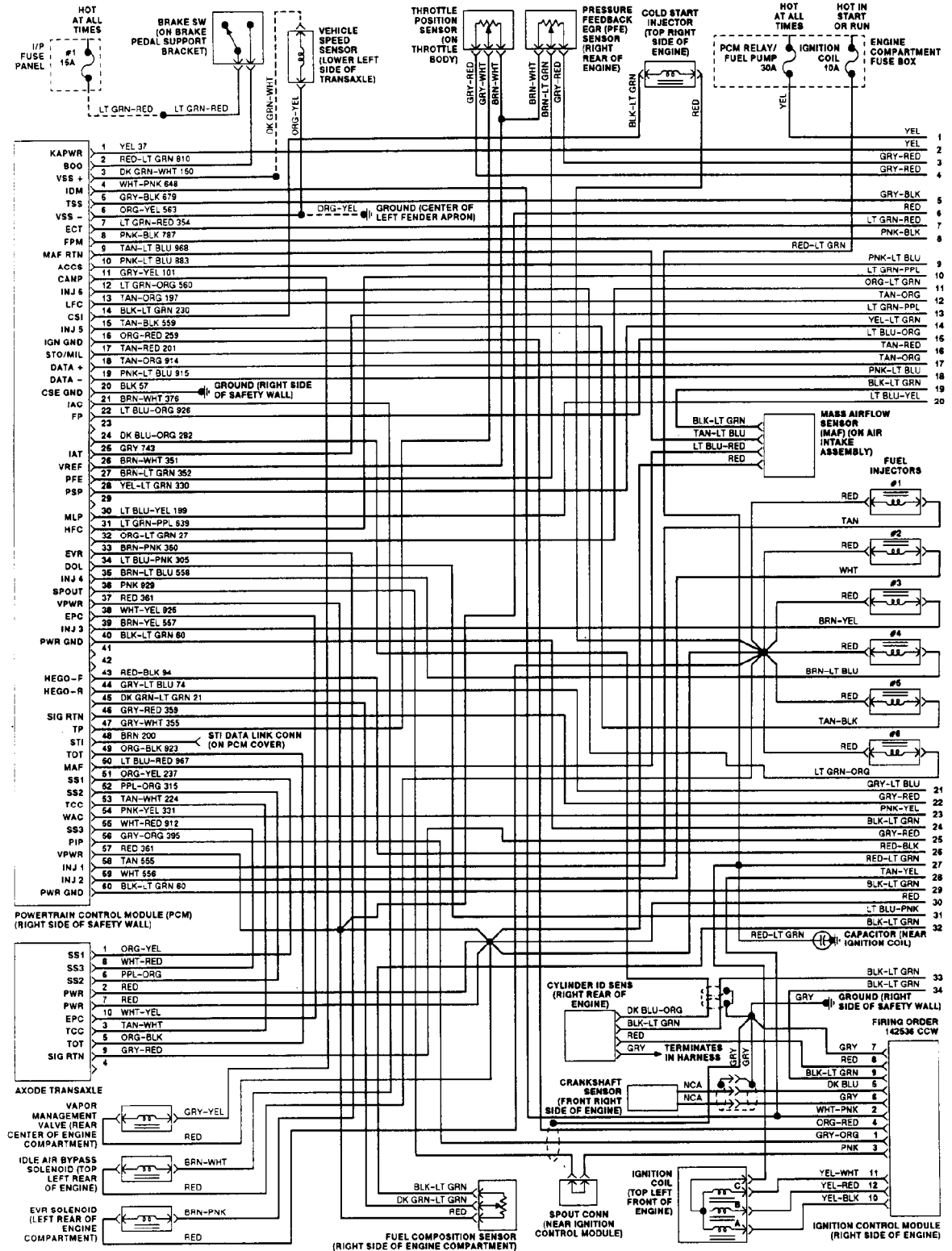

Fig. 124: EEC-IV Wiring Diagram (3.0L Flex Fuel - 1 of 2)

WIRING DIAGRAMS

Selected Block (p. 7)

1993 Ford Taurus

For <http://www.mitchell.narod.ru/>

Copyright © 1997 Mitchell International

Friday, March 02, 2001 02:32PM

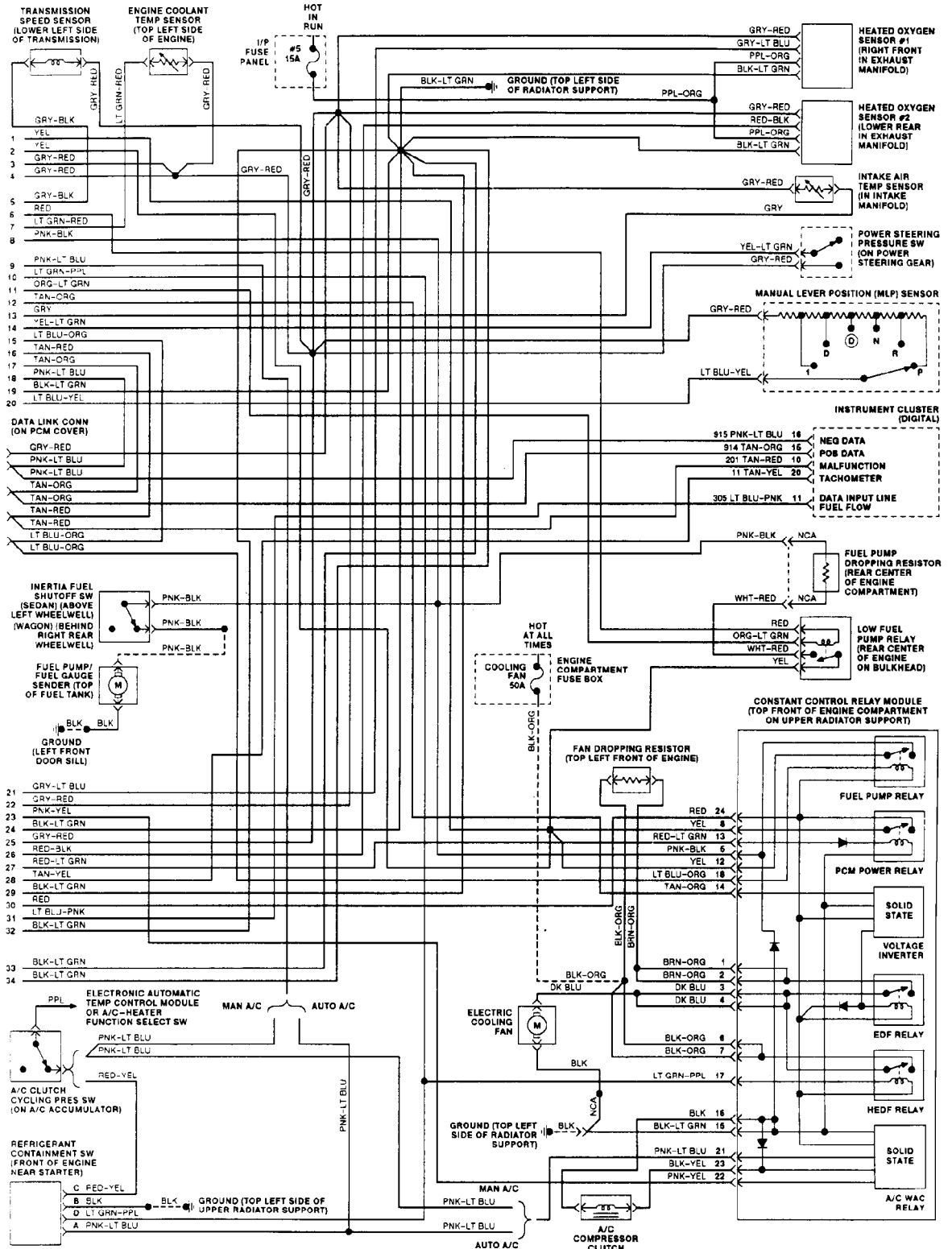

93G40663

Fig. 125: EEC-IV Wiring Diagram (3.0L Flex Fuel - 2 of 2)

WIRING DIAGRAMS

Selected Block (p. 8)

1993 Ford Taurus

For <http://www.mitchell.narod.ru/>

Copyright © 1997 Mitchell International

Friday, March 02, 2001 02:32PM

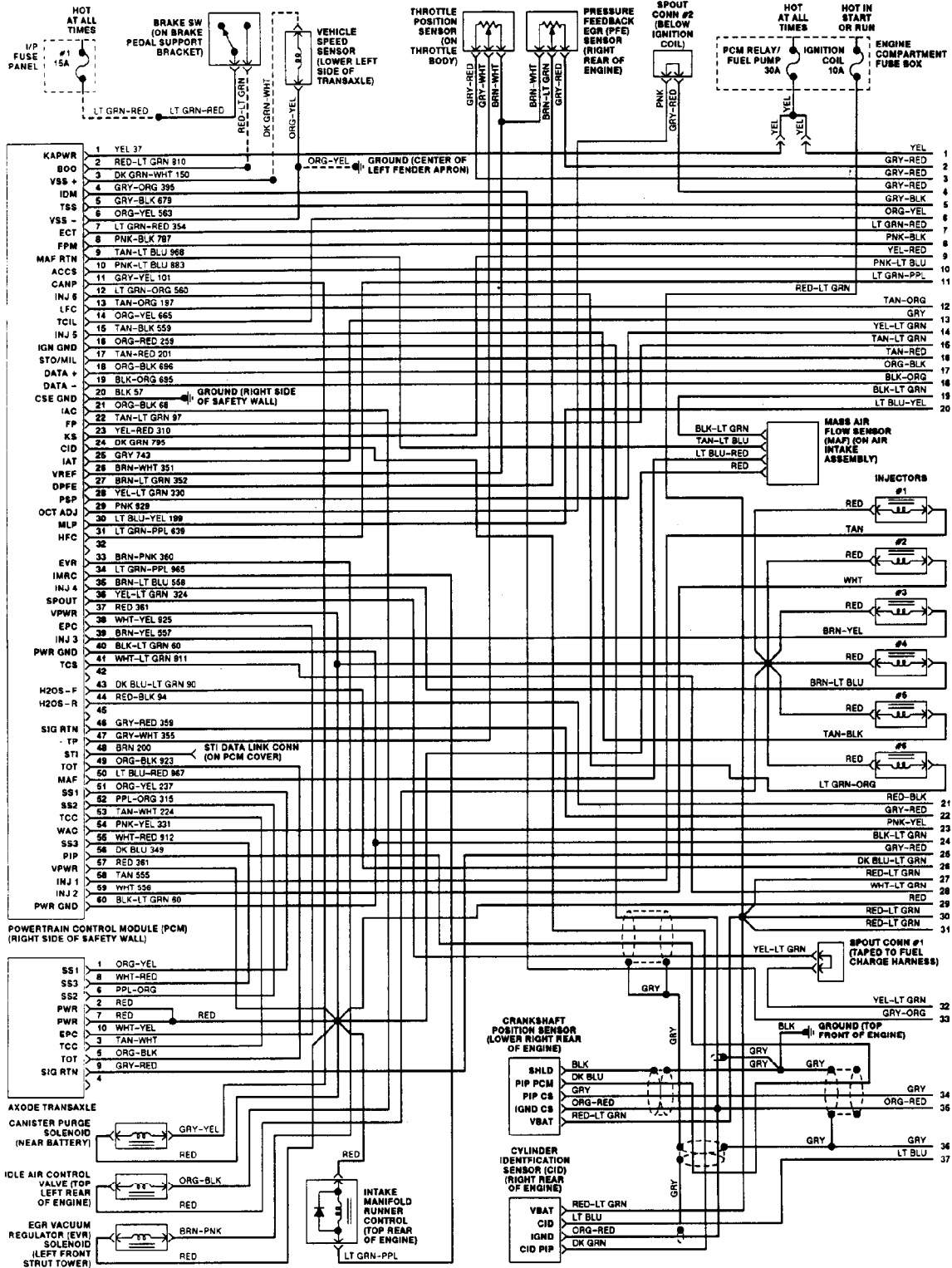

93J40666

Fig. 126: EEC-IV Wiring Diagram (3.2L SHO - 1 of 2)

WIRING DIAGRAMS

Selected Block (p. 9)

1993 Ford Taurus

For <http://www.mitchell.narod.ru/>

Copyright © 1997 Mitchell International

Friday, March 02, 2001 02:32PM

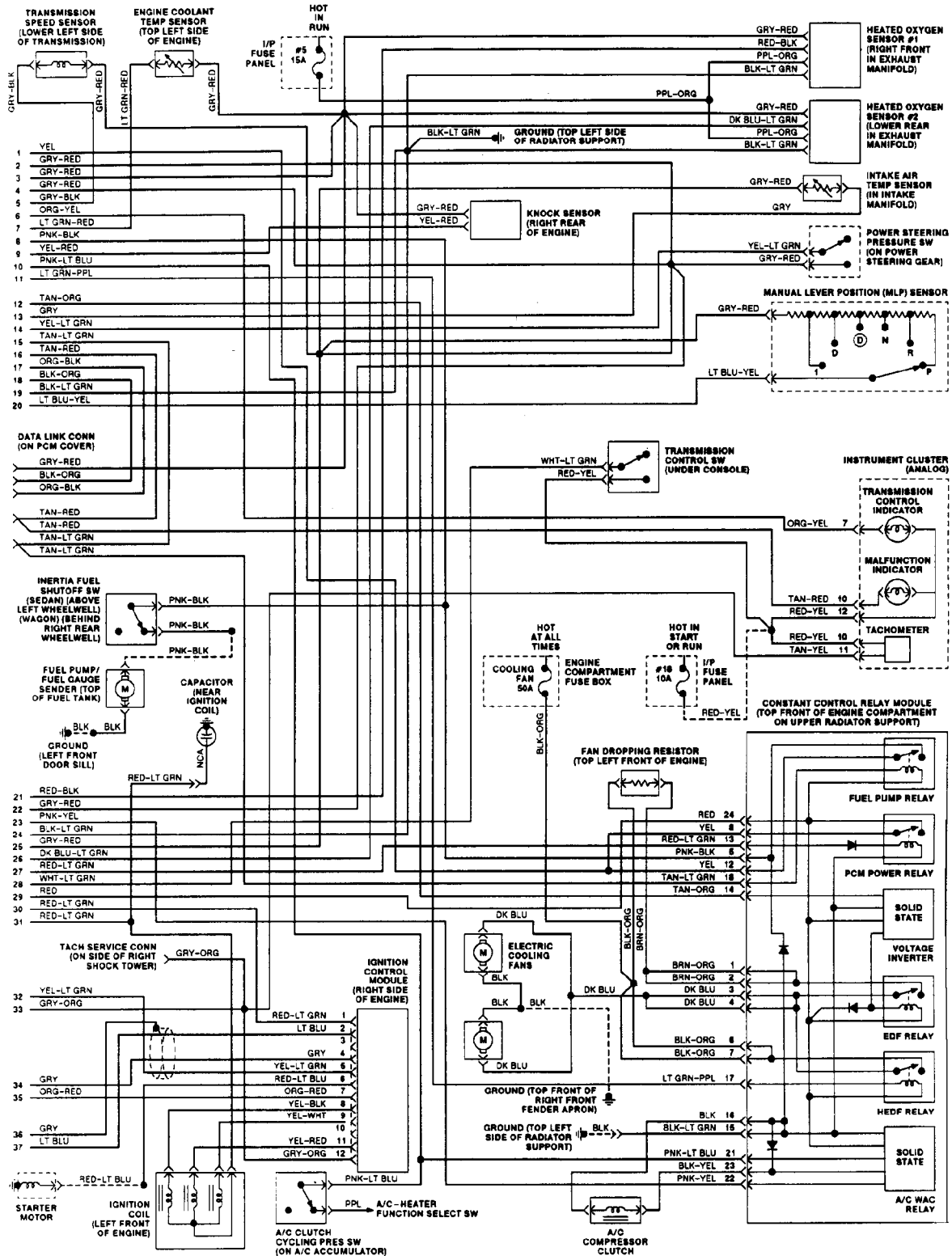

93A40667

Fig. 127: EEC-IV Wiring Diagram (3.2L SHO - 2 of 2)

WIRING DIAGRAMS
Selected Block (p. 10)

1993 Ford Taurus

For <http://www.mitchell.narod.ru/>
 Copyright © 1997 Mitchell International
 Friday, March 02, 2001 02:32PM

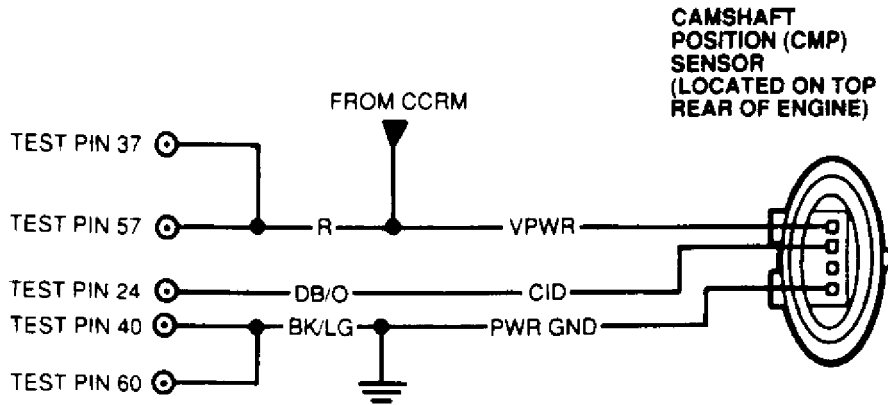

*TEST PINS LOCATED ON BREAKOUT BOX.
 ALL HARNESS CONNECTORS VIEWED IN MATING SURFACE.

93A40535

Fig. 128: CID Wiring Harness Circuits (3.0L Flexible Fuel)

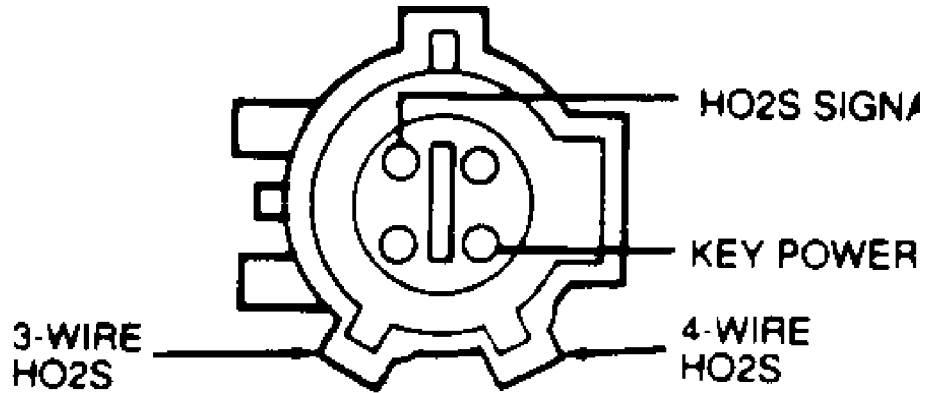

93B40619

Fig. 129: HO2S Sensor Wiring Harness Connector

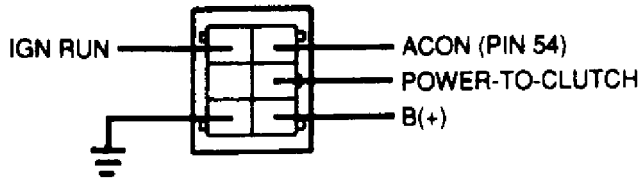

93G40754

Fig. 130: Identifying A/C Relay Wiring Harness Connector Terminals

WIRING DIAGRAMS
Selected Block (p. 11)

1993 Ford Taurus

For <http://www.mitchell.narod.ru/>
Copyright © 1997 Mitchell International
Friday, March 02, 2001 02:32PM

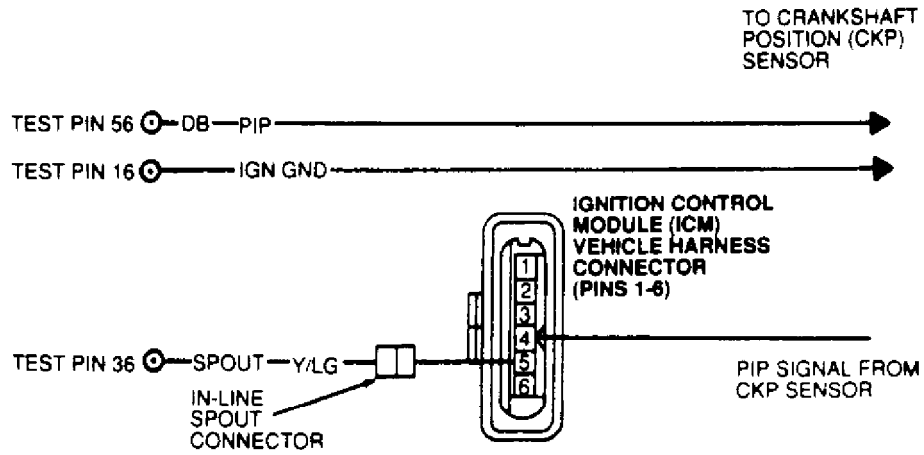

93G40804

Fig. 131: DIS Module Wiring Harness Connector Terminals (3.2L SHO)