

WIRING DIAGRAMS
Selected Block
 1993 Ford Taurus
 For <http://www.mitchell.narod.ru/>
 Copyright © 1997 Mitchell International
 Friday, March 02, 2001 02:32PM

I - EEC-IV SYS/COMP TEST

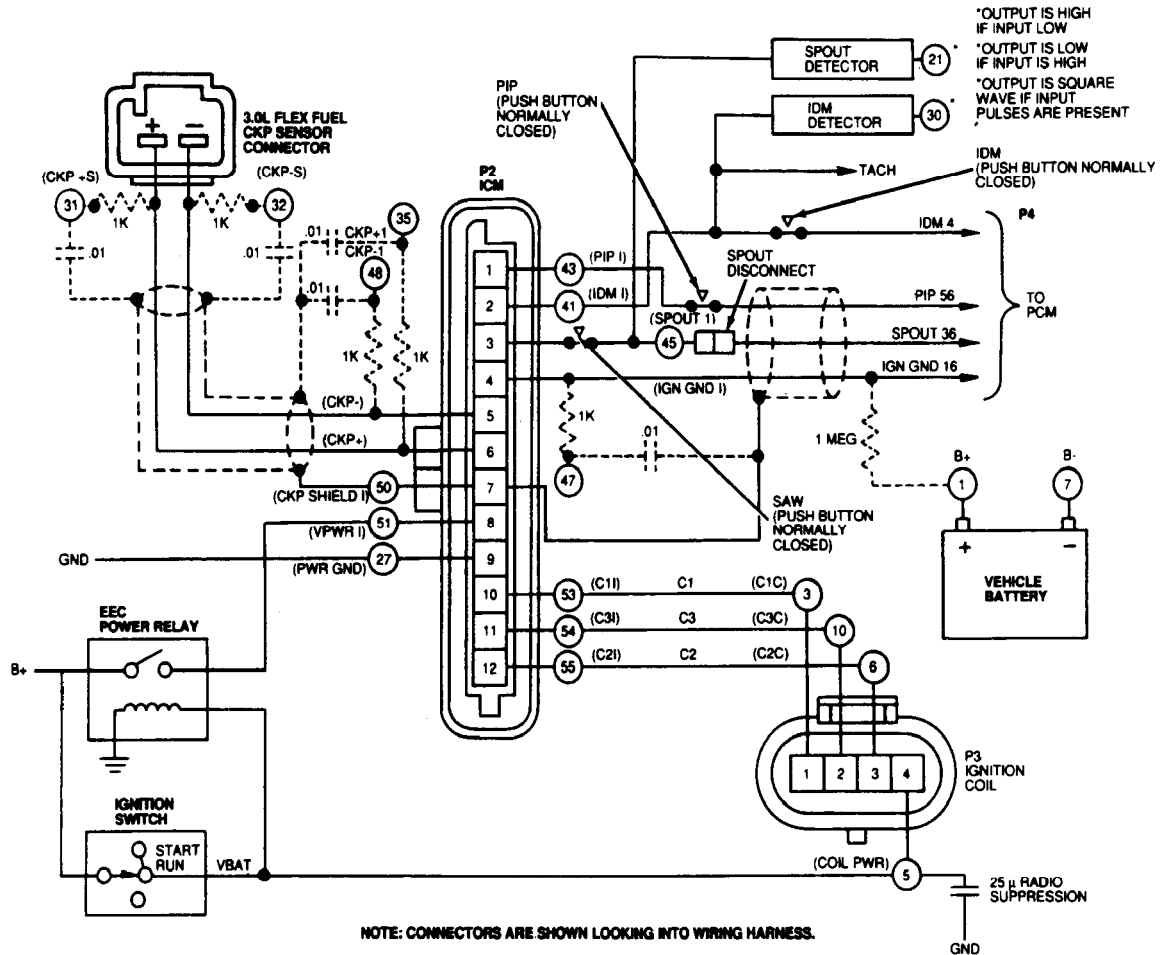

NOTE: CONNECTORS ARE SHOWN LOOKING INTO WIRING HARNESS.

RESISTORS AND CAPACITORS SHOWN IN DOTTED LINES ARE PART OF DIAGNOSTIC CABLE. NOTE VEHICLE WIRING.

CIRCLED NUMBERS ARE TEST JACKS ON BREAKOUT BOX.

COIL 1 DRIVES CYLINDERS 1 & 5 COIL 2 DRIVES CYLINDERS 3 & 4. COIL 3 DRIVES CYLINDERS 2 & 6.

PIN No.	3.0L Flexible Fuel
1	PIP I
2	IDM I
3	SPOUT I
4	IGN GND I
5	CKP-I
6	CKP+I
7	CKP Shield
8	VPWR I
9	PWR GND I
10	Coil 1 (CYL 1 and 5) I
11	Coil 3 (CYL 2 and 6) I
12	Coil 2 (CYL 3 and 4) I

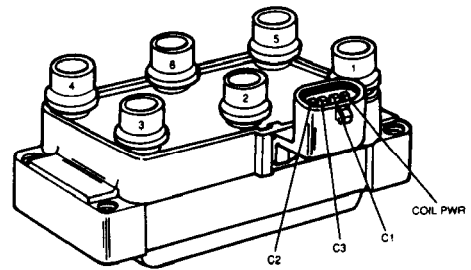

Fig. 132: EI Wiring Diagram (3.0L Flexible Fuel)

93I41481

WIRING DIAGRAMS

Selected Block (p. 2)

1993 Ford Taurus

For <http://www.mitchell.narod.ru/>

Copyright © 1997 Mitchell International

Friday, March 02, 2001 02:32PM

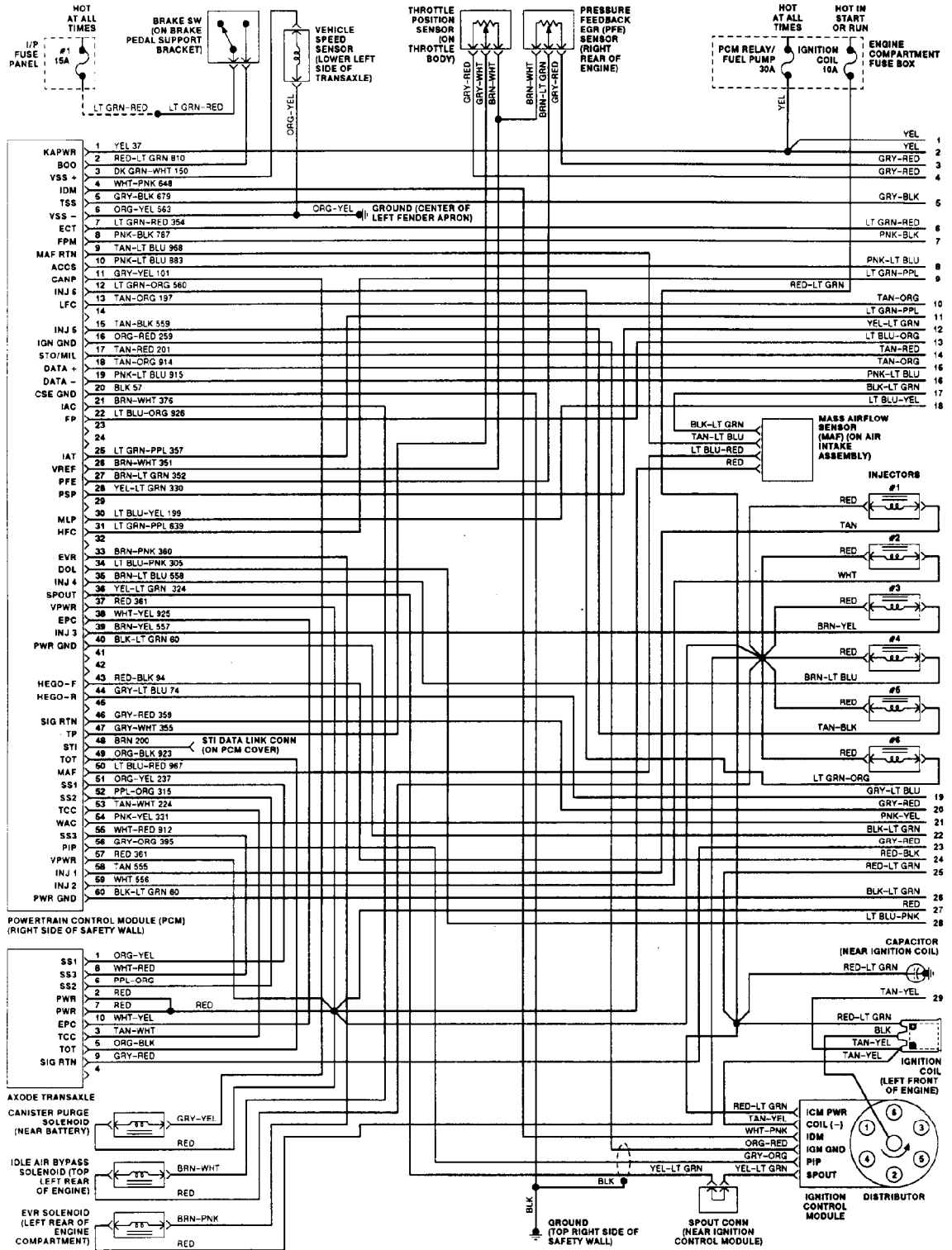

Fig. 133: EEC-IV Wiring Diagram (3.0L Except SHO 1 of 2)

WIRING DIAGRAMS

Selected Block (p. 3)

1993 Ford Taurus

For <http://www.mitchell.narod.ru/>

Copyright © 1997 Mitchell International

Friday, March 02, 2001 02:32PM

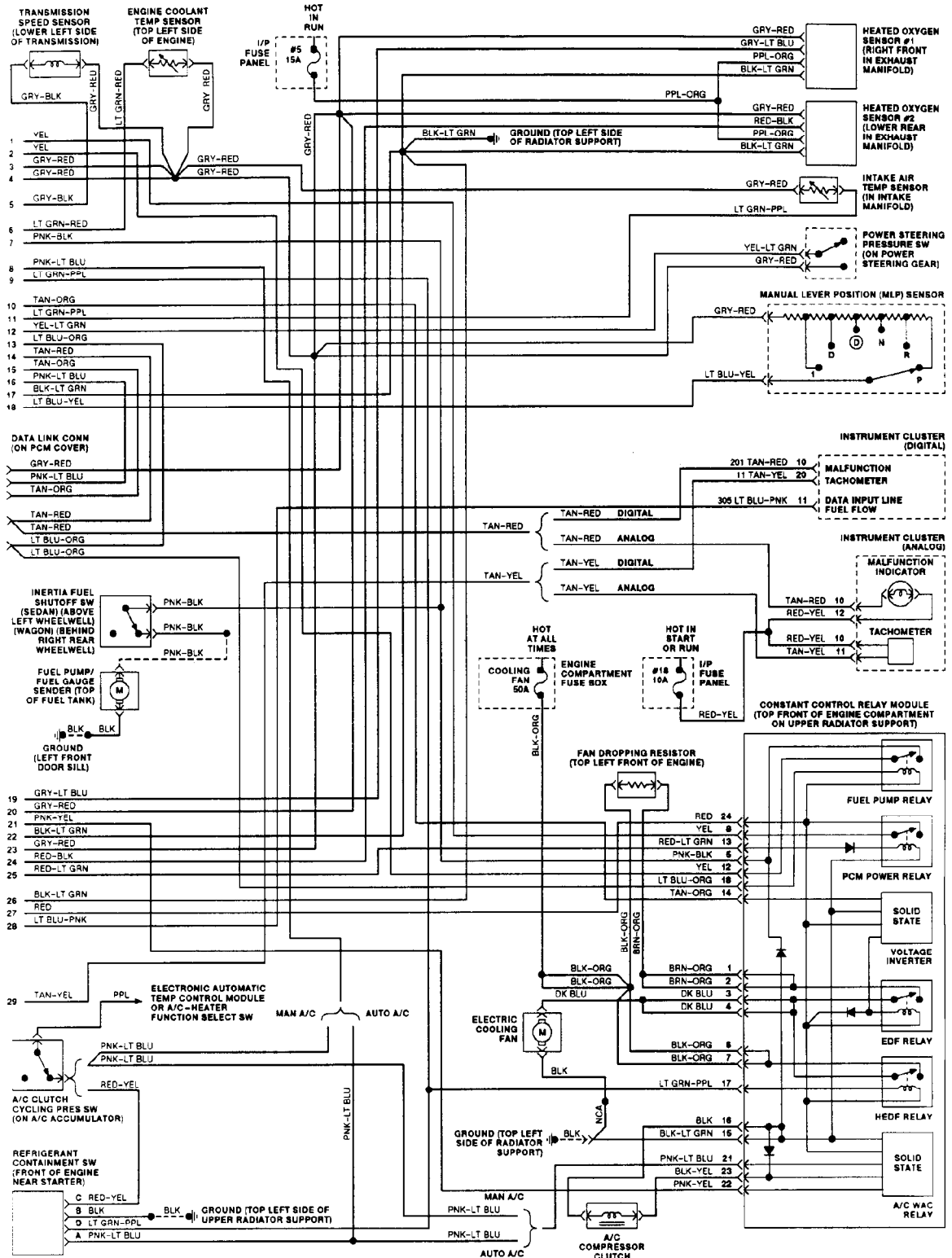

93A40659

Fig. 134: EEC-IV Wiring Diagram (3.0L Except SHO 2 of 2)

WIRING DIAGRAMS

Selected Block (p. 4)

1993 Ford Taurus

For <http://www.mitchell.narod.ru/>

Copyright © 1997 Mitchell International

Friday, March 02, 2001 02:32PM

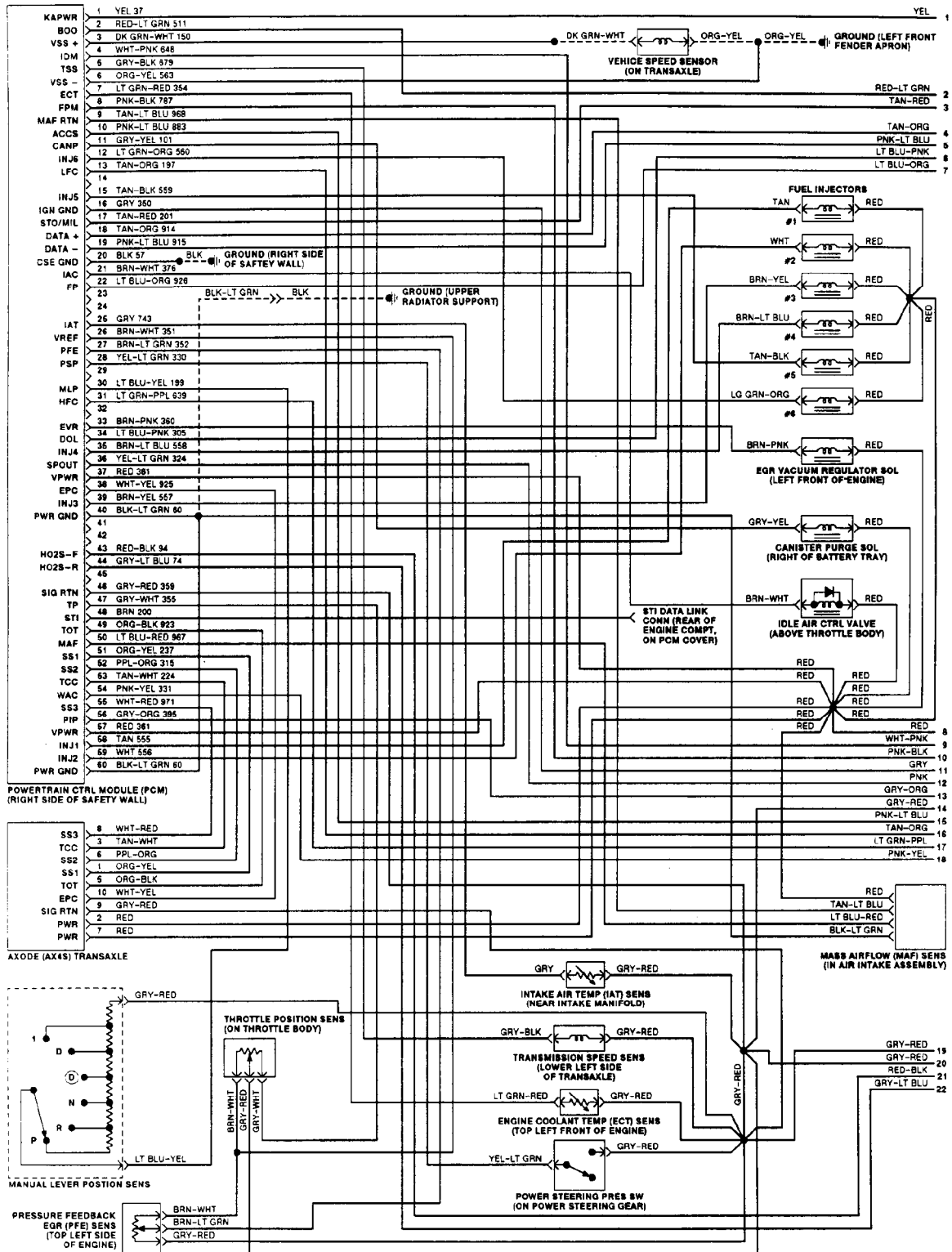

93D40680

Fig. 135: EEC-IV Wiring Diagram (3.8L - 1 of 2)

WIRING DIAGRAMS

Selected Block (p. 5)

1993 Ford Taurus

For <http://www.mitchell.narod.ru/>

Copyright © 1997 Mitchell International

Friday, March 02, 2001 02:32PM

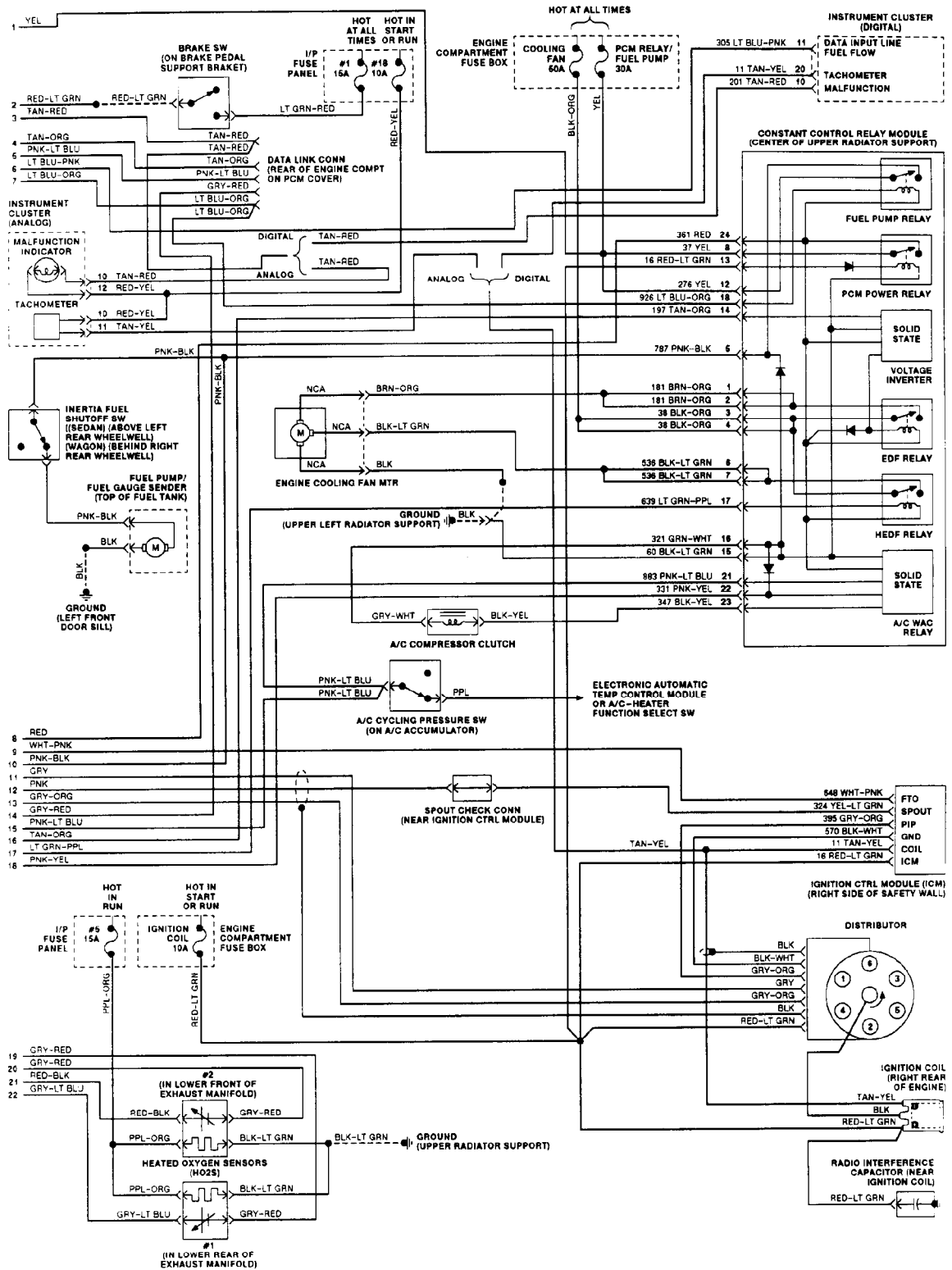

93E40661

Fig. 136: EEC-IV Wiring Diagram (3.8L - 2 of 2)

WIRING DIAGRAMS

Selected Block (p. 6)

1993 Ford Taurus

For <http://www.mitchell.narod.ru/>

Copyright © 1997 Mitchell International

Friday, March 02, 2001 02:32PM

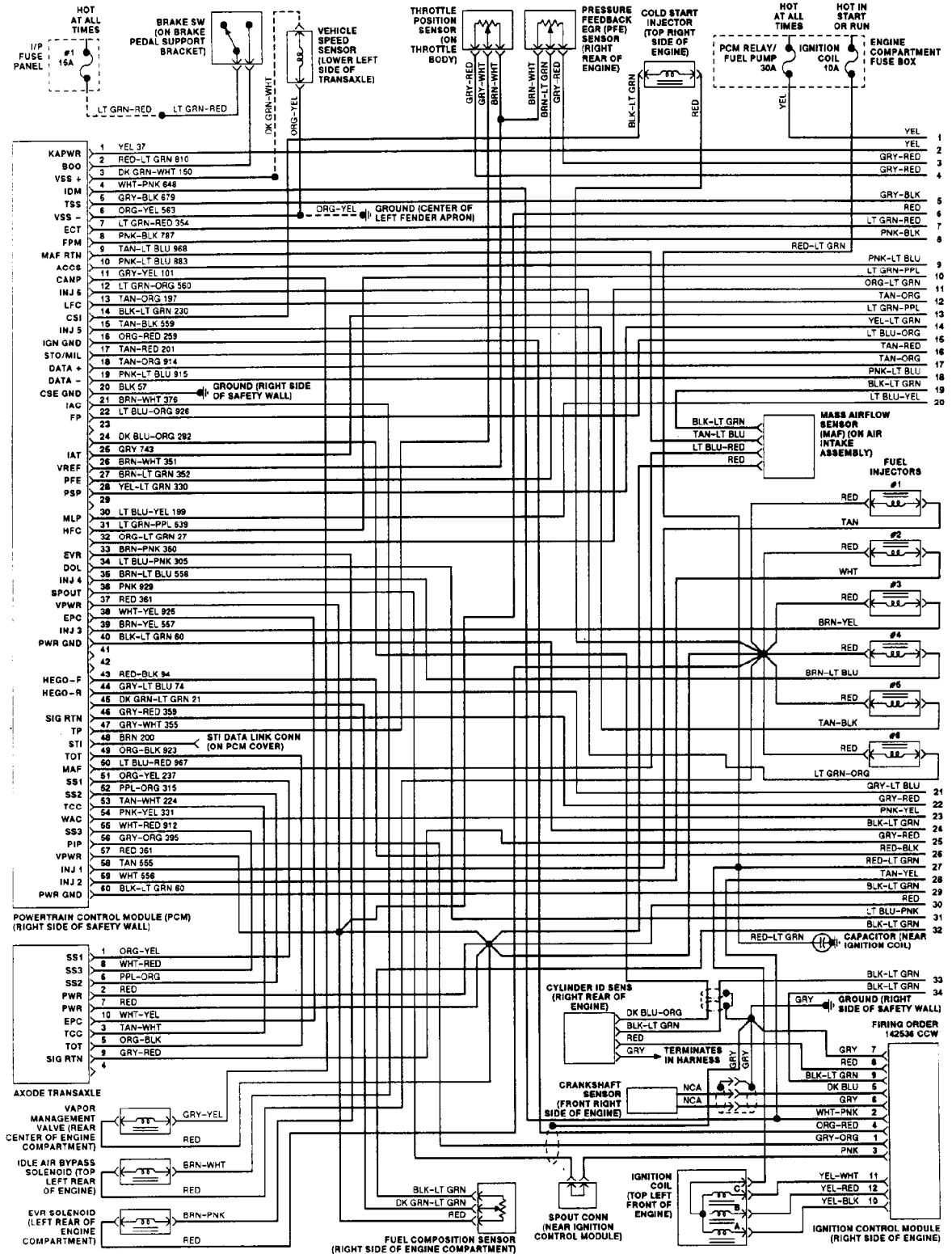

93F40662

Fig. 137: EEC-IV Wiring Diagram (3.0L Flex Fuel - 1 of 2)

WIRING DIAGRAMS

Selected Block (p. 7)

1993 Ford Taurus

For <http://www.mitchell.narod.ru/>

Copyright © 1997 Mitchell International

Friday, March 02, 2001 02:32PM

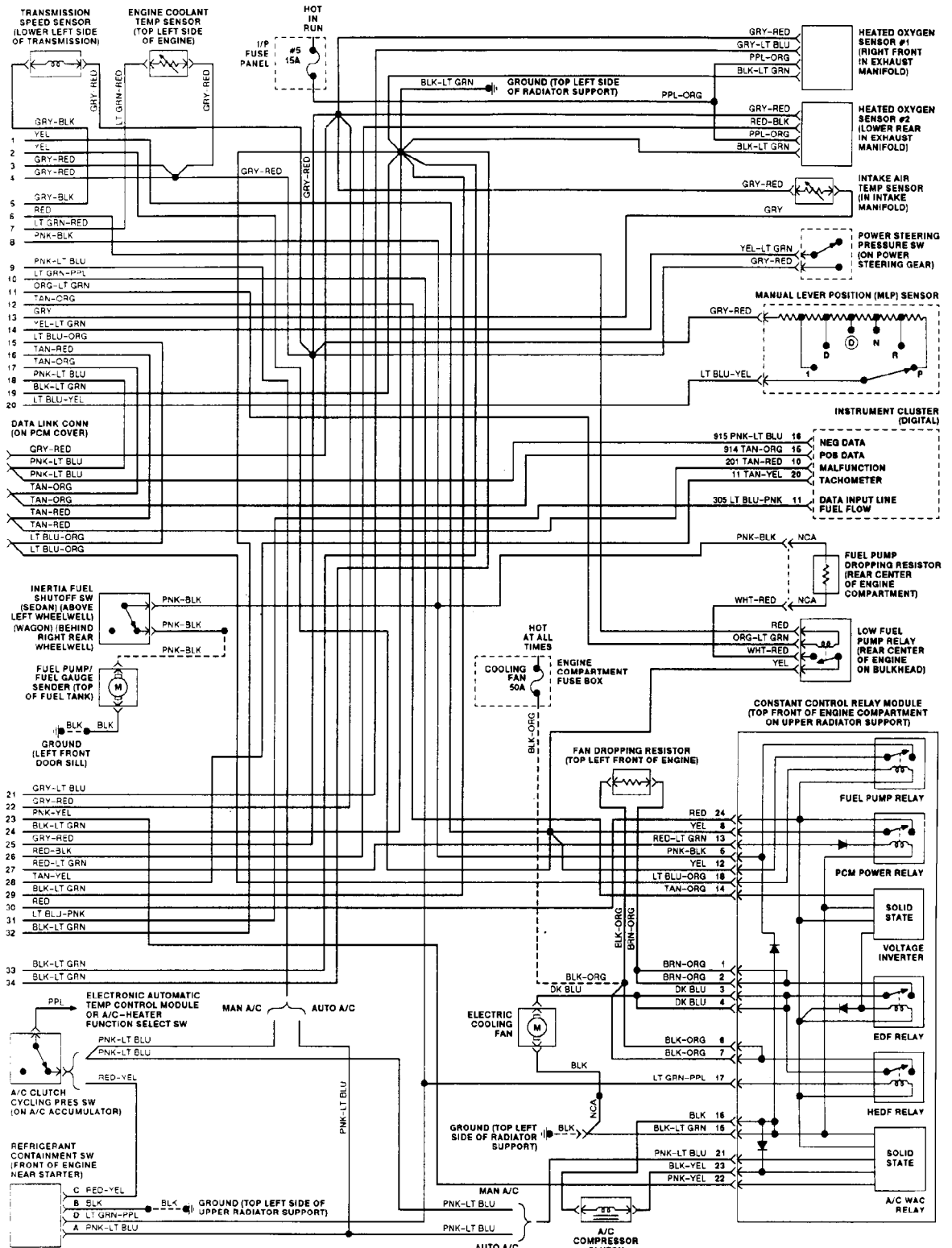

93G40663

Fig. 138: EEC-IV Wiring Diagram (3.0L Flex Fuel - 2 of 2)

WIRING DIAGRAMS

Selected Block (p. 8)

1993 Ford Taurus

For <http://www.mitchell.narod.ru/>

Copyright © 1997 Mitchell International

Friday, March 02, 2001 02:32PM

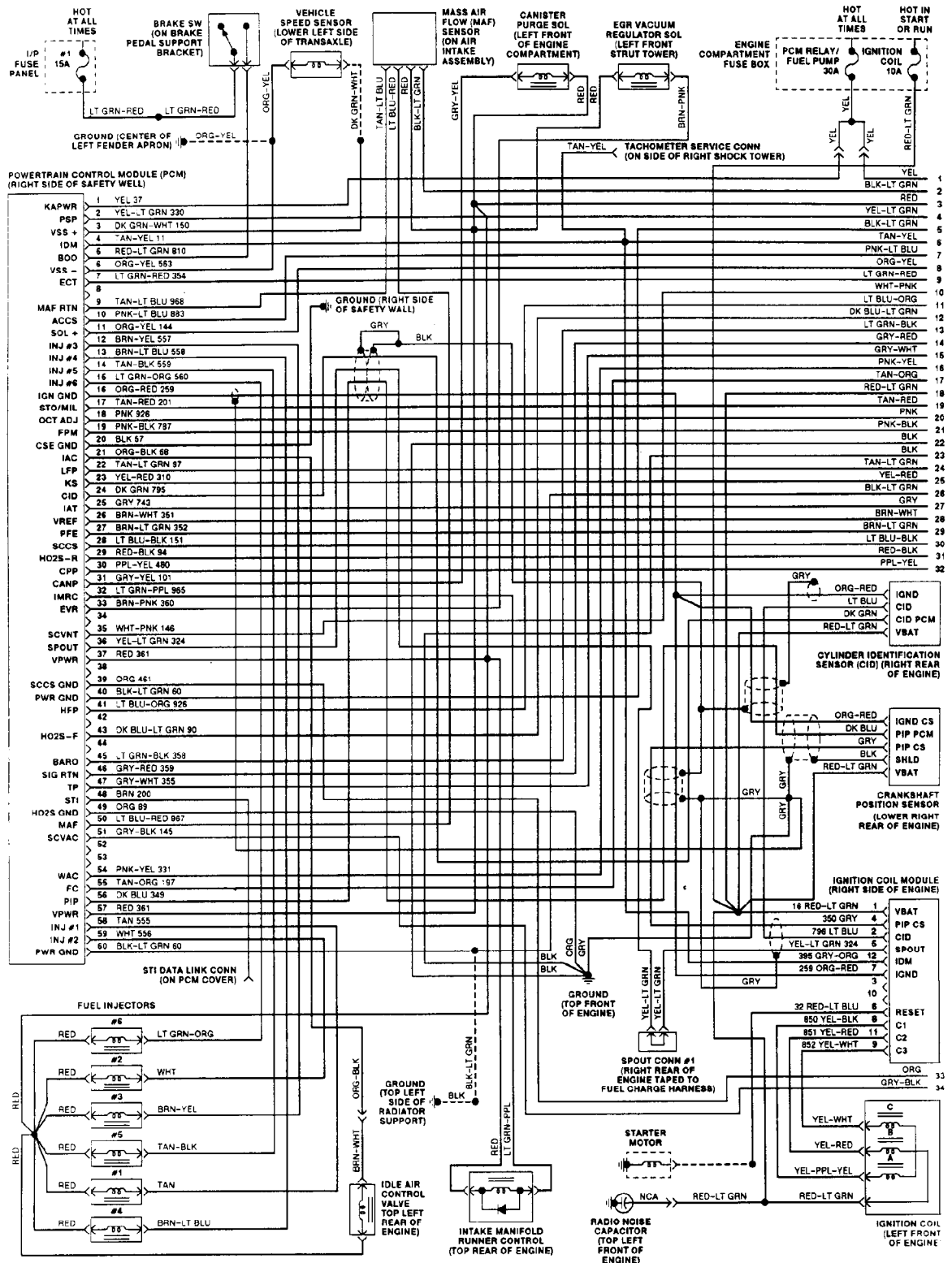

93H40664

Fig. 139: EEC-IV Wiring Diagram (3.0L SHO - 1 of 2)

WIRING DIAGRAMS

Selected Block (p. 9)

1993 Ford Taurus

For <http://www.mitchell.narod.ru/>

Copyright © 1997 Mitchell International

Friday, March 02, 2001 02:32PM

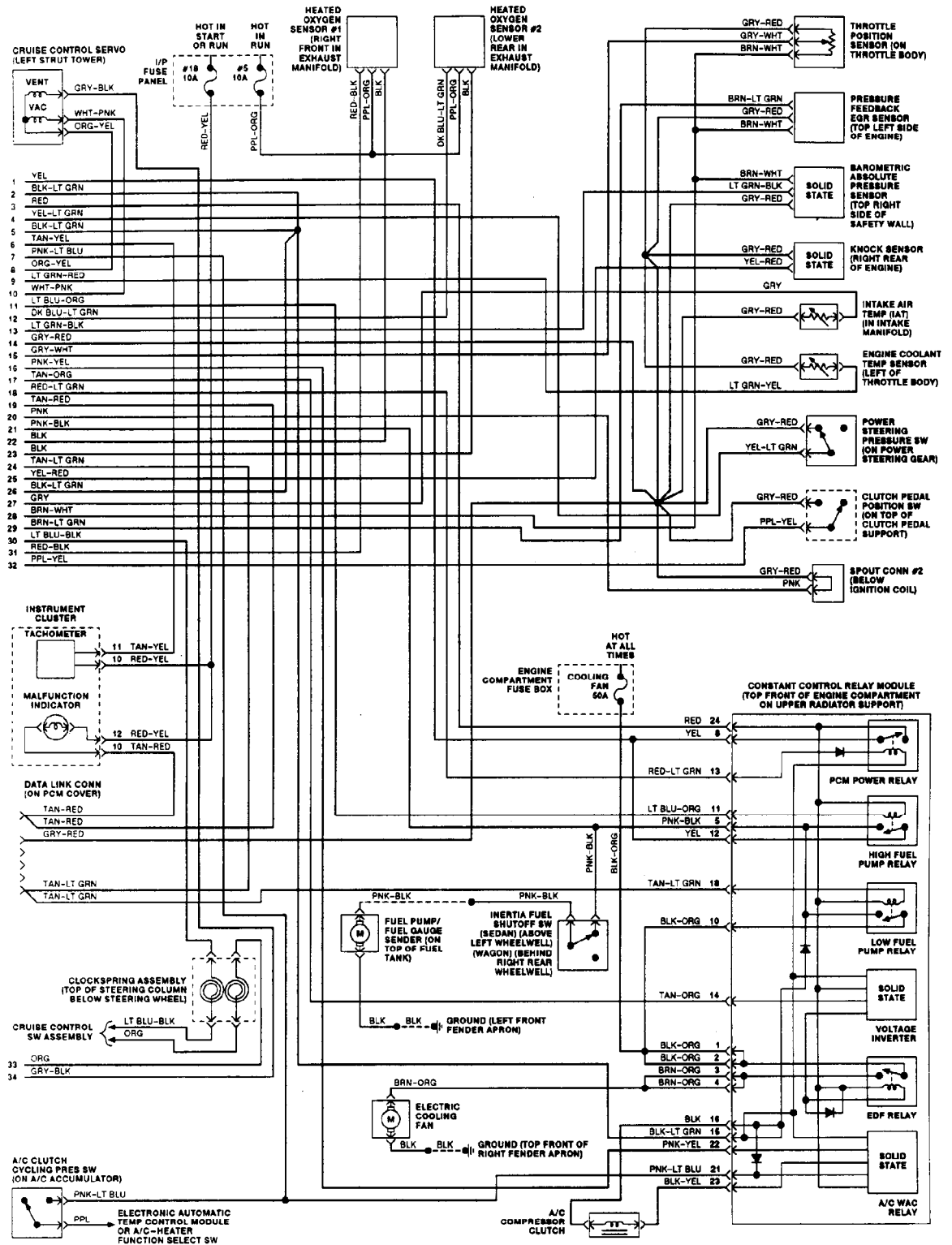

93I40665

Fig. 140: EEC-IV Wiring Diagram (3.0L SHO - 2 of 2)

WIRING DIAGRAMS

Selected Block (p. 10)

1993 Ford Taurus

For <http://www.mitchell.narod.ru/>
 Copyright © 1997 Mitchell International
 Friday, March 02, 2001 02:32PM

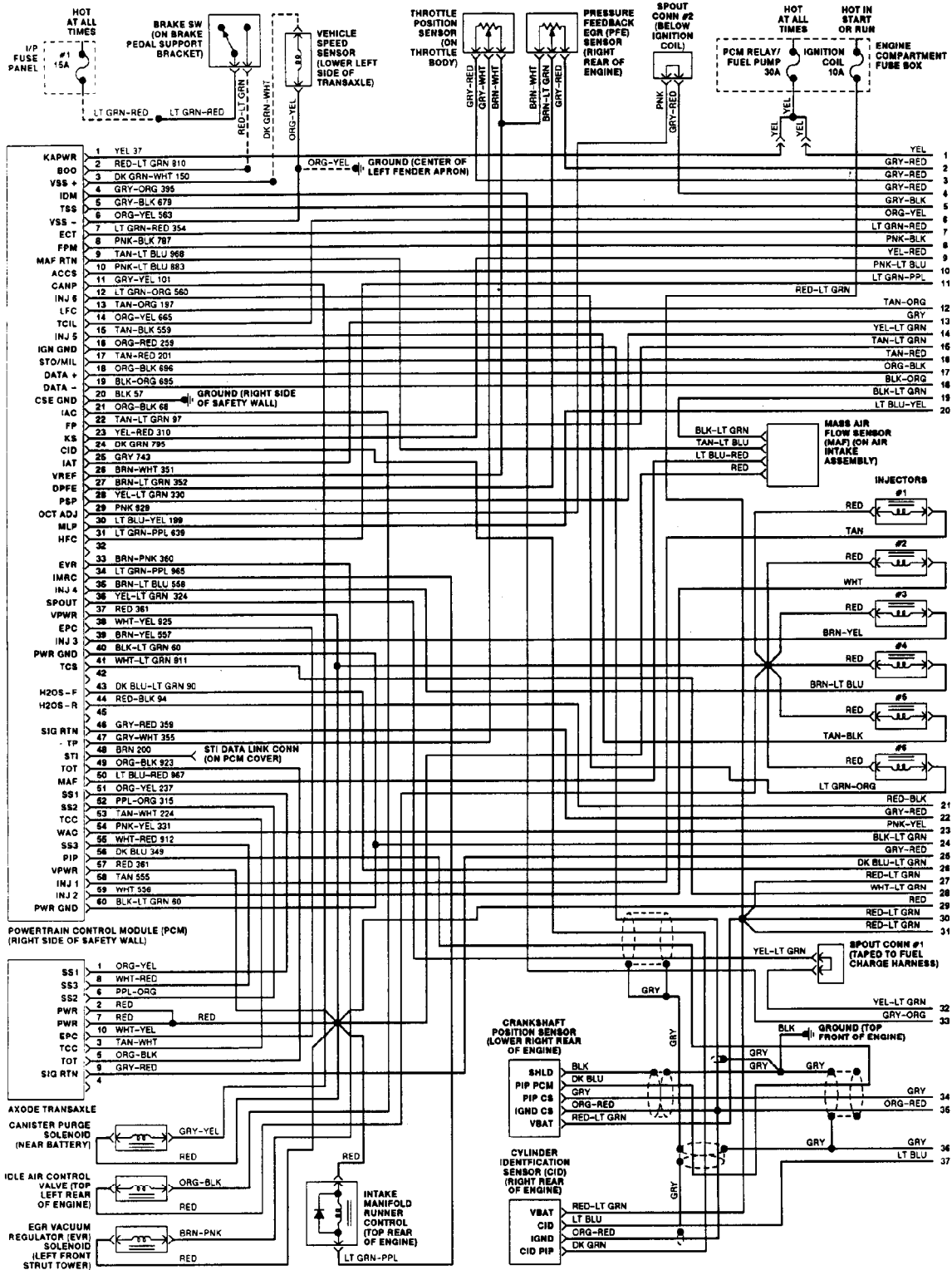

93J40666

Fig. 141: EEC-IV Wiring Diagram (3.2L SHO - 1 of 2)

WIRING DIAGRAMS

Selected Block (p. 11)

1993 Ford Taurus

For <http://www.mitchell.narod.ru/>

Copyright © 1997 Mitchell International

Friday, March 02, 2001 02:32PM

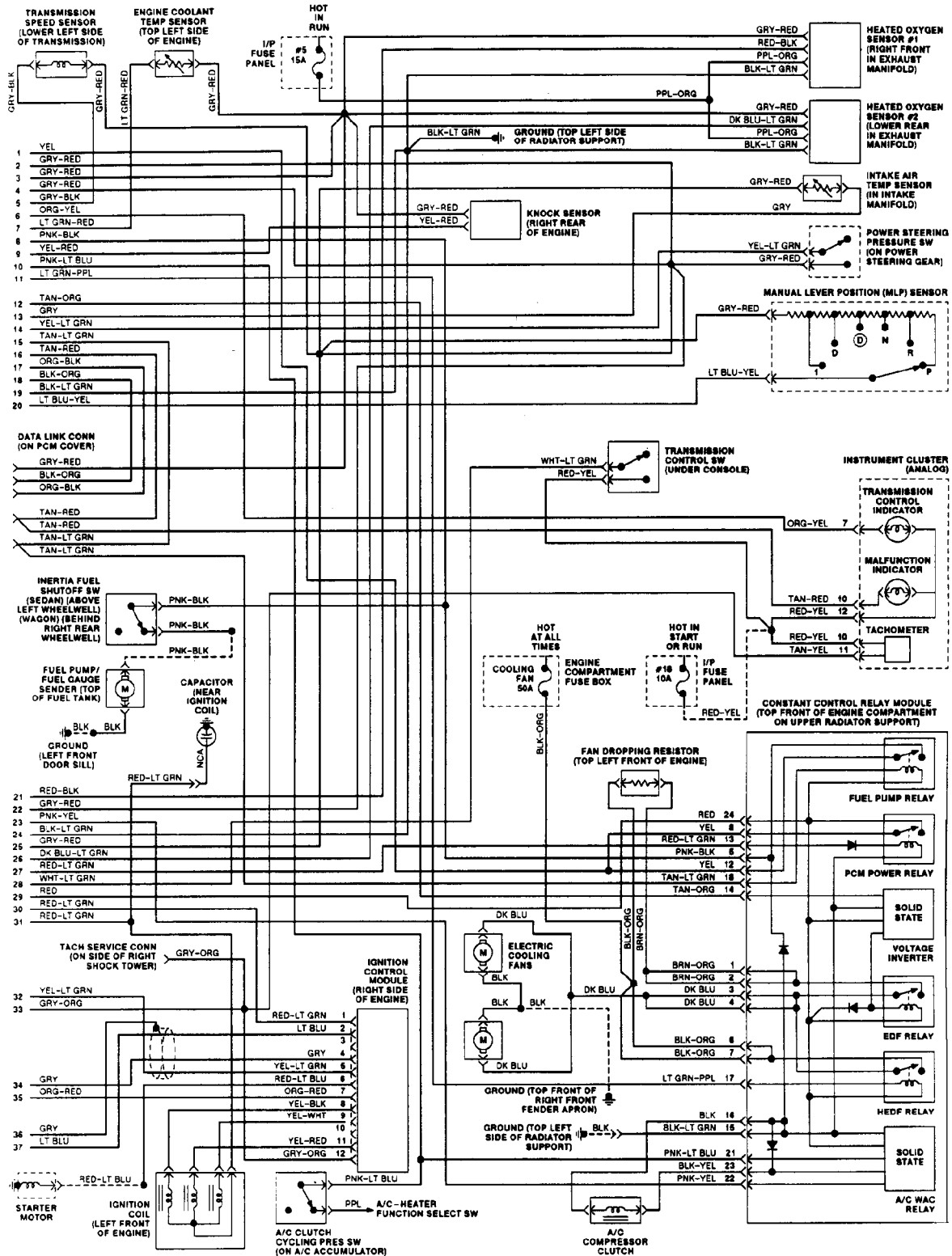

93A40667

Fig. 142: EEC-IV Wiring Diagram (3.2L SHO - 2 of 2)

POWER STEERING SYSTEM

WIRING DIAGRAMS

Selected Block (p. 12)

1993 Ford Taurus

For <http://www.mitchell.narod.ru/>
 Copyright © 1997 Mitchell International
 Friday, March 02, 2001 02:32PM

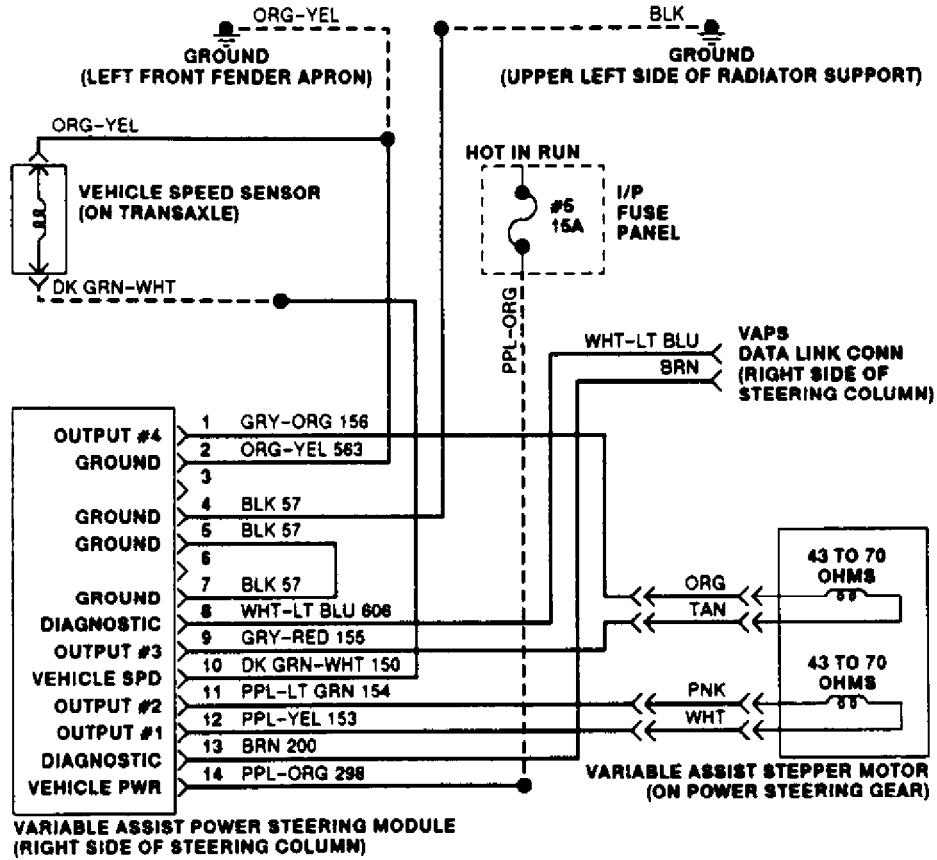

93J42209

Fig. 143: Power Steering Module Wiring Diagram (SHO)

END OF ARTICLE