

SYSTEM WIRING DIAGRAMS

Selected Block

1994 Ford Taurus

For <http://www.mitchell.narod.ru/>

Copyright © 1997 Mitchell International

Friday, March 02, 2001 09:00PM

1994 System Wiring Diagrams

Ford - Taurus

ANTI-LOCK BRAKES

3.0L

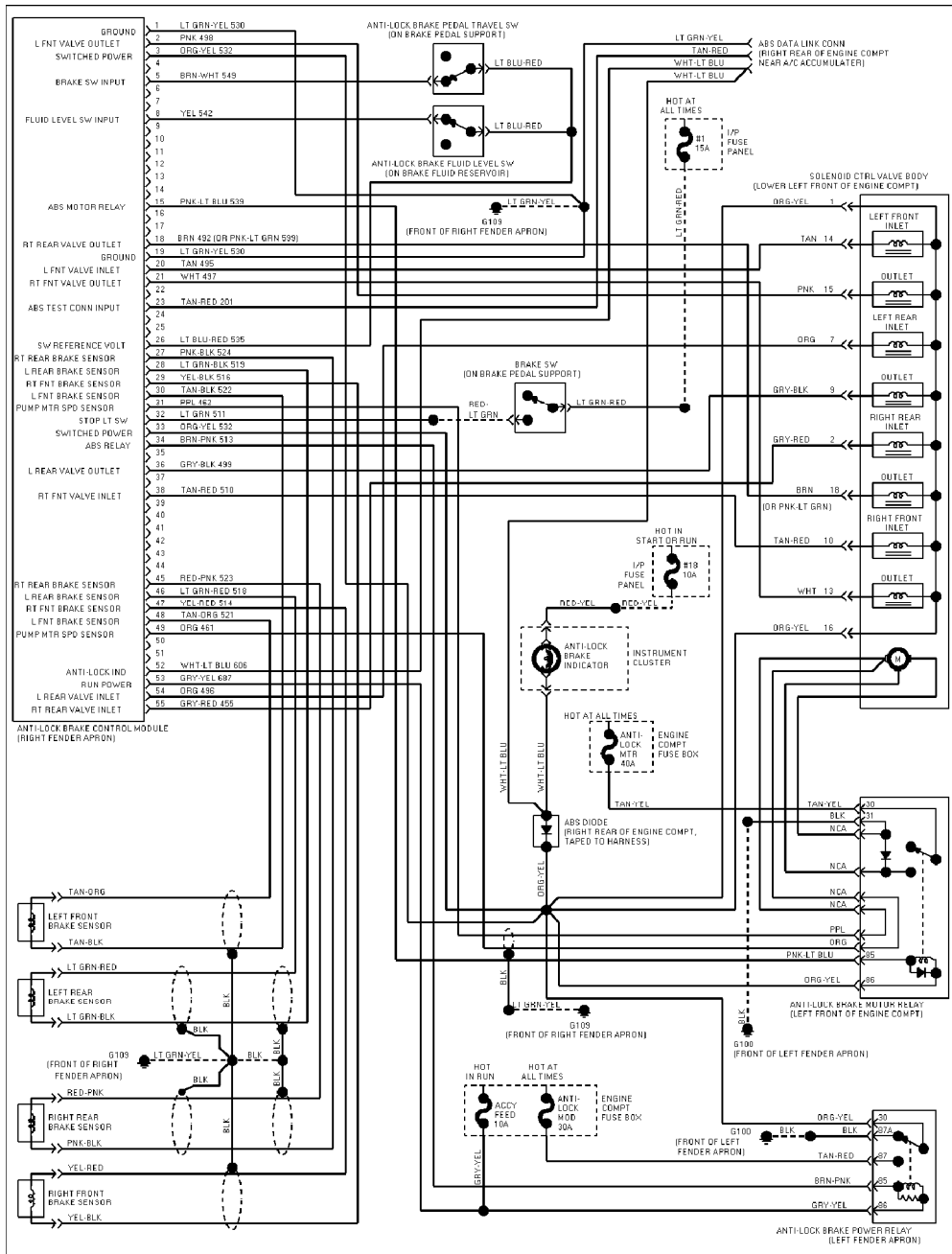

3.0L Flex Fuel, Anti-lock Brake Circuits

SYSTEM WIRING DIAGRAMS

Selected Block (p. 2)

1994 Ford Taurus

For <http://www.mitchell.narod.ru/>

Copyright © 1997 Mitchell International

Friday, March 02, 2001 09:00PM

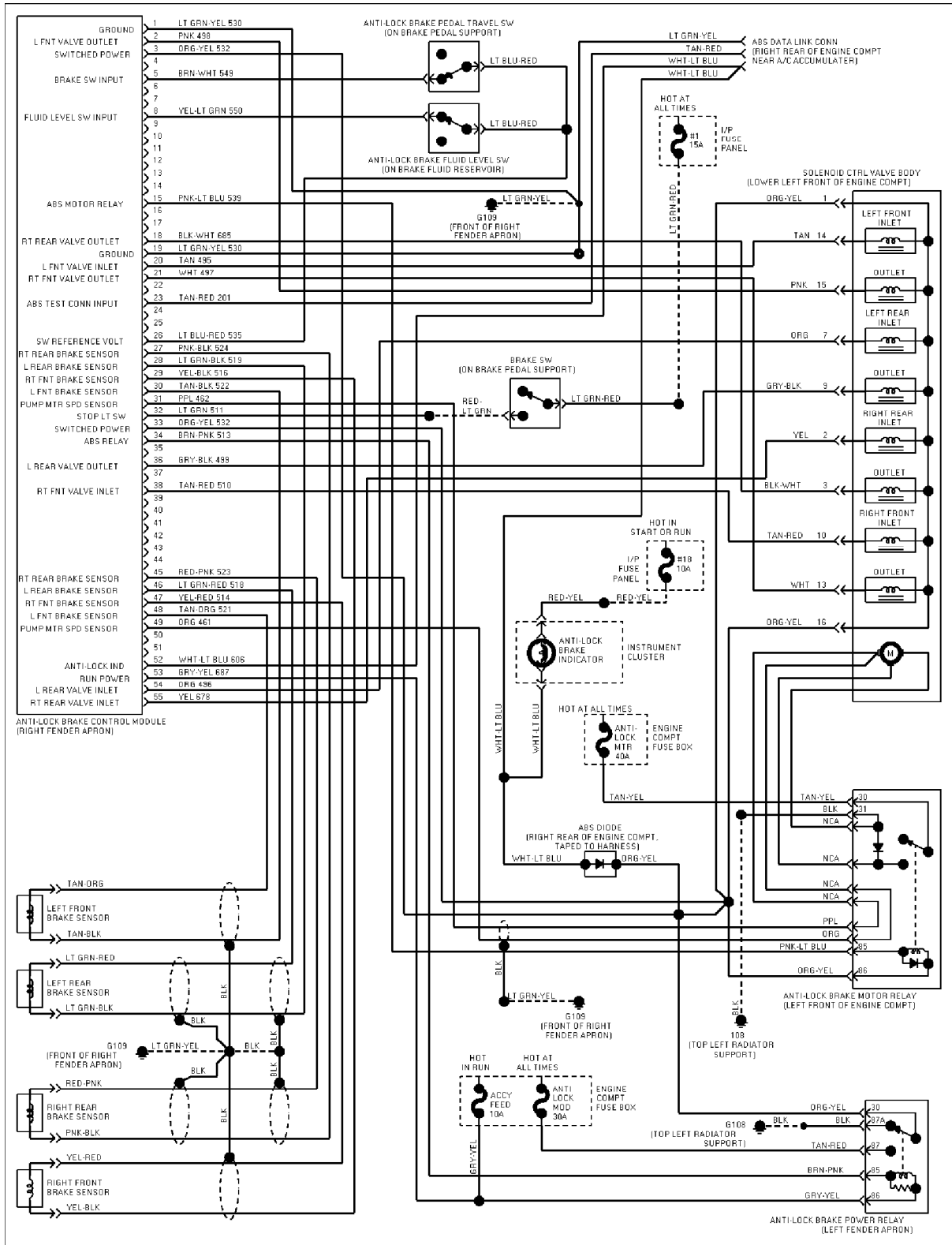

3.0L SHO, Anti-lock Brake Circuits

SYSTEM WIRING DIAGRAMS

Selected Block (p. 3)

1994 Ford Taurus

For <http://www.mitchell.narod.ru/>

Copyright © 1997 Mitchell International

Friday, March 02, 2001 09:00PM

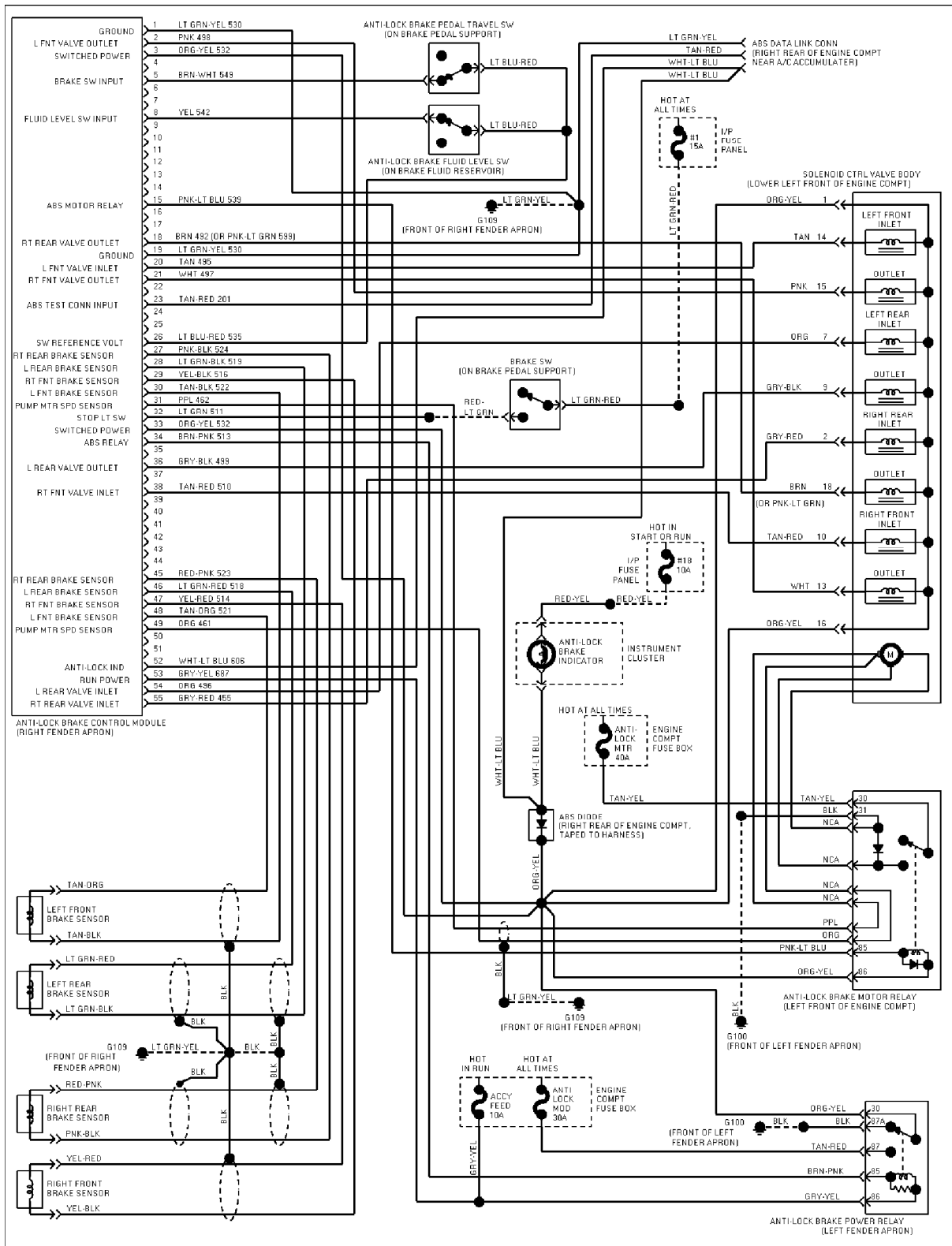

3.0L, Anti-lock Brake Circuits

3.2L

SYSTEM WIRING DIAGRAMS

Selected Block (p. 4)

1994 Ford Taurus

For <http://www.mitchell.narod.ru/>

Copyright © 1997 Mitchell International

Friday, March 02, 2001 09:00PM

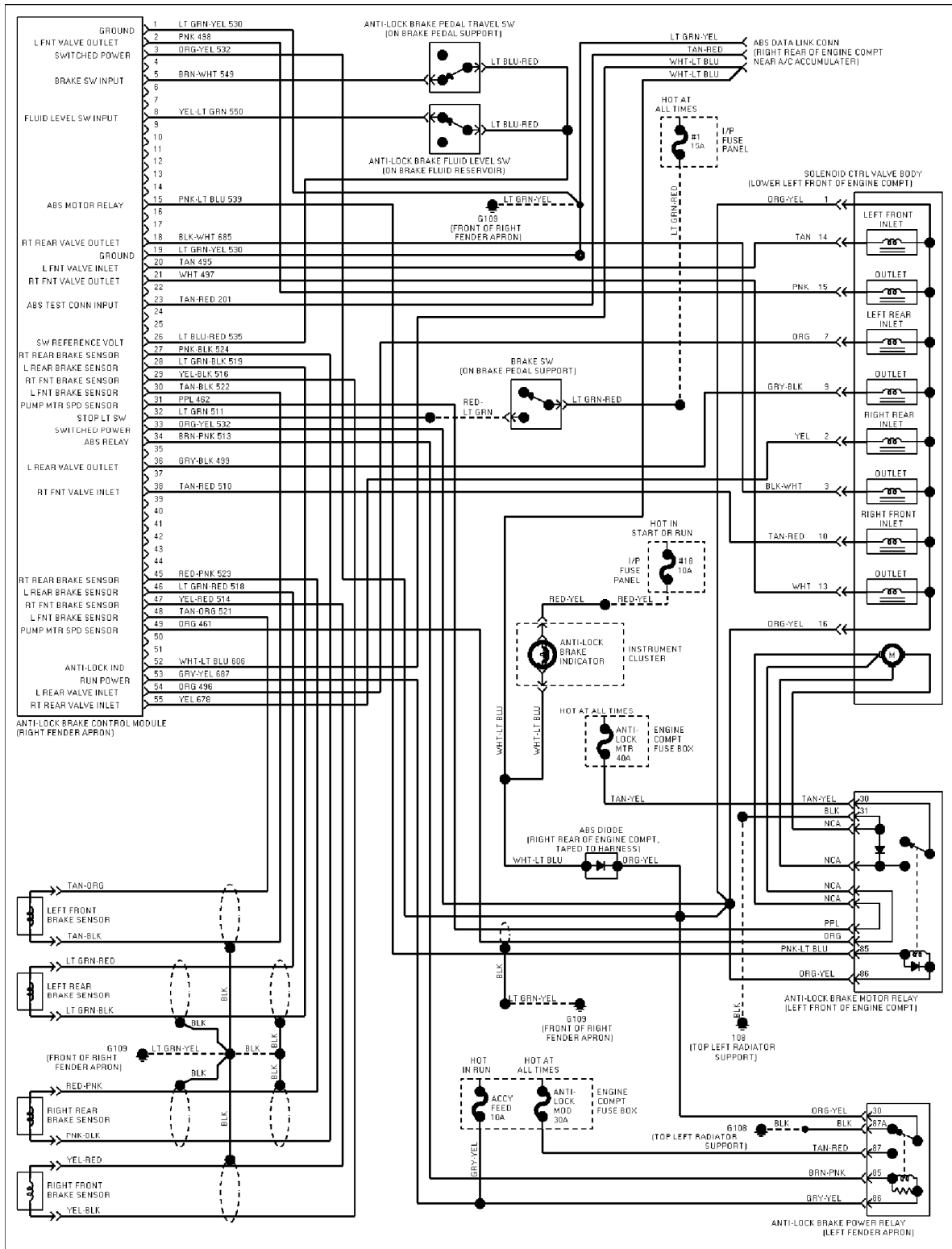

3.2L SHO, Anti-lock Brake Circuits

3.8L

SYSTEM WIRING DIAGRAMS

Selected Block (p. 5)

1994 Ford Taurus

For <http://www.mitchell.narod.ru/>

Copyright © 1997 Mitchell International

Friday, March 02, 2001 09:00PM

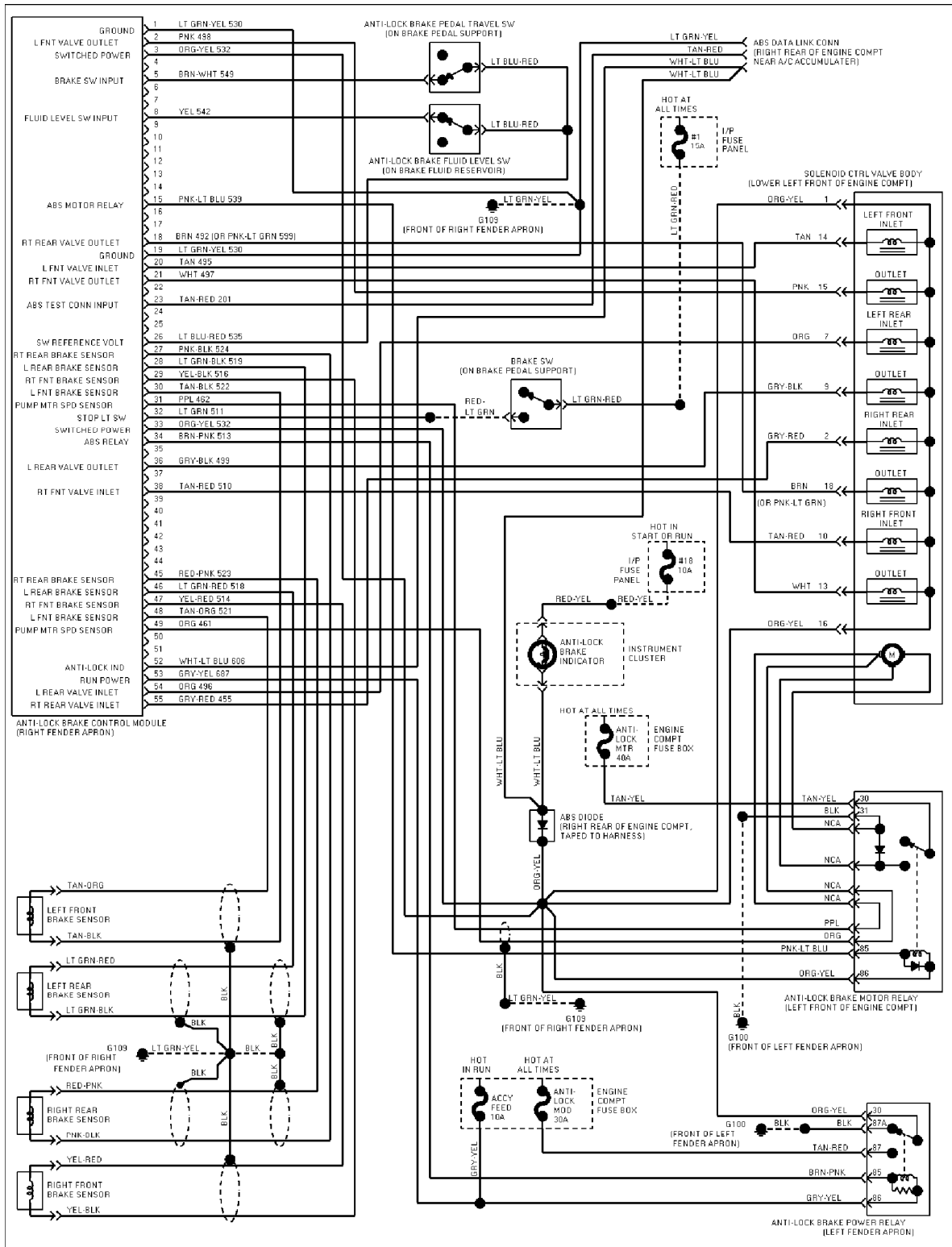

3.8L, Anti-lock Brake Circuits