

SYSTEM WIRING DIAGRAMS

Selected Block

1994 Ford Taurus

For <http://www.mitchell.narod.ru/>

Copyright © 1997 Mitchell International

Friday, March 02, 2001 09:01PM

ELECTRONIC POWER STEERING

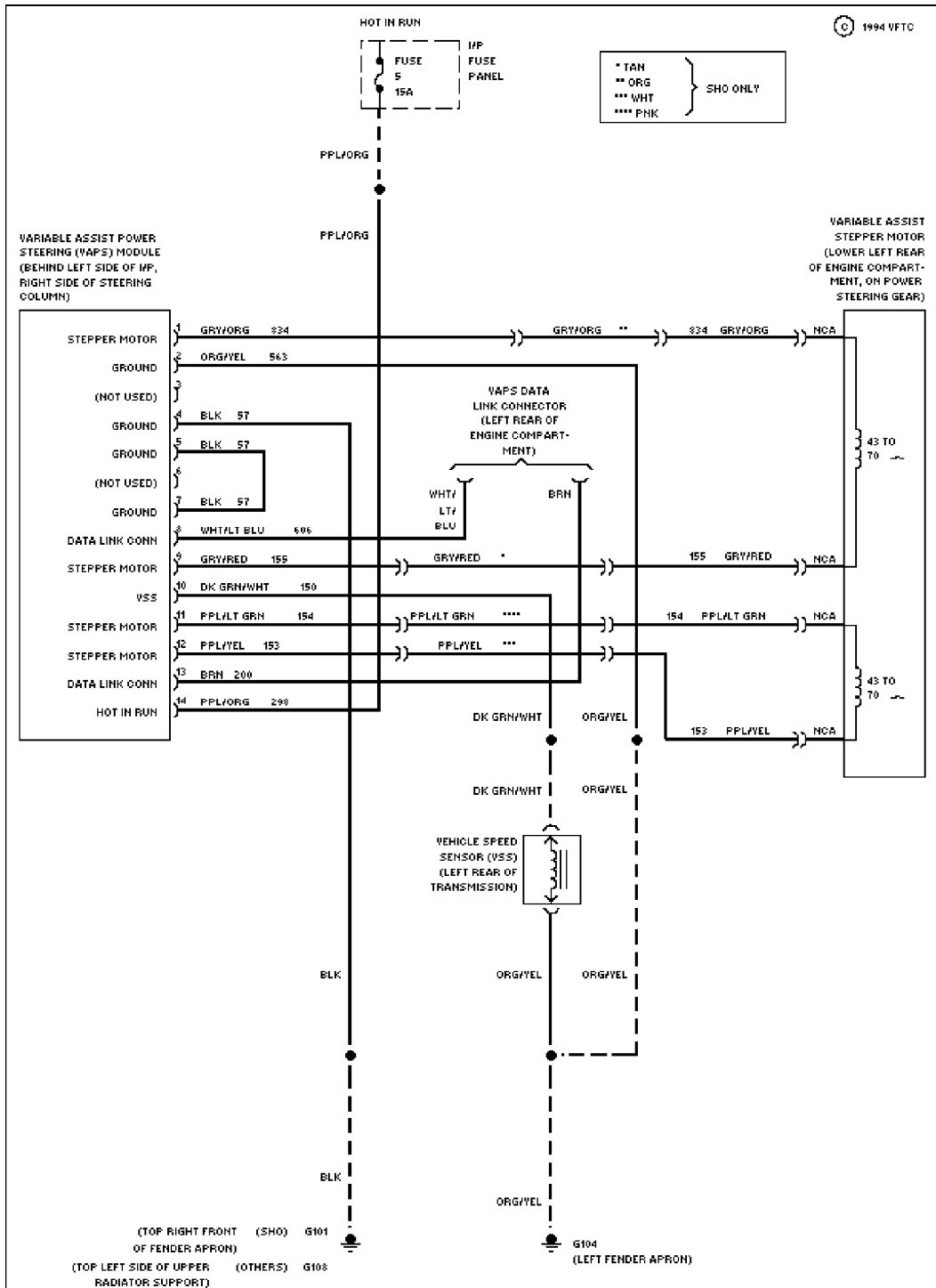

57383 Electronic Power Steering Circuit

SYSTEM WIRING DIAGRAMS

Selected Block (p. 2)

1994 Ford Taurus

For <http://www.mitchell.narod.ru/>

Copyright © 1997 Mitchell International

Friday, March 02, 2001 09:01PM

ENGINE PERFORMANCE

3.0L

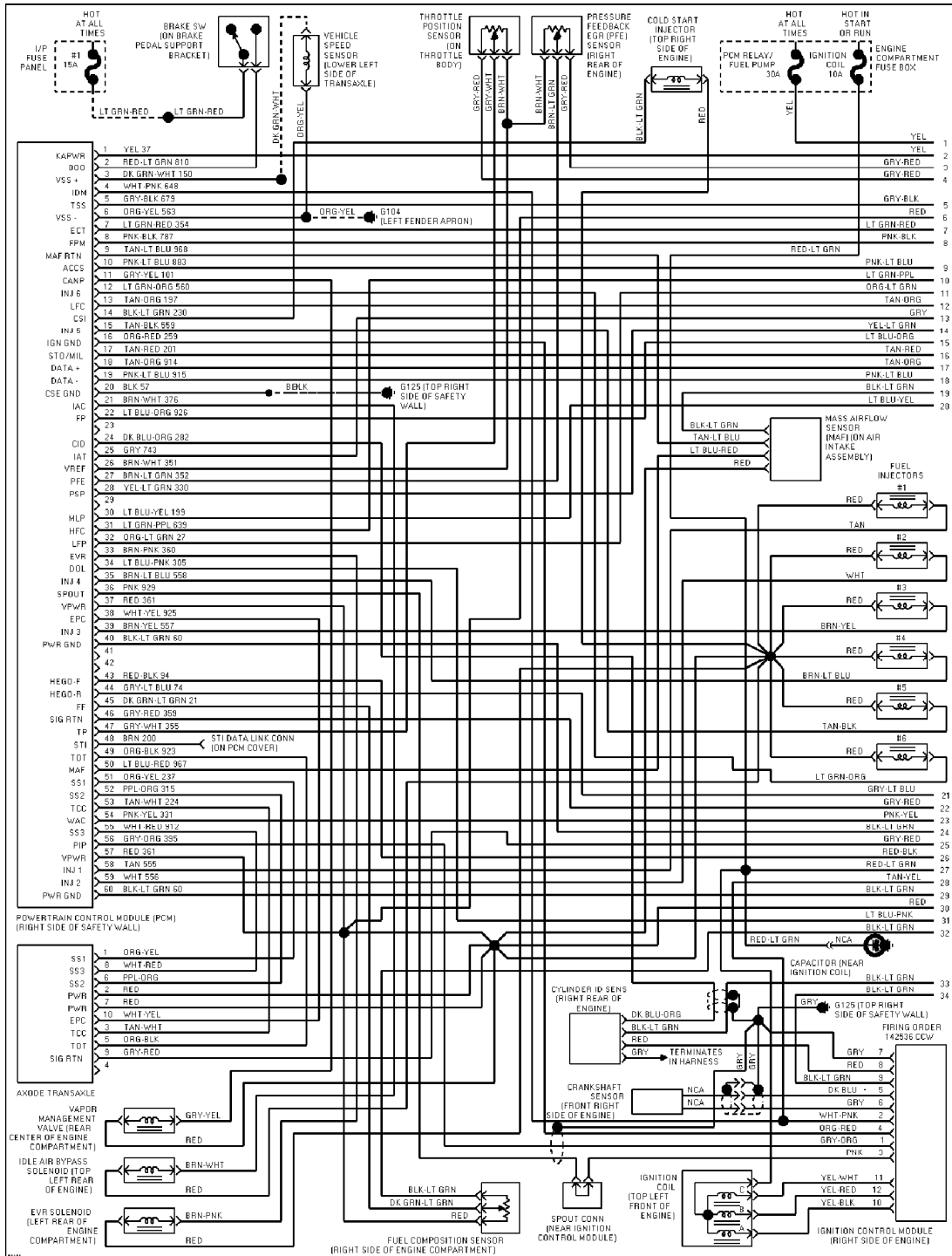

3.0L Flex Fuel, Engine Performance Circuits (1 of 2)

SYSTEM WIRING DIAGRAMS

Selected Block (p. 3)

1994 Ford Taurus

For <http://www.mitchell.narod.ru/>

Copyright © 1997 Mitchell International

Friday, March 02, 2001 09:01PM

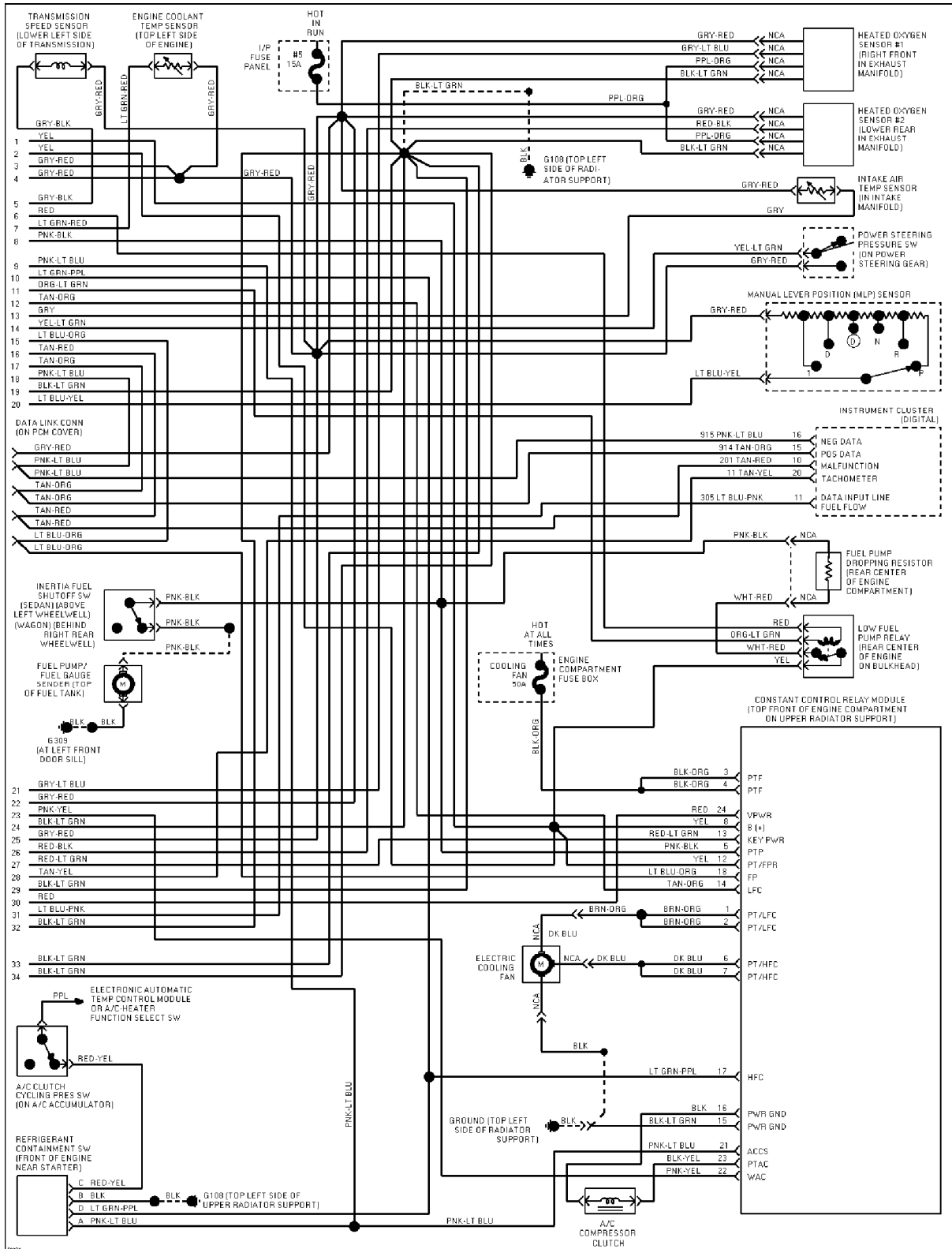

3.0L Flex Fuel, Engine Performance Circuits (2 of 2)

SYSTEM WIRING DIAGRAMS

Selected Block (p. 4)

1994 Ford Taurus

For <http://www.mitchell.narod.ru/>

Copyright © 1997 Mitchell International

Friday, March 02, 2001 09:01PM

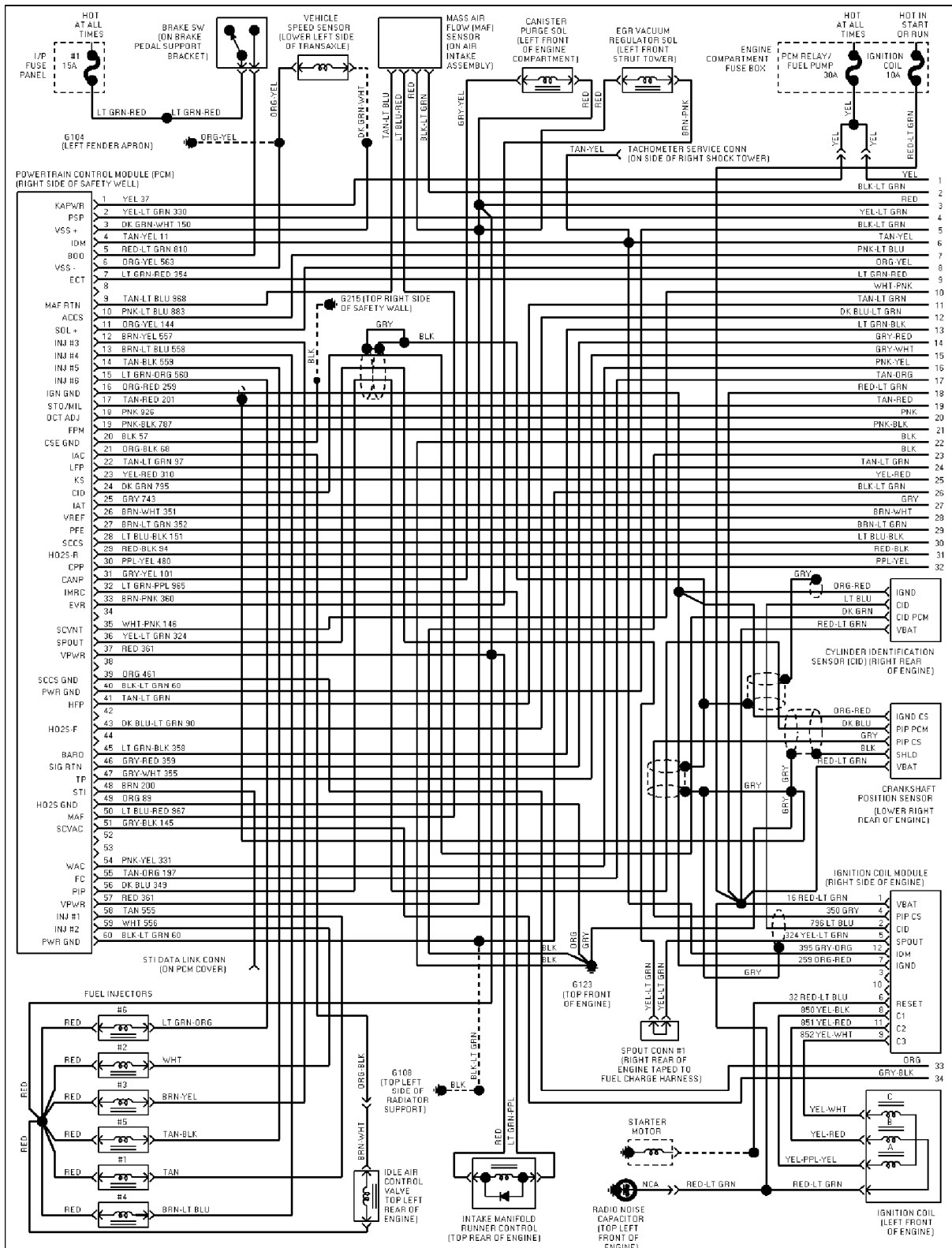

SYSTEM WIRING DIAGRAMS

Selected Block (p. 5)

1994 Ford Taurus

For <http://www.mitchell.narod.ru/>

Copyright © 1997 Mitchell International

Friday, March 02, 2001 09:01PM

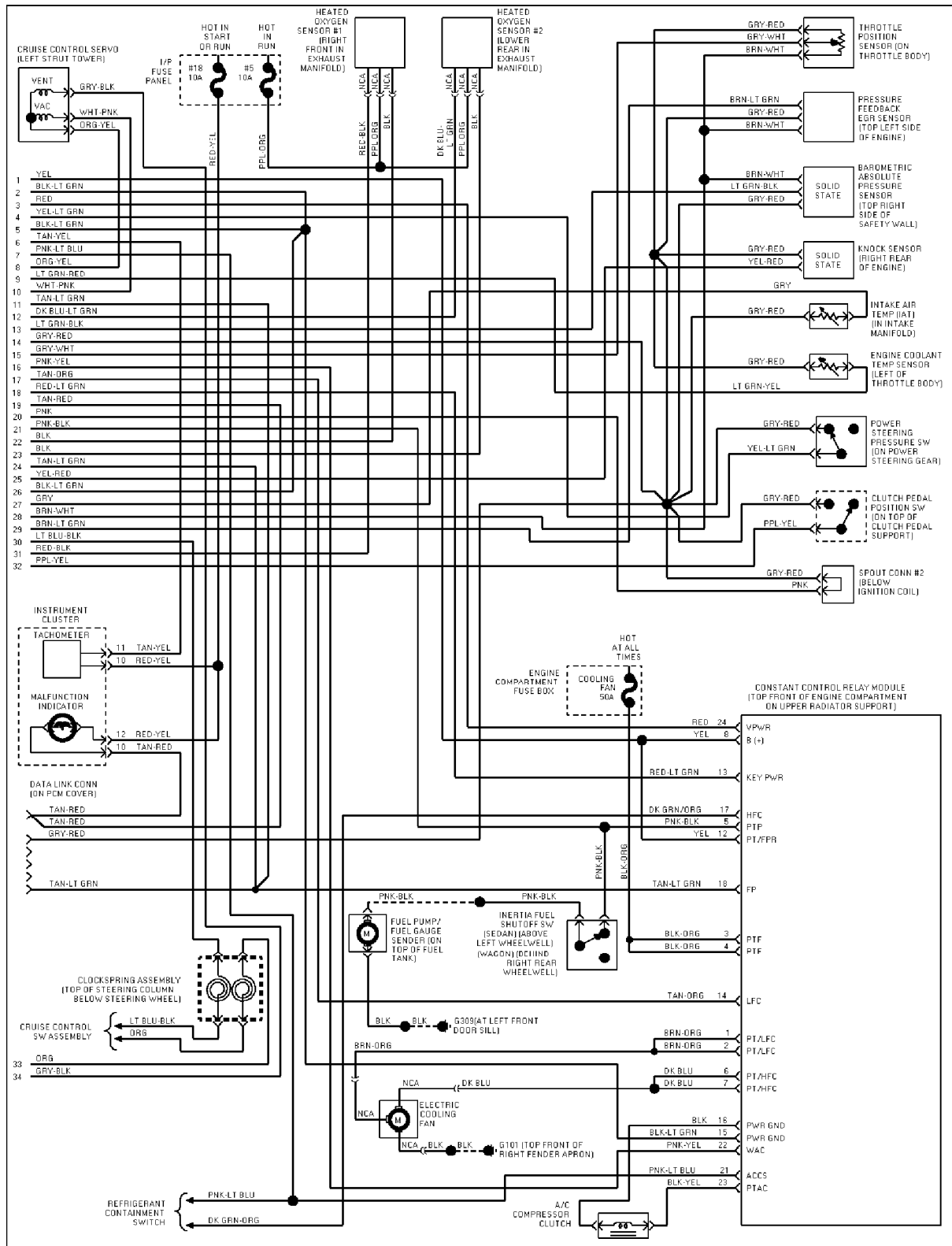

3.0L SHO, Engine Performance Circuits (2 of 2)

SYSTEM WIRING DIAGRAMS

Selected Block (p. 6)

1994 Ford Taurus

For <http://www.mitchell.narod.ru/>

Copyright © 1997 Mitchell International

Friday, March 02, 2001 09:01PM

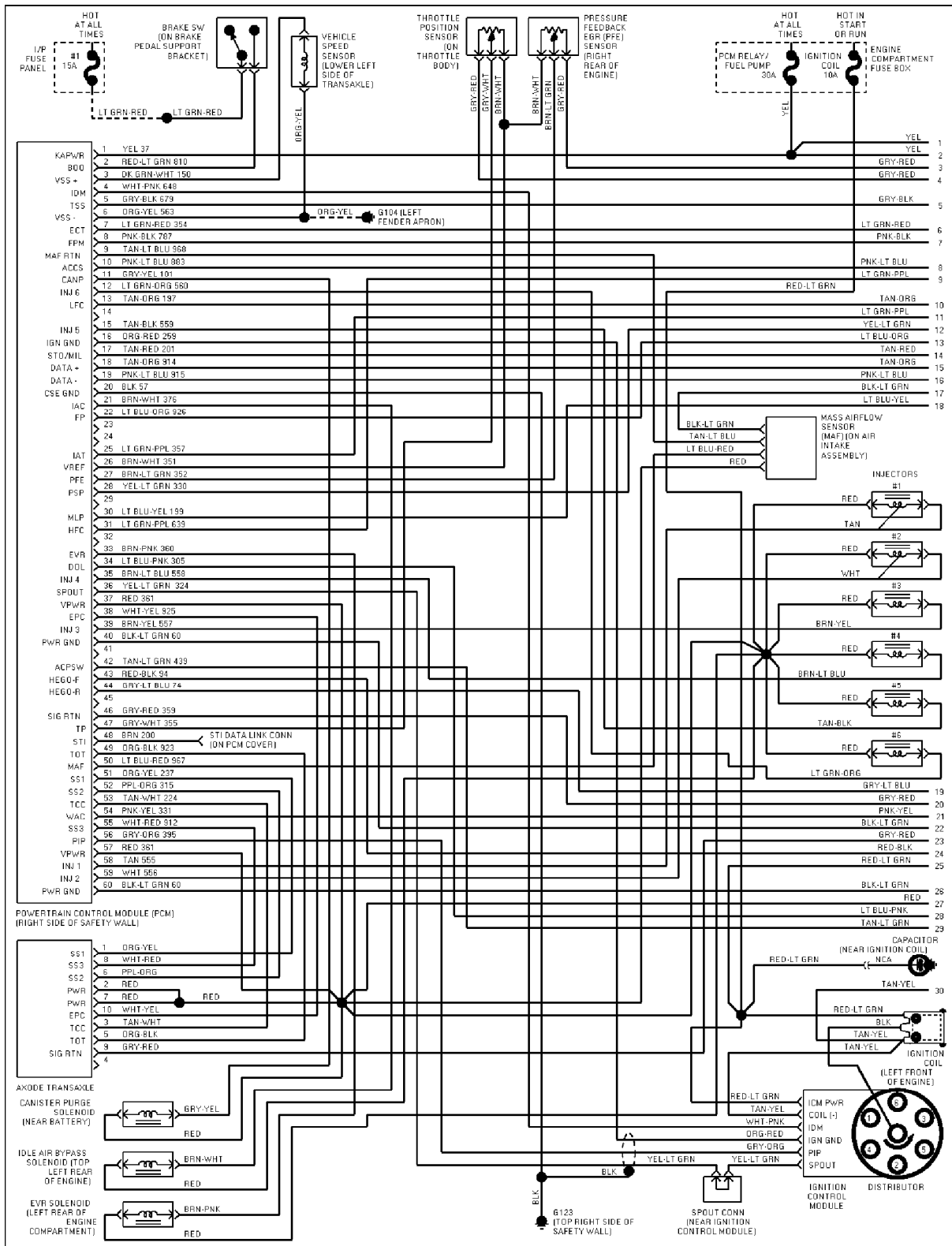

SYSTEM WIRING DIAGRAMS

Selected Block (p. 7)

1994 Ford Taurus

For <http://www.mitchell.narod.ru/>

Copyright © 1997 Mitchell International

Friday, March 02, 2001 09:01PM

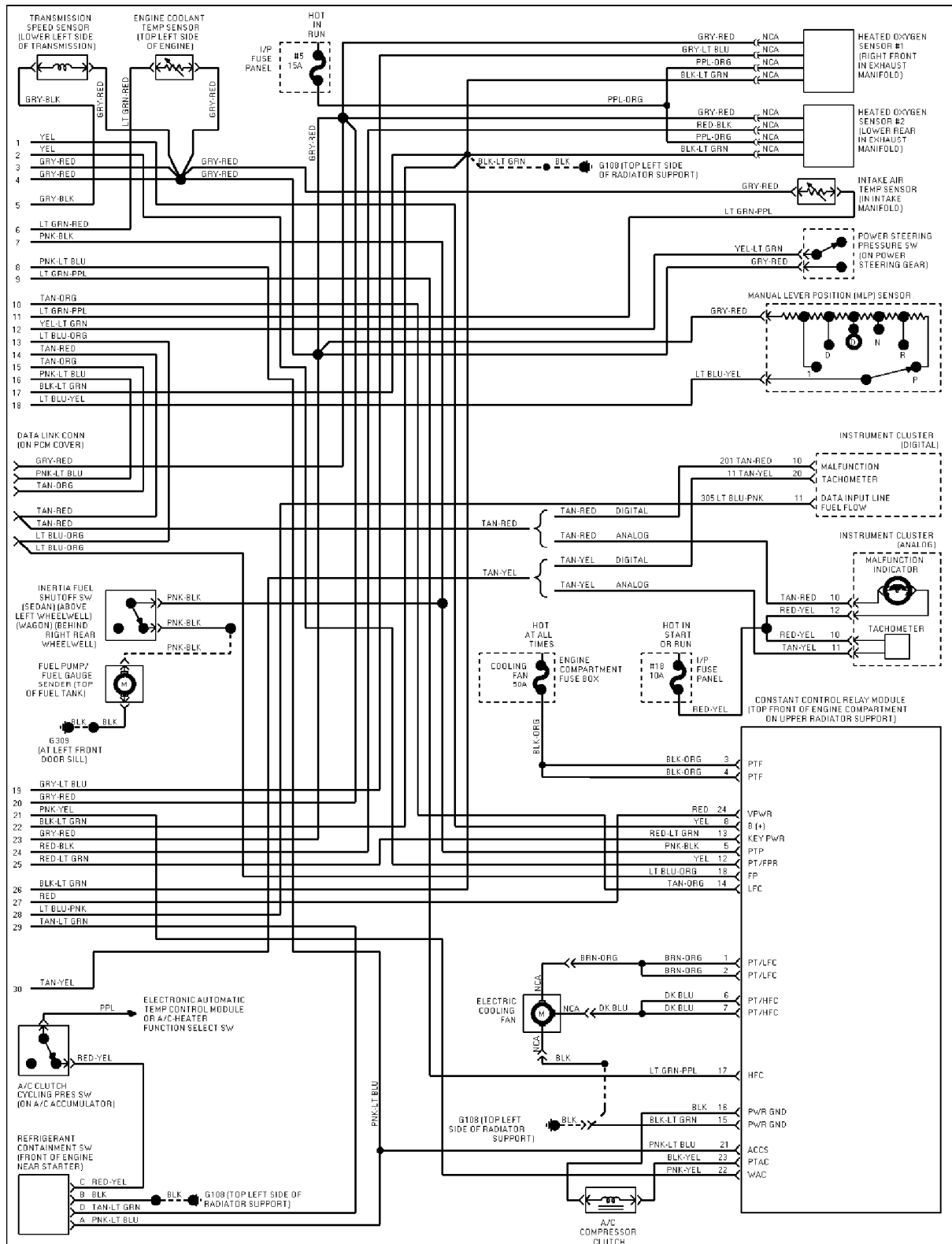

3.0L, Engine Performance Circuits (2 of 2)

3.2L

SYSTEM WIRING DIAGRAMS

Selected Block (p. 8)

1994 Ford Taurus

For <http://www.mitchell.narod.ru/>

Copyright © 1997 Mitchell International

Friday, March 02, 2001 09:01PM

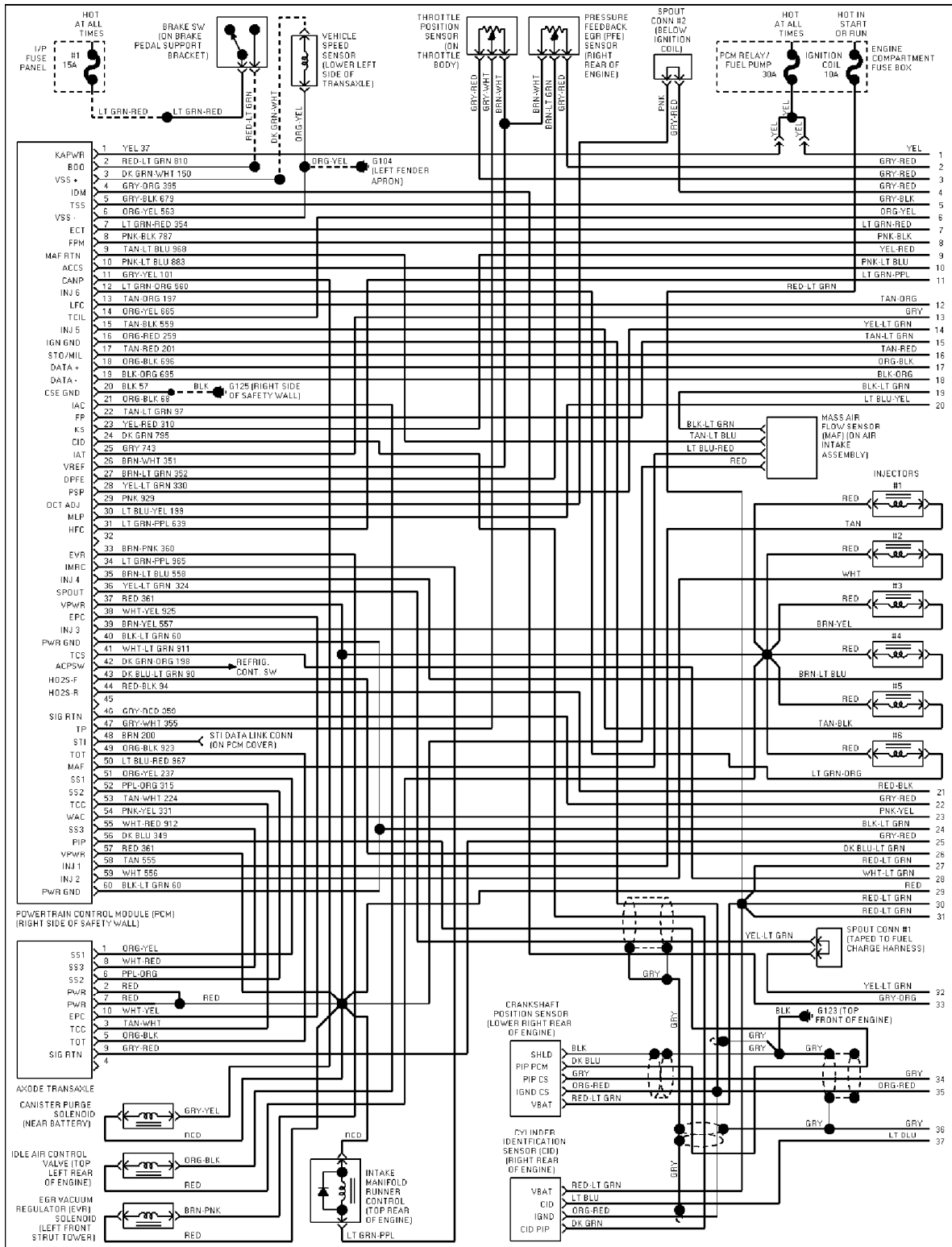

3.2L SHO, Engine Performance Circuits (1 of 2)

SYSTEM WIRING DIAGRAMS

Selected Block (p. 9)

1994 Ford Taurus

For <http://www.mitchell.narod.ru/>

Copyright © 1997 Mitchell International

Friday, March 02, 2001 09:01PM

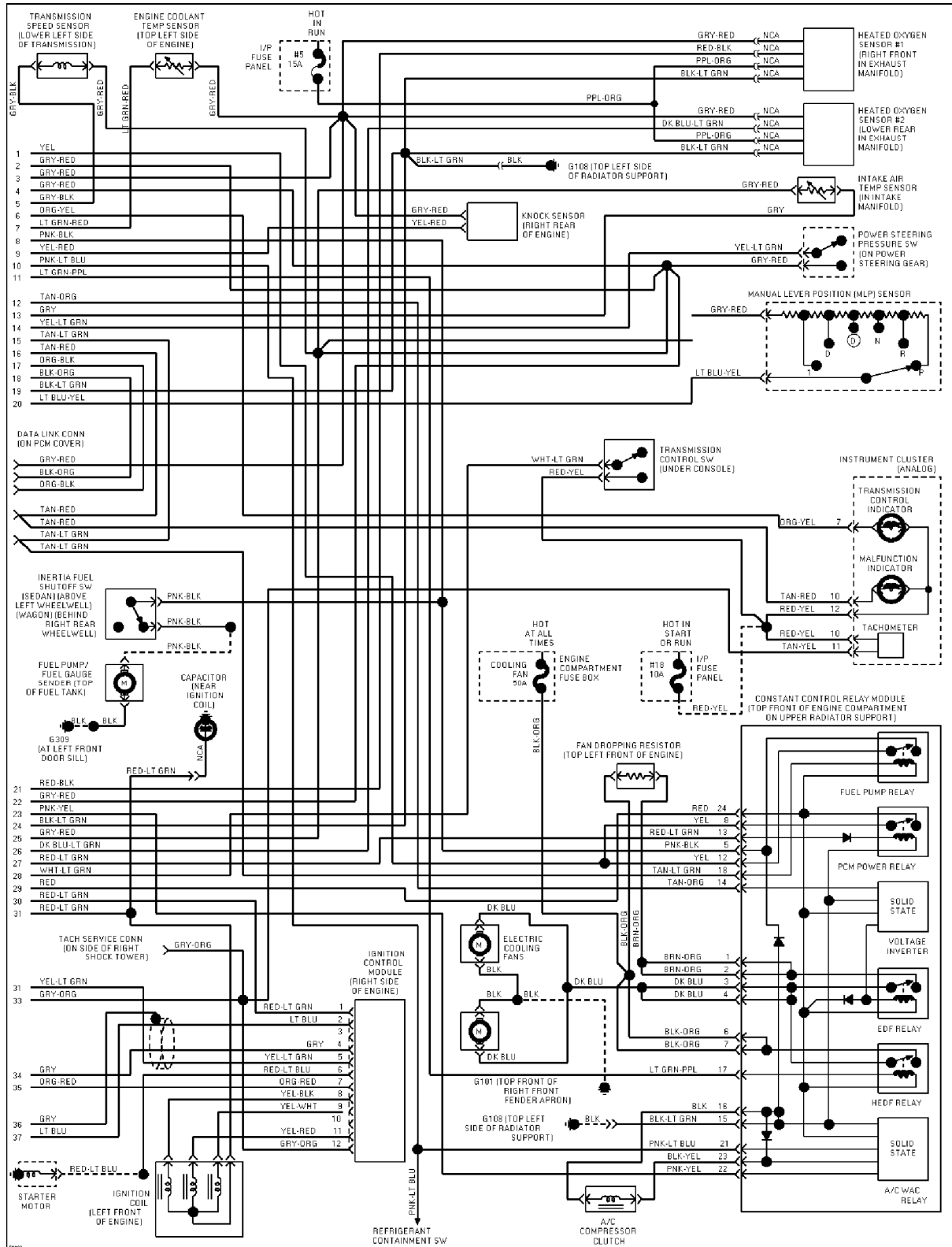

3.2L SHO, Engine Performance Circuits (2 of 2)

SYSTEM WIRING DIAGRAMS

Selected Block (p. 10)

1994 Ford Taurus

For <http://www.mitchell.narod.ru/>

Copyright © 1997 Mitchell International

Friday, March 02, 2001 09:01PM

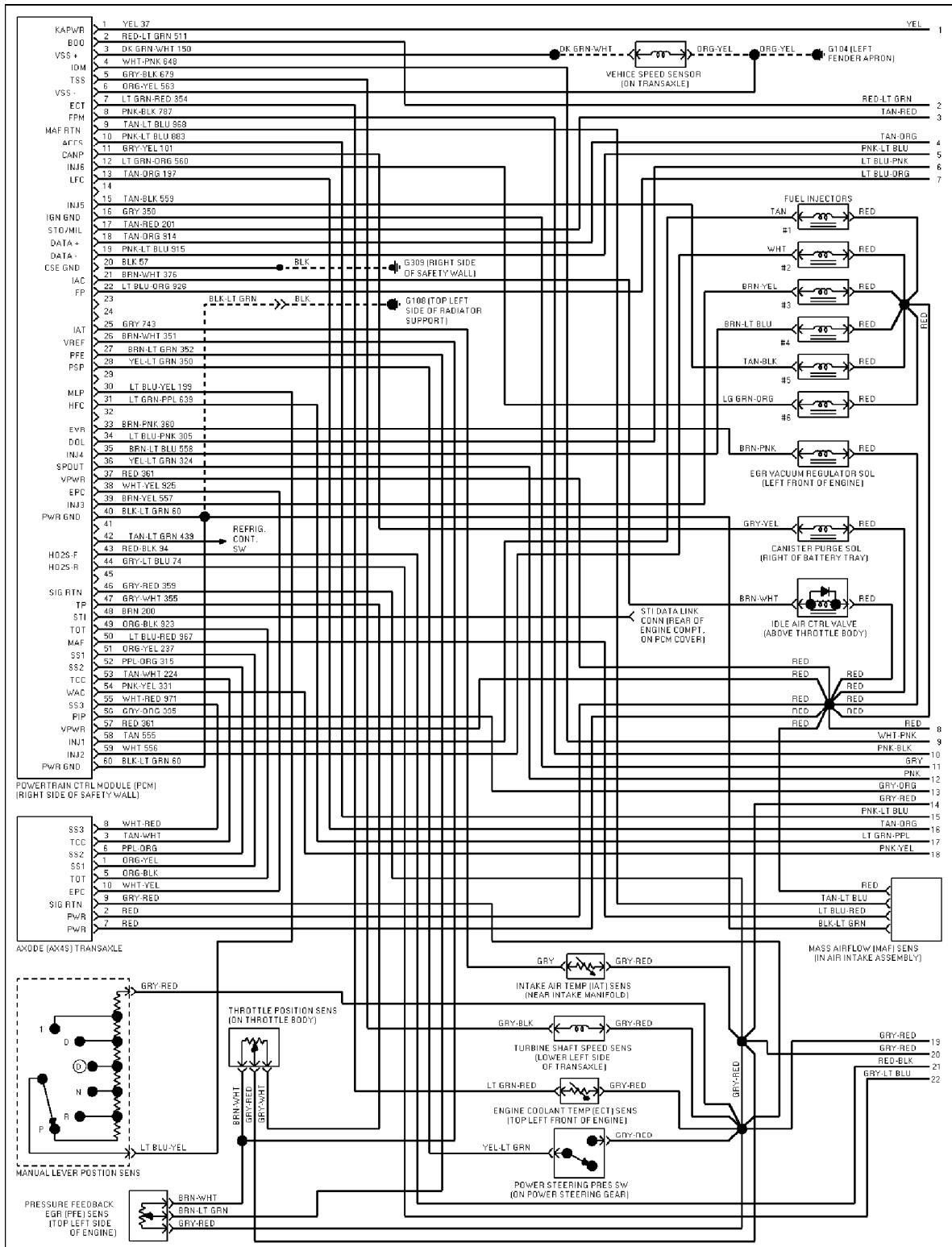

3.8L, Engine Performance Circuits (1 of 2)

SYSTEM WIRING DIAGRAMS

Selected Block (p. 11)

1994 Ford Taurus

For <http://www.mitchell.narod.ru/>

Copyright © 1997 Mitchell International

Friday, March 02, 2001 09:01PM

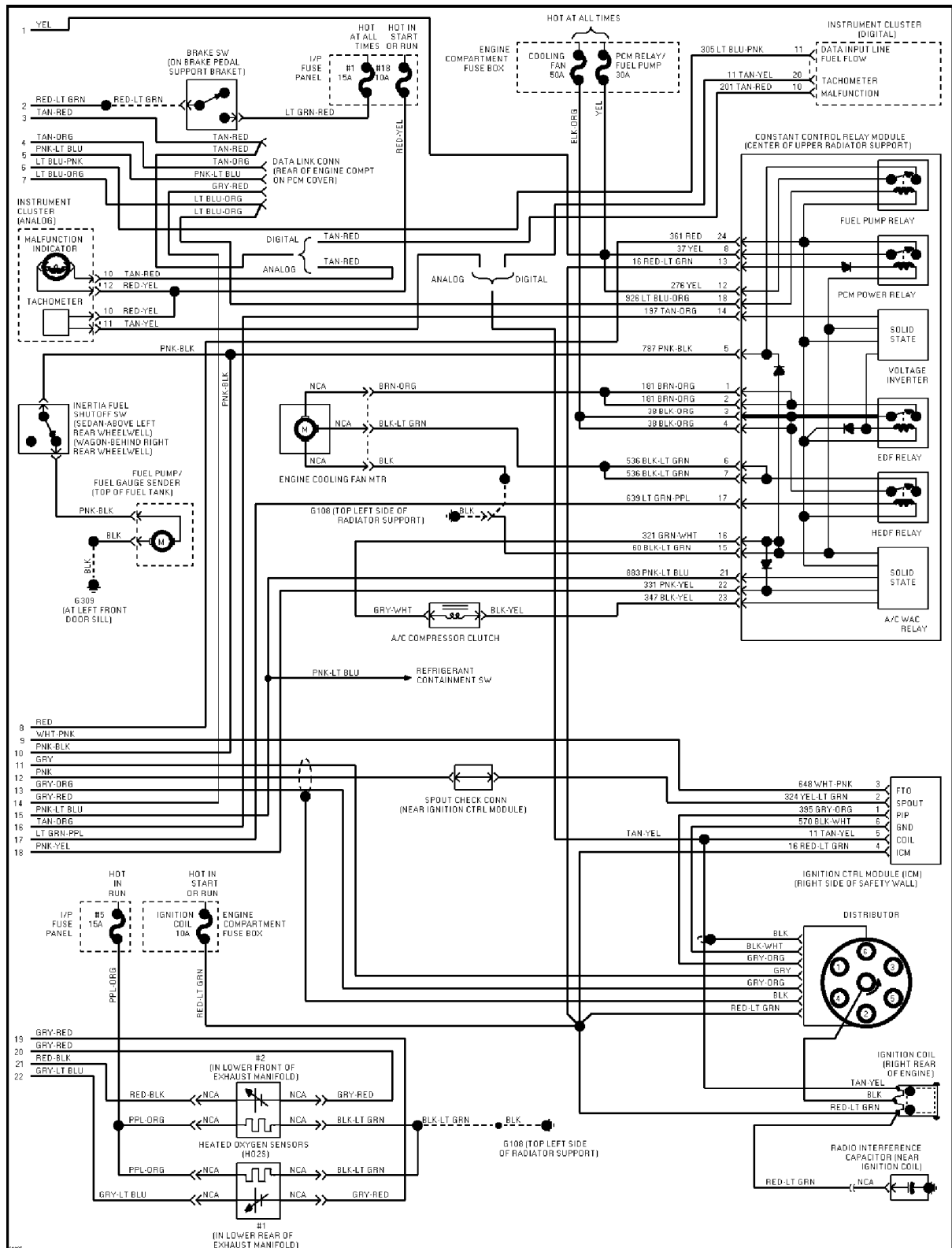

3.8L, Engine Performance Circuits (2 of 2)