

# SYSTEM WIRING DIAGRAMS

## Selected Block

1996 Ford Taurus

For <http://www.mitchell.narod.ru/>

Copyright © 1997 Mitchell International

Friday, March 02, 2001 09:11PM

### BODY COMPUTER

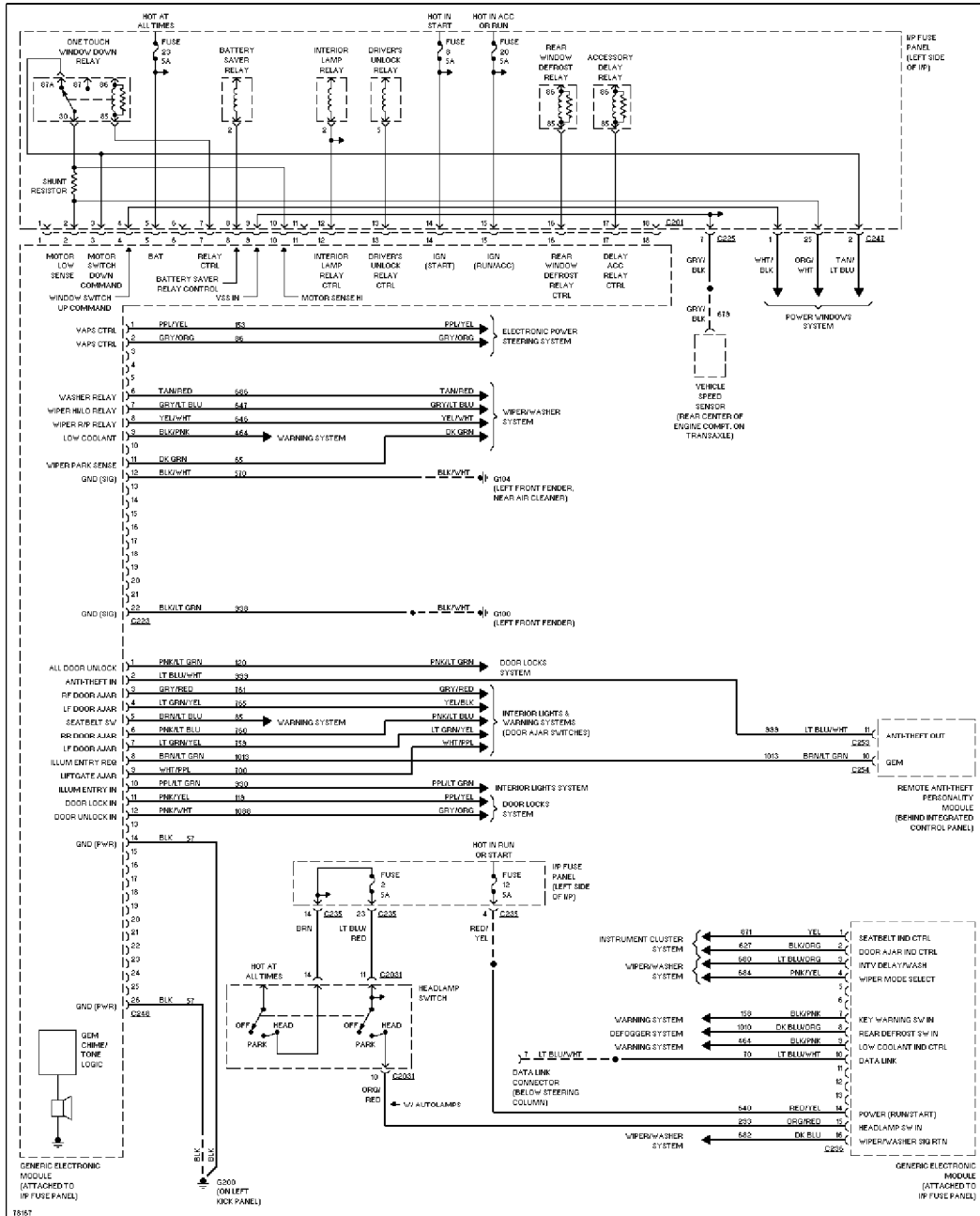

Body Computer Circuits

### COMPUTER DATA LINES

# SYSTEM WIRING DIAGRAMS

## Selected Block (p. 2)

1996 Ford Taurus

For <http://www.mitchell.narod.ru/>

Copyright © 1997 Mitchell International

Friday, March 02, 2001 09:11PM

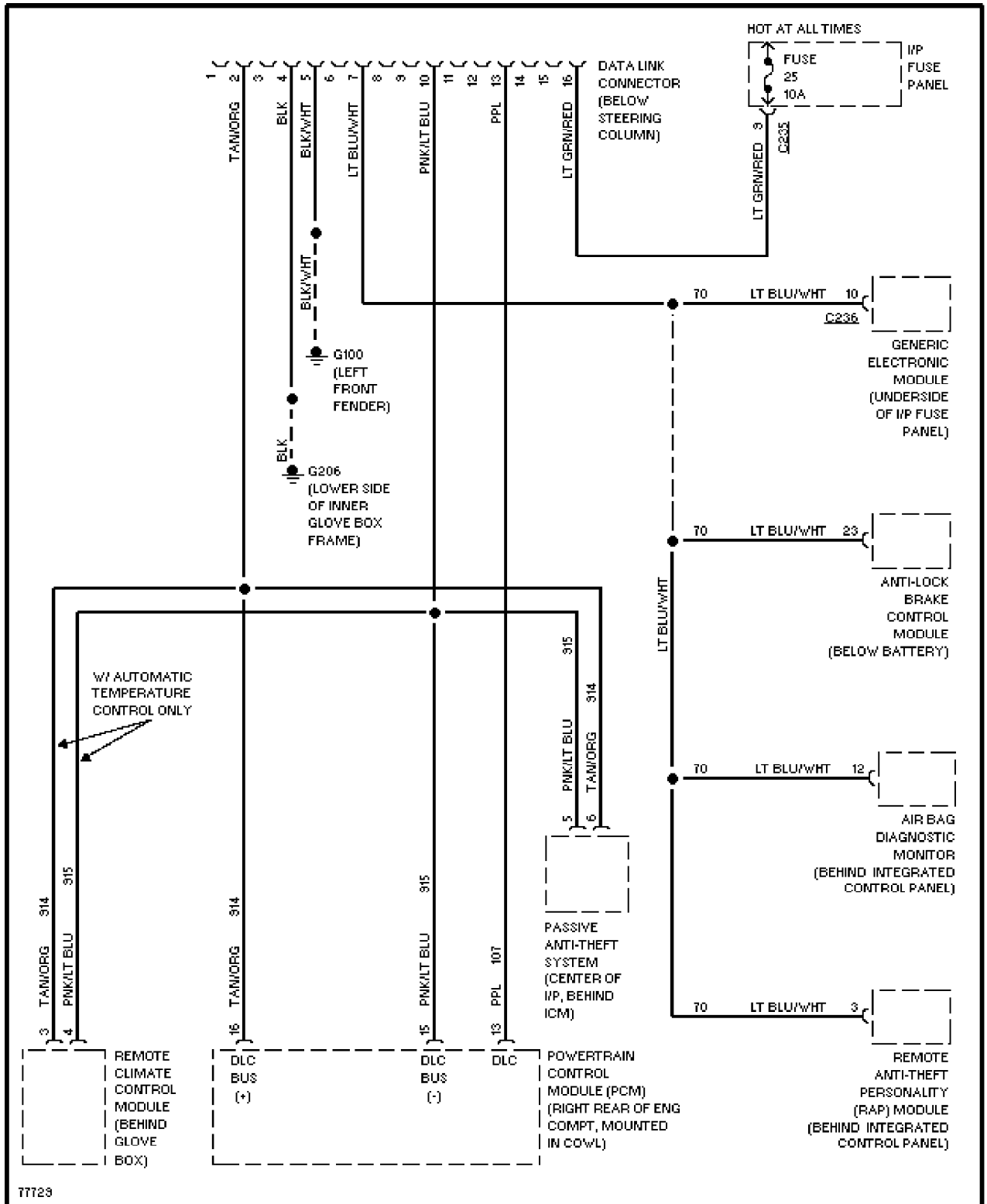

# SYSTEM WIRING DIAGRAMS

## Selected Block (p. 3)

1996 Ford Taurus

For <http://www.mitchell.narod.ru/>

Copyright © 1997 Mitchell International

Friday, March 02, 2001 09:11PM

### COOLING FAN

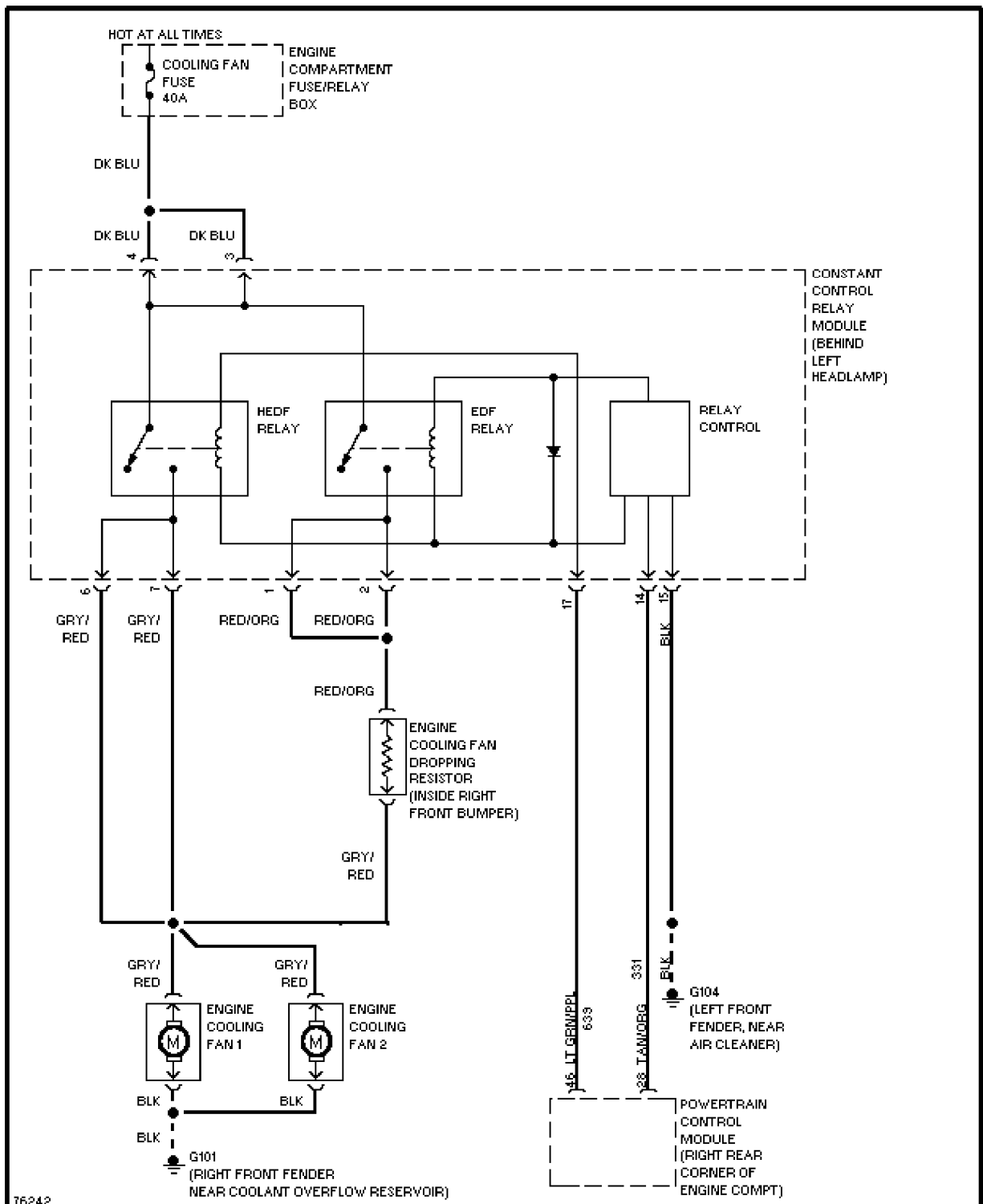

Cooling Fan Circuit

# SYSTEM WIRING DIAGRAMS

## Selected Block (p. 4)

1996 Ford Taurus

For <http://www.mitchell.narod.ru/>

Copyright © 1997 Mitchell International

Friday, March 02, 2001 09:11PM

### CRUISE CONTROL

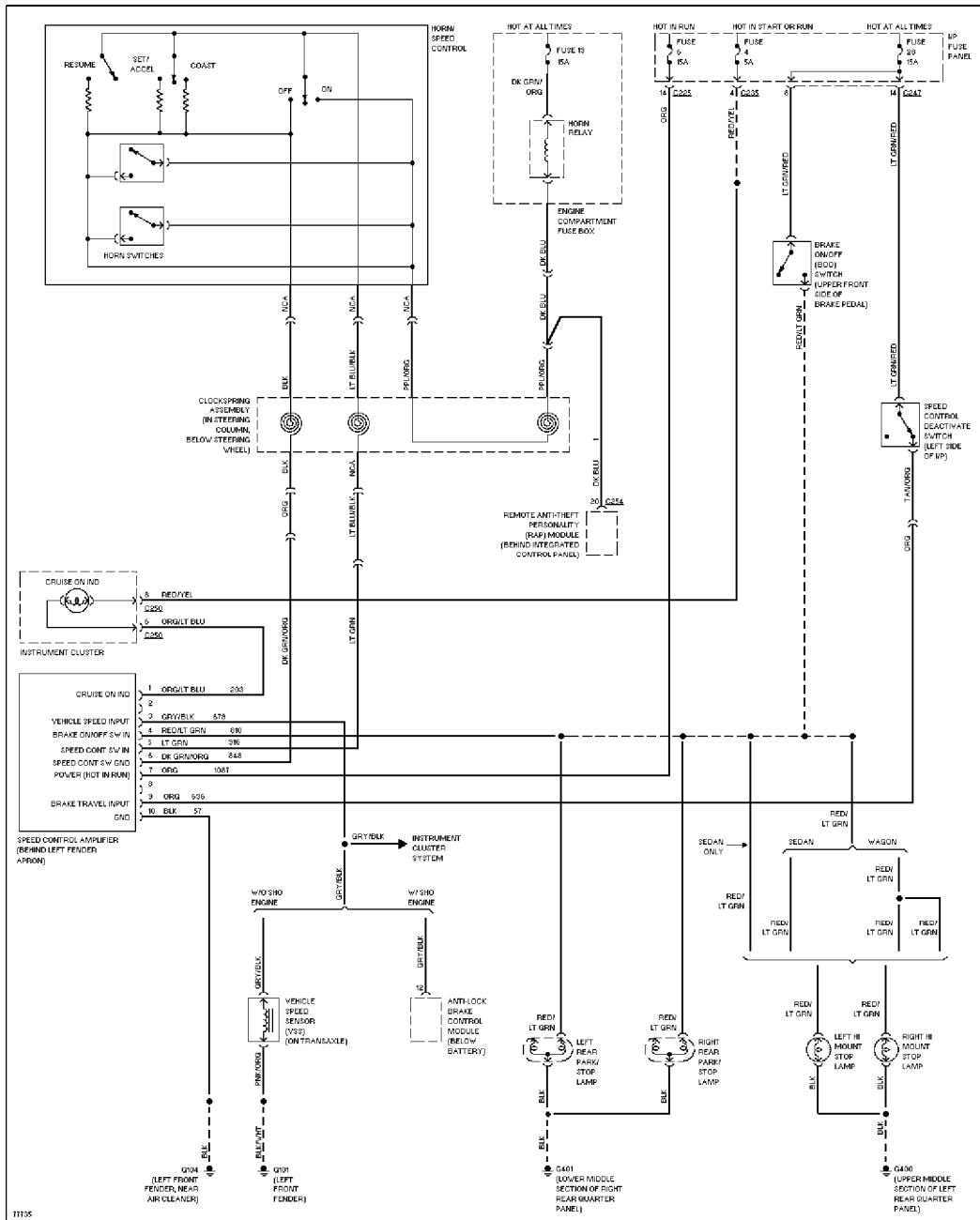

Cruise Control Circuit